

Flanges

Committed to offering the perfect match for every hose or tube application, our Hydraulics offers flanges that accommodate every configuration and substrate. All flanges meet or exceed all industry standards and specifications, and only we can provide the most efficient and appropriate flange for every hose or tube product.

Tubes

The tube programme from Parker Hannifin gives all possibilities for usage in hydraulic applications. Tubes for fitting- and flange-systems, tubes for mobile and stationary systems. Different dimensions, carbon- and stainless-steel tubes as well as different surfaces are available. Parker tubes are designed for the special requirements in several markets. Continuous tests in laboratories and on test benches ensure the high quality level of the material. Certifications from independent institutes such as ABS, LR or DNV confirm the adherence to high standards. This opens into reliability and longevity of the hydraulic application.

Tube Clamps

Tube clamps are designed for restraining tube, pipe and hose assemblies against unwanted and potentially harmful effects of mechanical shock and vibration forces that are common in fluid power systems. The clamping system is the most commonly overlooked aspect of fluid power system design. Failure to properly restrain the fluid conductors can result in leakage, downtime and system malfunction, as well as significantly reduce the life of tube, pipe and hose assemblies.

Valves

Our Hydraulics supplies a comprehensive line of ball valves that control flow direction and provide shut off, with port configurations that support a diverse range of system requirements. Available in stainless steel, PTFE, steel and brass, these ball valves offer a variety of seat and seal materials.

SAE Flange Clamps



5115 / 5116
SAE Split flange halves
P. 9

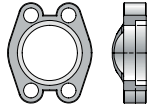

5117 / 5118
SAE Flange clamps
P. 10



5119 / 5120
SAE Flange clamps (tapped holes)
P. 11

SAE Flange adapters

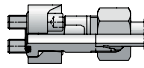

GFS
SAE Straight flange adapter
P. 12 / 13

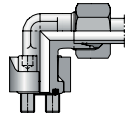

WFS
SAE 90° Elbow flange adapter
P. 14 / 15

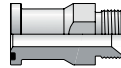

GFS-G
SAE Straight flange adapter
P. 16

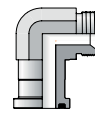

WFS-G
SAE 90° Elbow flange adapter
P. 17

Butt weld end

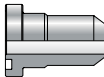

5125 / 5126
SAE Flange adapter O-ring
P. 18 / 19

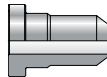

5127 / 5128
SAE Flange adapter Flat
P. 18 / 19

BSP Female thread

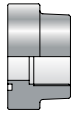

5150 / 5151
SAE Flange with BSP thread
P. 20



5152 / 5153
SAE Flange with BSP thread-Flat
P. 21

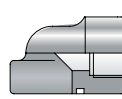

5102 / 5103
SAE 90° Flange with BSP thread
P. 22

NPT Female thread

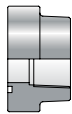

5150N / 5151N
SAE Flange with NPT thread
P. 23



5152N / 5153N
SAE Flange with NPT thread
P. 24

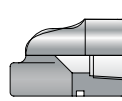

5102N / 5103N
SAE 90° Flange with NPT thread
P. 25

Butt weld end

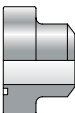

5142 / 5143
SAE Flange (butt weld)
P. 26



5144 / 5145
SAE Flange counter (butt weld)
P. 27

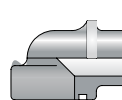

5167 / 5168
SAE 90° Flange (butt weld)
P. 28

Socket weld end

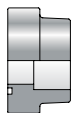

5138 / 5139
SAE Flange socket weld
P. 29

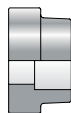

5140 / 5141
SAE Flange socket weld counter
P. 30

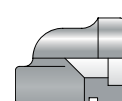

5106 / 5107
SAE 90° Flange socket weld
P. 31

INDEX

SAE Flange accessories

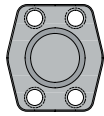

5146 / 5147
SAE Closed flange
P. 32

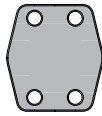

5148 / 5149
SAE Closed counter flange
P. 33

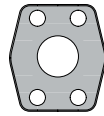

5064 / 5065
SAE Flange connector plate
P. 34

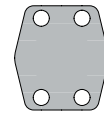

5062 / 5063
SAE Flange locking plate
P. 35



5060 / 5061
Flange head plug flat
P. 36

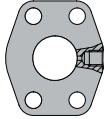

5112 / 5113
SAE 4 bolt flange with test point port
P. 37

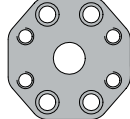

PRF
SAE Straight reducing flange adapter
P. 38



Screws and O-rings
according ISO 6162-1 and -2
P. 7

Gear pump flanges

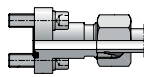

BFG
Gear pump flange straight
P. 39

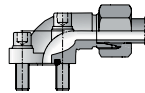

BFW
Gear pump flange 90° elbow
P. 40

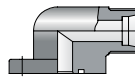

BFW3
Gear pump flange 90° 3 holes
P. 41

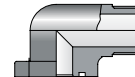

BFW-G
Gear pump flange 90°
P. 42

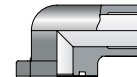

BFW-GI
Gear pump flange 90°
P. 43

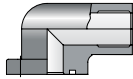

BFW3-G
Gear pump flange 90°
3 holes
P. 44

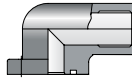

PWDS-G
Gear pump flange 90°
4 holes – aluminium
P. 45

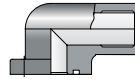

PWDA
Gear pump flange 90°
3 holes – aluminium
P. 46

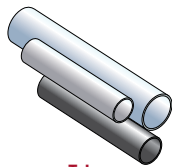

Tubes
Steel, CF and Stainless Steel
P. 48 / 64

Tubes

Tube Clamps

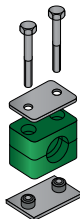

Tube clamps series A
(Light construction series)
P. 70 / 75

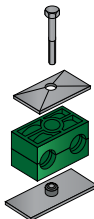

Tube clamps series B
(Twin-tube clamps)
P. 76 / 79

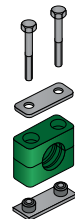

Tube clamps series C
(Heavy series)
P. 80 / 84



Tube clamps series O
P. 85

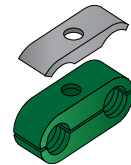

Double-Tube clamps series O
P. 86

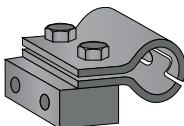

HSRS
Hydraulic steel-clamps
P. 87 / 88

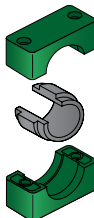

Tube Clamps with Elastomer Inlay
P. 89

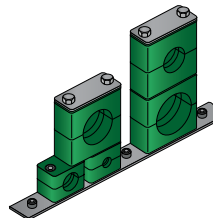

Tube clamps series 2+5
(Light construction series)
P. 90 / 91

INZEN

2-way ball valve with threaded connection (low pressure)

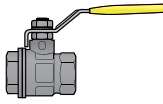

9011-..
BSPP brass ball valve
P. 92

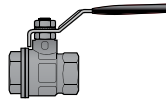

9011-..Z
BSPP brass ball valve heavy
P. 92



9012-..
Gate valve with cast handwheel
P. 93

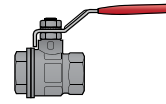

9013-..
BSPP brass ball valve
P. 93

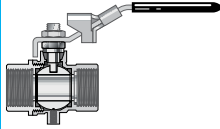

BVG4PLOCK
BSSP, Vented & Locking Handle
P. 95



MBVG
BSSP short threads - Compact
P. 97

2-way ball valve with threaded connection

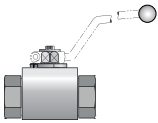

9014-..
2-way BSPP ball valve
P. 98

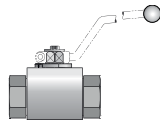

9015-..
2-way NPT ball valve
P. 98

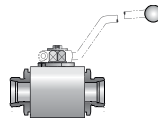

9016-..
2-way Metric ball valve (L-serie)
P. 99

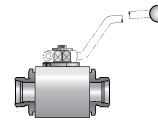

9017-..
2-way Metric ball valve (S-serie)
P. 99

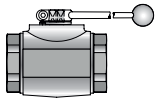

9018-..
2-way BSPP ball valve
P. 100

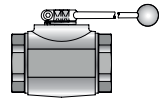

9018-..NPT
2-way NPT ball valve
P. 100

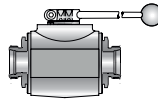

9019-..
2-way Metric ball valve (L-serie)
P. 101

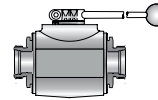

9019-..
2-way Metric ball valve (S-serie)
P. 101

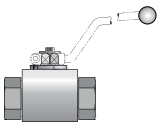

9028-..
2-way NPT ball valve (800 bar)
P. 102

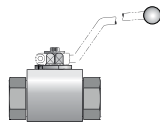

9029-..
2-way Metric ball valve (800 bar)
P. 102

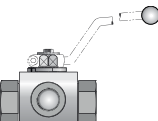

9001-..
3-way BSPP ball valve
P. 103

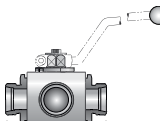

9002-..
3-way Metric ball valve (L-serie)
P. 104

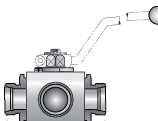

9003-..
3-way Metric ball valve (S-serie)
P. 105

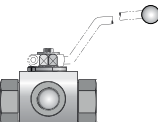

9004-..
3-way BSPP ball valve
P. 103

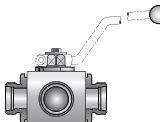

9005-..
3-way Metric ball valve (L-serie)
P. 104

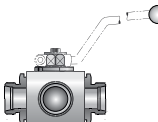

9006-..
3-way Metric ball valve (S-serie)
P. 105



3/2-way selector ball valves with threaded connections L-bore

3/2-way selector ball valves with threaded connections T-bore



**3-way valves
with threaded
connections
L-bore**

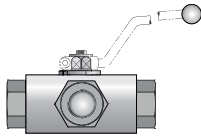

9030-..
BSPP 3-way ball valve
P. 106

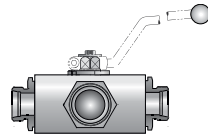

9031-..
Metric 3-way ball valve (L-series)
P. 108

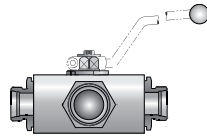

9032-..
Metric 3-way ball valve (S-series)
P. 110

**3-way valves
with threaded
connections
T-bore**

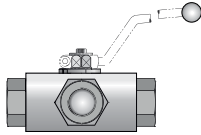

9033-..
BSPP 3-way ball valve
P. 107

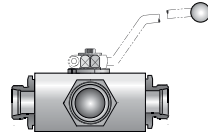

9034-..
Metric 3-way ball valve (L-series)
P. 109

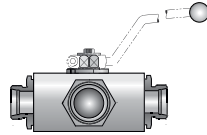

9035-..
Metric 3-way ball valve (S-series)
P. 111

**4-way valves
with threaded
connections**

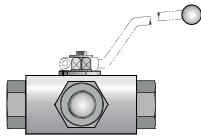

9043-..
BSPP 4-way ball valve (T-bore)
P. 112

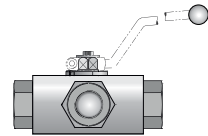

9046-..
BSPP 4-way ball valve (X-bore)
P. 115

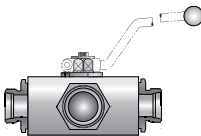

9044-..
Metric 4-way ball valve (T-bore)
P. 113

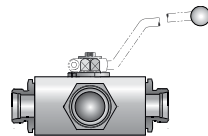

9045-..
Metric 4-way ball valve (T-bore)
P. 114

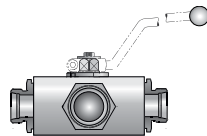

9047-..
Metric 4-way ball valve (X-bore)
P. 116

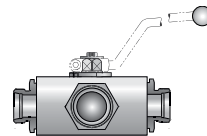

9048-..
Metric 4-way ball valve (X-bore)
P. 117

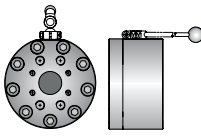

9020 / 9021-..
Ball valve with SAE connection
P. 118 / 119

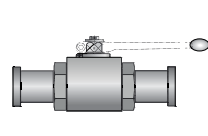

9022 / 9023-..
Ball valve with SAE split flange
P. 120 / 121

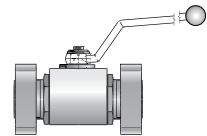

9024 / 9025-..
Ball valve with SAE adapter
P. 122 / 123

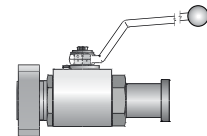

9026 / 9027-..
Ball valve with SAE adapter
P. 124 / 125

Needle valves

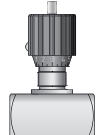

9049-..
Flow control valve
P. 130

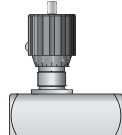

9050-..
Flow control check valve
P. 131

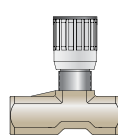

SCV-....
Speed control check valve
P. 132

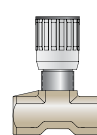

UC-....
Speed control valve
P. 133

Check valves



UC-....
Inline Check Valves
P. 128



600013-..-..
Check valve for piping-system
P. 129

INDEX

Technical data

Flange screws

SAE Flanges according to ISO 6162-1 and -2 (SAE J518)

- metric screws according to ISO4762-10.9 (DIN 912-10.9) or higher quality
- UNC screws according to ANSI/ASME B 18.3

Gear pump flanges

- metric screws according to DIN 912-8.8 (ISO 4762-8.8)

Used Sealing

Materials

Flanges according **SAE J518 (ISO 6162-1 and -2), ISO 6164, Cetop** and all **gear pump flanges** in this catalogue are sealed with an O-ring. The seals of our flanges are out of the following materials:

- NBR (e.g. perbunan) 90 shore A durometer is our standard seal material for hydraulic **steel** flange applications.
- FKM 85 or 90 shore A durometer is our standard seal material for hydraulic **stainless steel** flange applications.

Perbunan = registered trademark of Bayer

Pressure ratings

The maximum recommended working pressure is indicated for each article. Before using a part, please take notice of the pressure ratings. All pressure indications are based on a working temperature from -20° celsius up to $+100^{\circ}$ celsius (resp. ambient temperature from -40° celsius up to $+120^{\circ}$ celsius). Outside of this temperature range the physical properties of the material is affected and the maximum recommended working pressure is reduced. The indicated working pressures refer only to the flange itself. For the tubes, fittings and connections the pressure ratings of the specific manufacturer must also be taken into account.

Materials

SAE flanges according to ISO 6162-1 and -2 (SAE 518)

Flange clamps, flange adapter and forged 4 bolt flanges are made of the material ST 52.3 or compatible for **steel** construction. For **stainless steel** constructions we are using for flange clamps, flange adapters and 4 bolt forged flanges the material 1.4401 (316) or compatible. For special applications it is also possible to get the flange adapters made from the material 1.4571 (316Ti).

Gear pump flanges

Steel forged construction: GTW40 or compatible

Steel construction: ST52.3, 11SMnPb30 or compatible

Surface protection

Surface possibilities are:

1. Oil dipped
2. Cr(VI)-free surface protection type CF

Order codes screws and O-rings

Screws for flanges

according ISO 6162-1 and -2 (SAE J518)

Nominal flange size			Screws for flange halves				Screws for full flanges			
Series	ISO	SAE	metr. Order code	Size	UNC Order code	Size	metr. Order code	Size	UNC Order code	Size
3000 PSI	13	1/2	090700	M08 x 30	090701	5/16 x 1 1/4	090700	M08 x 30	090701	5/16 x 1 1/4
	19	3/4	090730	M10 x 35	090731	3/8 x 1 1/2	090730	M10 x 35	090731	3/8 x 1 1/2
	25	1	090730	M10 x 35	090731	3/8 x 1 1/2	090730	M10 x 35	090731	3/8 x 1 1/2
	32	1 1/4	090730	M10 x 35	090771	7/16 x 1 1/2	090730	M10 x 35	090771	7/16 x 1 1/2
	38	1 1/2	090750	M12 x 35	090791	1/2 x 1 3/4	090750	M12 x 35	090791	1/2 x 1 3/4
	51	2	090750	M12 x 35	090791	1/2 x 1 3/4	090750	M12 x 35	090791	1/2 x 1 3/4
	64	2 1/2	090760	M12 x 40	090791	1/2 x 1 3/4	090760	M12 x 40	090791	1/2 x 1 3/4
	76	3	090800	M16 x 50	090801	5/8 x 2	090800	M16 x 50	090801	5/8 x 2
	89	3 1/2	090800	M16 x 50	090801	5/8 x 2	090800	M16 x 50	090801	5/8 x 2
	102	4	090800	M16 x 50	090801	5/8 x 2	090800	M16 x 50	090801	5/8 x 2
102	4 1/2	090800	M16 x 50	090801	5/8 x 2	090800	M16 x 50	090801	5/8 x 2	
Serie	ISO	SAE	metr. Order code	Size	UNC Order code	Size	metr. Order code	Size	UNC Order code	Size
6000 PSI	13	1/2	090700	M08 x 30	090701	5/16 x 1 1/4	090700	M08 x 30	090701	5/16 x 1 1/4
	19	3/4	090730	M10 x 35	090731	3/8 x 1 1/2	090740	M10 x 40	090731	3/8 x 1 1/2
	25	1	090770	M12 x 45	090791	1/2 x 1 1/2	090770	M12 x 45	090771	7/16 x 1 1/2
	32	1 1/4	090790	M14 x 50	090791	1/2 x 1 3/4	090790	M14 x 50	090791	1/2 x 1 3/4
	38	1 1/2	090810	M16 x 55	090801	5/8 x 2	090810	M16 x 55	090801	5/8 x 2
	51	2	090820	M20 x 65	090821	3/4 x 2 1/2	090820	M20 x 65	090821	3/4 x 2 1/2

Tubes

Tube clamps

Valves

O-rings for flanges

SAE J518

ISO (DN)	SAE (Inch)	O-ring		O-ring size
		NBR Order code	FKM Order code	
13	1/2	5130-37	5130-37VIT	18.64×3.53
19	3/4	5130-51	5130-51VIT	24.99×3.53
25	1	5130-61	5130-61VIT	32.92×3.53
32	1 1/4	5130-67	5130-67VIT	37.70×3.53
38	1 1/2	5130-73	5130-73VIT	47.23×3.53
51	2	5130-75	5130-75VIT	56.75×3.53
64	2 1/2	5130-79	5130-79VIT	69.44×3.53
76	3	5130-81	5130-81VIT	85.32×3.53
89	3 1/2	5130-83	5130-83VIT	98.02×3.53
102	4	5130-85	5130-85VIT	110.72×3.53
127	5	5130-87	5130-87VIT	136.12×3.53

Notes



5115 / 5116 - SAE Split flange halves

ISO 6162-1/-2

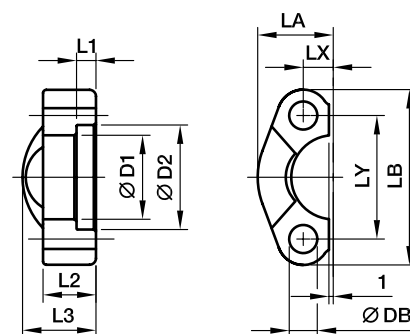

3000 PSI Series

Nom. flange size SAE (in.)	ISO (DN)	D1	D2	L1	L2	L3	LA	LB	LX	LY	DB	Weight (steel) kg/piece	Order code*	PN (bar)	
														CF	SS
1/2	13	24.3	31.0	6.2	13	19	23.0	54.0	8.7	38.1	9.0	0.07	5115-08	345	345
3/4	19	32.2	38.9	6.2	14	22	25.9	65.0	11.1	47.6	11.0	0.09	5115-12	345	345
1	25	38.5	45.2	7.5	16	24	29.2	69.9	13.1	52.4	11.0	0.11	5115-16	345	345
1 1/4	32	43.7	51.6	7.5	16	22	36.3	79.4	15.1	58.7	12.5	0.15	5115-20	276	276
1 1/2	38	50.8	61.1	7.5	16	25	41.1	93.8	17.9	69.9	13.0	0.23	5115-24	207	207
2	51	62.8	72.3	9.0	16	26	48.2	101.6	21.4	77.8	14.5	0.25	5115-32	207	207
2 1/2	64	74.9	84.9	9.0	19	38	54.1	114.3	25.4	88.9	13.0	0.37	5115-40	172	172
3	76	90.9	102.4	9.0	22	41	65.3	135.0	31.0	106.4	17.0	0.65	5115-48	138	138
3 1/2	89	102.4	115.0	10.7	22	28	68.6	152.4	34.9	120.7	17.0	0.75	5115-56	34	34
4	102	115.1	127.8	10.7	25	35	74.9	162.0	38.9	130.2	17.0	0.84	5115-64	34	34
5	127	140.5	153.2	10.7	28	41	89.4	184.2	46.0	152.4	17.0	1.25	5115-80	34	34

6000 PSI Series

1/2	13	24.6	32.5	7.2	16	22	24.0	56.4	9.1	40.5	9.0	0.08	5116-08	420	420
3/4	19	32.5	42.0	8.3	19	28	30.0	72.0	11.9	50.8	11.0	0.18	5116-12	420	420
1	25	38.8	48.4	9.0	24	33	34.8	81.0	13.9	57.2	13.0	0.27	5116-12	420	420
1 1/4	32	44.5	54.8	9.8	27	38	38.6	95.3	15.9	66.6	15.0	0.27	5116-20	420	420
1 1/2	38	51.6	64.3	12.1	30	43	47.5	112.8	18.3	79.3	17.0	0.40	5116-24	420	420
2	51	67.6	80.2	12.1	37	52	56.9	133.4	22.2	96.8	22.0	0.40	5116-32	420	420
2 1/2	64	90.0	108.0	20.0	45	45	75.1	180.0	29.4	123.8	25.0	0.68	5116-40	420	420
3	76	115.0	132.5	25.0	55	55	99.1	215.0	35.7	152.4	31.5	1.05	5116-48	420	420

*Please add suffix **RVS** after partnumber if stainless steel is required.

5117 / 5118 - SAE Flange clamps

ISO 6162-1/-2

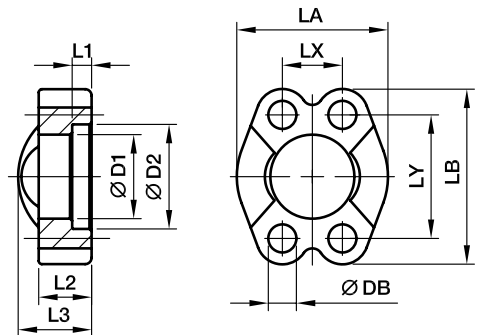

3000 PSI Series

Nom. flange size SAE (in.)	ISO (DN)	D1	D2	L1	L2	L3	LA	LB	LX	LY	DB	Weight (steel) kg/piece	Order code*	PN (bar)	
														CF	SS
1/2	13	24.3	31.0	6.2	13	19	46	54.0	17.5	38.1	8.8	0.15	5117-08	345	345
3/4	19	32.2	38.9	6.2	14	22	52	65.0	22.3	47.6	10.5	0.17	5117-12	345	345
1	25	38.5	45.2	7.5	16	24	59	69.9	26.2	52.4	10.5	0.22	5117-16	345	345
1 1/4	32	43.7	51.6	7.5	16	22	73	79.4	30.2	58.7	12.5	0.29	5117-20	276	276
1 1/2	38	50.8	61.1	7.5	16	25	83	93.8	35.8	69.9	13.5	0.45	5117-24	207	207
2	51	62.8	72.3	9.0	16	26	97	101.6	42.8	77.8	14.5	0.49	5117-32	207	207
2 1/2	64	74.9	84.9	9.0	19	38	109	114.3	50.8	88.9	13.5	0.74	5117-40	172	172
3	76	90.9	102.4	9.0	22	41	131	135.0	61.9	106.4	17.0	1.30	5117-48	138	138
3 1/2	89	102.4	115.0	10.7	22	28	140	152.4	69.9	120.7	17.0	1.50	5117-56	34	34
4	102	115.1	127.8	10.7	25	35	150	162.0	77.8	130.2	17.0	1.65	5117-64	34	34
5	127	140.5	153.2	10.7	28	41	180	184.2	92.1	152.4	17.0	2.50	5117-80	34	34

6000 PSI Series

1/2	13	24.6	32.5	7.2	16	22	48	56.4	18.2	40.5	8.8	0.16	5118-08	420	420
3/4	19	32.5	42.0	8.3	19	28	60	71.4	23.8	50.8	10.5	0.35	5118-12	420	420
1	25	38.8	48.4	9.0	24	33	70	81.0	27.8	57.2	13.0	0.53	5118-16	420	420
1 1/4	32	44.5	54.8	9.8	27	38	78	95.3	31.8	66.6	15.0	0.80	5118-20	420	420
1 1/2	38	51.6	64.3	12.1	30	43	96	112.8	36.5	79.3	17.0	1.35	5118-24	420	420
2	51	67.6	80.2	12.1	37	52	114	133.4	44.5	96.8	21.0	2.10	5118-32	420	420
2 1/2	64	90.0	108.9	20.5	45	45	150	180.0	58.7	123.8	25.0	4.10	5118-40	420	420
3	76	115.0	132.5	25.5	55	55	178	215.0	71.4	152.4	32.0	8.60	5118-48	420	420

*Please add suffix **RVS** after partnumber if stainless steel is required.

5119 / 5120 - SAE Flange clamps with metric tapped holes

ISO 6162-1/-2

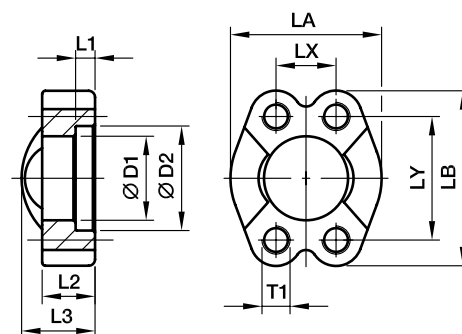

3000 PSI Series

Nom. flange size SAE (in.)	ISO (DN)	D1	D2	L1	L2	L3	LA	LB	LX	LY	T1	Weight (steel) kg/piece	Order code*	PN (bar)	
														CF	SS
1/2	13	24.3	31.0	6.2	13	20	46	54.0	17.5	38.1	M8	0.15	5119-08	345	345
3/4	19	32.1	38.9	6.2	14	22	52	65.0	22.3	47.6	M10	0.17	5119-12	345	345
1	25	38.5	45.2	7.5	16	24	59	69.9	26.2	52.4	M10	0.22	5119-16	345	345
1 1/4	32	43.7	51.6	7.5	16	22	73	79.4	30.2	58.7	M10	0.30	5119-20	276	276
1 1/2	38	50.8	61.1	7.5	16	25	83	93.8	35.7	69.9	M12	0.45	5119-24	207	207
2	51	62.8	72.3	9.0	16	26	97	101.6	42.9	77.8	M14	0.49	5119-32	207	207
2 1/2	64	74.9	84.9	9.0	19	38	109	114.3	50.8	88.9	M12	0.74	5119-40	172	172
3	76	90.9	102.4	9.0	22	41	131	135.0	61.9	106.4	M16	1.30	5119-48	138	138
3 1/2	89	102.4	115.0	10.7	23	28	140	152.4	69.9	120.7	M16	1.50	5119-56	34	34
4	102	115.1	127.8	10.7	25	35	150	162.0	77.8	130.2	M16	1.65	5119-64	34	34
5	127	140.5	153.2	10.7	28	41	180	184.2	92.1	152.4	M16	2.50	5119-80	34	34

6000 PSI Series

1/2	13	24.6	32.5	7.2	16	22	48	56.4	18.2	40.5	M8	0.16	5120-08	420	420
3/4	19	32.5	42.0	8.2	19	28	60	71.4	23.8	50.8	M10	0.35	5120-12	420	420
1	25	38.9	48.4	9.0	24	33	70	81.0	27.8	57.2	M12	0.53	5120-16	420	420
1 1/4	32	44.5	54.8	9.8	27	38	78	95.3	31.8	66.6	M14	0.80	5120-20	420	420
1 1/2	38	51.6	64.3	12.1	30	43	96	112.8	36.5	79.3	M16	1.35	5120-24	420	420
2	51	67.6	80.2	12.1	37	52	114	133.4	44.5	96.8	M20	2.10	5120-32	420	420
2 1/2	64	90.0	108.9	20.5	45	45	150	180.0	58.7	123.8	M24	4.10	5120-40	420	420
3	76	115.0	132.5	25.5	55	55	178	215.0	71.4	152.4	M30	8.60	5120-48	420	420

*Please add suffix **RVS** after partnumber if stainless steel is required.

Tubes

Tube clamps

Valves

GFS - SAE Straight flange adapter

SAE Flange / EO 24° cone end
(ISO 6162-1/-2)

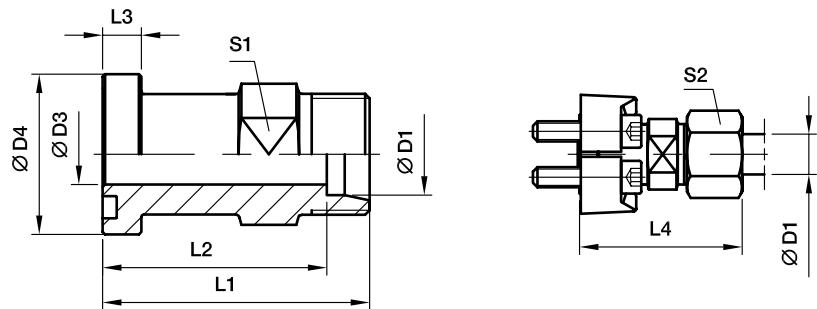

3000 PSI Series

Nom. flange size SAE (in.)	ISO (DN)	D1	D3	D4	L1	L2	L3	L4	S1	S2	Screws	Weight (steel) kg/piece	Order code*	PN (bar)	
														CF	71
1/2	13	15L	12.0	30.2	48.0	41.0	6.7	56.0	24	27	M 08×25	0.36	GFS32/15L	315	315
1/2	13	16S	12.0	30.2	50.0	41.5	6.7	60.0	24	30	M 08×25	0.40	GFS32/16S	350	350
1/2	13	18L	14.0	30.2	50.0	42.5	6.7	61.0	19	32	M 08×25	0.42	GFS32/18L	315	315
3/4	19	16S	12.0	38.1	55.0	46.5	6.7	64.5	27	30	M 10×30	0.52	GFS33/16S	350	350
3/4	19	18L	17.0	38.1	53.0	45.5	6.7	62.0	30	32	M 10×30	0.59	GFS33/18L	315	315
3/4	19	22L	19.0	38.1	53.0	45.5	6.7	62.0	30	36	M 10×30	0.59	GFS33/22L	160	160
3/4	19	28L	19.0	38.1	55.0	41.0	6.7	64.0	32	41	M 10×30	0.60	GFS33/28L	160	160
3/4	19	20S	17.0	38.1	57.0	46.5	6.7	68.0	30	36	M 10×30	0.65	GFS33/20S	350	350
3/4	19	25S	17.0	38.1	57.0	45.0	6.7	69.0	30	46	M 10×30	0.78	GFS33/25S	350	350
1	25	20S	25.0	44.5	60.0	48.5	8.0	71.0	32	36	M 10×30	0.70	GFS34/20S	350	350
1	25	28L	24.0	44.5	54.0	46.5	8.0	63.0	36	41	M 10×30	0.73	GFS34/28L	160	160
1	25	25S	20.0	44.5	58.0	46.5	8.0	60.0	36	46	M 10×30	0.84	GFS34/25S	350	350
1	25	30S	24.0	44.5	63.0	49.5	8.0	76.0	36	50	M 10×30	0.94	GFS34/30S	250	250
1	25	42L	24.0	44.5	76.0	65.0	8.0	87.5	41	60	M 10×30	0.95	GFS34/42L	160	160
1 1/4	32	35L	32.0	50.8	58.0	47.5	8.0	69.0	41	50	M 10×35	0.96	GFS35/35L/10	160	160
1 1/4	32	25S	27.0	50.8	60.0	48.0	8.0	72.0	41	46	M 10×35	1.11	GFS35/25S/10	200	200
1 1/4	32	30S	28.5	50.8	62.0	48.5	8.0	75.0	41	50	M 10×35	1.13	GFS35/30S/10	200	200
1 1/4	32	38S	28.0	50.8	66.0	50.0	8.0	81.0	46	60	M 10×35	1.36	GFS35/38S/10	200	200
1 1/4	32	28L	23.0	50.8	60.0	52.5	8.0	67.0	36	41	M 12×40	1.12	GFS35/28L	160	160
1 1/4	32	35L	32.0	50.8	58.0	47.5	8.0	69.0	41	50	M 12×40	1.02	GFS35/35L	160	160
1 1/4	32	25S	27.0	50.8	60.0	48.0	8.0	72.0	41	46	M 12×40	1.17	GFS35/25S	200	200
1 1/4	32	30S	28.5	50.8	62.0	48.5	8.0	75.0	41	50	M 12×40	1.20	GFS35/30S	200	200
1 1/4	32	38S	28.0	50.8	66.0	50.0	8.0	81.0	46	60	M 12×40	1.41	GFS35/38S	200	200
1 1/2	38	35L	30.0	60.3	65.0	54.5	8.0	76.0	46	50	M 12×35	1.20	GFS36/35L	160	160
1 1/2	38	42L	36.0	60.3	64.0	53.0	8.0	76.0	46	60	M 12×35	1.36	GFS36/42L	160	160
1 1/2	38	38S	32.0	60.3	70.0	54.0	8.0	85.0	46	60	M 12×35	1.63	GFS36/38S	200	200

*Please add suffix 71 after partnumber if stainless steel is required.

GFS - SAE Straight flange adapter

SAE Flange / EO 24° cone end
(ISO 6162-1/-2)

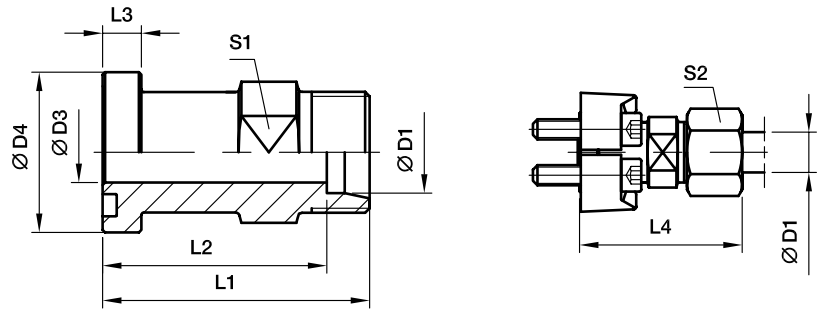

6000 PSI Series

Nom. flange size		D1	D3	D4	L1	L2	L3	L4	S1	S2	Screws	Weight (steel) kg/piece	Order code*	PN (bar)	
SAE (in.)	ISO (DN)													CF	71
1/2	13	12S	8	31.8	50.0	42.5	7.7	57.5	19	24	M 08×30	0.35	GFS62/12S	420	420
1/2	13	14S	10	31.8	50.0	42.0	7.7	59.5	19	27	M 08×30	0.39	GFS62/14S	420	420
1/2	13	16S	12	31.8	53.0	44.5	7.7	62.5	24	30	M 08×30	0.47	GFS62/16S	420	420
3/4	19	16S	17	41.3	59.0	50.5	8.7	68.5	30	30	M 10×35	0.79	GFS63/16S	420	420
3/4	19	20S	17	41.3	61.0	50.5	8.7	72.0	30	36	M 10×35	0.86	GFS63/20S	420	400
3/4	19	25S	17	41.3	63.0	51.0	8.7	75.0	30	46	M 10×35	0.97	GFS63/25S	420	400
3/4	19	30S	18	41.3	76.0	62.0	8.7	89.0	30	50	M 10×35	1.15	GFS63/30S	420	400
3/4	19	38S	18	41.3	85.0	69.0	8.7	99.5	41	60	M 10×35	1.15	GFS63/38S	315	315
1	25	20S	16	47.6	75.0	64.5	9.5	88.0	36	36	M 12×45	0.97	GFS64/20S	420	400
1	25	25S	20	47.6	72.0	60.0	9.5	84.0	36	46	M 12×45	1.42	GFS64/25S	420	400
1	25	30S	24	47.6	74.0	62.0	9.5	87.0	36	50	M 12×45	1.40	GFS64/30S	420	400
1	25	38S	24	47.6	84.5	68.0	9.5	99.0	46	60	M 12×45	1.40	GFS64/38S	315	315
1 1/4	32	25S	20	54.0	80.0	68.0	10.2	92.0	41	46	M 14×50	1.85	GFS65/25S	420	400
1 1/4	32	30S	30	54.0	79.0	65.5	10.2	92.0	41	50	M 12×45	1.95	GFS65/30S/12	420	400
1 1/4	32	38S	30	54.0	83.0	67.0	10.2	97.5	46	60	M 12×45	2.16	GFS65/38S/12	315	315
1 1/4	32	30S	30	54.0	79.0	65.5	10.2	92.0	41	50	M 14×50	1.90	GFS65/30S	420	400
1 1/4	32	38S	30	54.0	83.0	67.0	10.2	97.5	46	60	M 14×50	2.10	GFS65/38S	315	315
1 1/2	38	30S	30	63.5	90.0	74.0	12.5	103.0	46	50	M 16×55	2.10	GFS66/30S	420	400
1 1/2	38	38S	30	63.5	89.0	73.0	12.5	103.5	46	60	M 16×55	3.06	GFS66/38S	315	315

*Please add suffix **71** after partnumber if stainless steel is required.

WFS - SAE 90° Elbow flange adapter

SAE Flange / EO 24° cone end
(ISO 6162-1/-2)

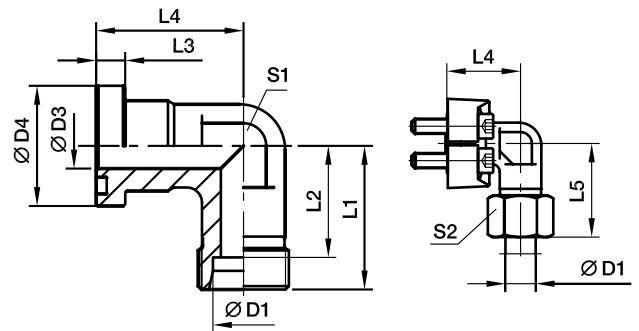

3000 PSI Series

Nom. flange size SAE (in.)	ISO (DN)	D1	D3	D4	L1	L2	L3	L4	L5	S1	S2	Screws	Weight (steel) kg/piece	Order code*	PN (bar)	
															CF	71
1/2	13	12S	12	30.2	50	42.5	6.7	44	58.5	22	24	M 08×25	0.38	WFS32/12S	210	210
1/2	13	15L	12	30.2	36	29.0	6.7	36	44.0	24	27	M 08×25	0.40	WFS32/15L	315	315
1/2	13	16S	12	30.2	38	29.5	6.7	36	48.0	24	30	M 08×25	0.43	WFS32/16S	350	350
1/2	13	18L	12	30.2	50	42.5	6.7	44	59.0	22	32	M 08×25	0.44	WFS32/18L	315	315
3/4	19	16S	19	38.1	64	55.5	6.7	53	73.5	27	30	M 10×30	0.60	WFS33/16S	350	350
3/4	19	18L	19	38.1	39	31.5	6.7	42	48.0	30	32	M 10×30	0.66	WFS33/18L	315	315
3/4	19	22L	19	38.1	41	33.5	6.7	42	50.0	30	36	M 10×30	0.66	WFS33/22L	160	160
3/4	19	20S	17	38.1	43	32.5	6.7	42	54.0	30	36	M 10×30	0.76	WFS33/20S	350	350
3/4	19	25S	17	38.1	45	33.0	6.7	42	57.0	30	46	M 10×30	0.89	WFS33/25S	350	350
1	25	20S	20	44.5	65	54.5	8.0	60	77.0	34	36	M 10×30	0.78	WFS34/20S	350	350
1	25	22L	18	44.5	65	57.5	8.0	60	74.0	34	36	M 10×30	0.81	WFS34/22L	160	160
1	25	28L	25	44.5	44	36.5	8.0	45	53.0	36	41	M 10×30	0.85	WFS34/28L	160	160
1	25	25S	20	44.5	48	36.5	8.0	45	57.0	36	46	M 10×30	0.95	WFS34/25S	350	350
1	25	30S	24	44.5	50	36.5	8.0	45	63.0	36	50	M 10×30	1.06	WFS34/30S	250	250
1 1/4	32	35L	32	50.8	57	46.5	8.0	50	68.0	41	50	M 10×35	1.15	WFS35/35L/10	160	160
1 1/4	32	25S	27	50.8	55	43.0	8.0	60	67.0	41	46	M 10×35	1.35	WFS35/25S/10	200	200
1 1/4	32	30S	28	50.8	57	43.5	8.0	50	70.0	41	50	M 10×35	1.40	WFS35/30S/10	200	200
1 1/4	32	38S	28	50.8	59	43.0	8.0	50	74.0	46	60	M 10×35	1.53	WFS35/38S/10	200	200
1 1/4	32	35L	32	50.8	57	46.5	8.0	50	68.0	41	50	M 12×40	1.15	WFS35/35L	160	160
1 1/4	32	25S	27	50.8	55	43.0	8.0	50	67.0	41	46	M 12×40	1.35	WFS35/25S	200	200
1 1/4	32	30S	28	50.8	57	43.5	8.0	50	70.0	41	50	M 12×40	1.40	WFS35/30S	200	200
1 1/4	32	38S	28	50.8	59	43.0	8.0	50	74.0	41	60	M 12×40	1.53	WFS35/38S	200	200
1 1/2	38	35L	30	60.3	78	67.5	8.0	66	83.0	50	50	M 12×35	1.55	WFS36/35L	160	160
1 1/2	38	42L	36	60.3	58	47.0	8.0	55	70.0	50	60	M 12×35	1.60	WFS36/42L	160	160
1 1/2	38	38S	36	60.3	64	48.0	8.0	55	79.0	50	60	M 12×35	1.95	WFS36/38S	200	200

*Please add suffix 71 after partnumber if stainless steel is required.

WFS - SAE 90° Elbow flange adapter

SAE Flange / EO 24° cone end
(ISO 6162-1/-2)

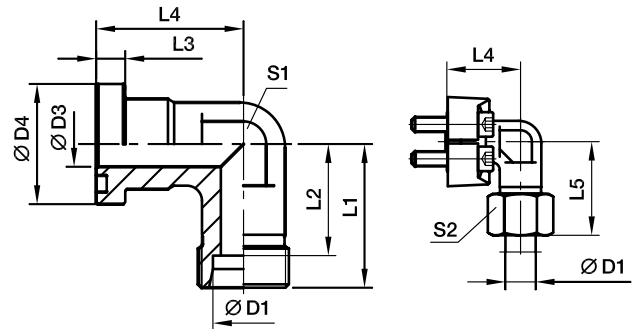

6000 PSI Series

Nom. flange size SAE (in.)	ISO (DN)	D1	D3	D4	L1	L2	L3	L4	L5	S1	S2	Screws	Weight (steel) kg/piece	Order code*	PN (bar)	
															CF	71
1/2	13	12S	12	31.8	50	42.5	7.7	44	58.5	22	24	M 08×30	0.37	WFS62/12S	420	420
1/2	13	14S	12	31.8	50	42.0	7.7	44	59.5	22	27	M 08×30	0.39	WFS62/14S	420	420
1/2	13	16S	12	31.8	38	29.5	7.7	39	48.0	24	30	M 08×30	0.49	WFS62/16S	420	420
3/4	19	16S	17	41.3	45	36.5	8.7	48	55.0	32	30	M 10×35	0.92	WFS63/16S	420	420
3/4	19	20S	17	41.3	46	35.5	8.7	48	57.0	32	36	M 10×35	0.97	WFS63/20S	420	400
3/4	19	25S	17	41.3	48	36.0	8.7	48	60.0	32	46	M 10×35	1.19	WFS63/25S	420	400
1	25	20S	16	47.6	65	54.5	9.5	62	75.0	34	36	M 12×45	1.69	WFS64/20S	420	400
1	25	25S	20	47.6	53	44.0	9.5	60	65.0	41	46	M 12×45	1.67	WFS64/25S	420	400
1	25	30S	25	47.6	55	41.5	9.5	60	68.0	41	50	M 12×45	1.63	WFS64/30S	420	400
1 1/4	32	25S	25	54.0	64	52.0	10.2	55	76.0	42	46	M 12×45	2.23	WFS65/25S/12	420	400
1 1/4	32	30S	30	54.0	58	44.5	10.2	68	71.0	46	50	M 12×45	2.20	WFS65/30S/12	420	400
1 1/4	32	38S	30	54.0	61	45.0	10.2	68	76.0	46	60	M 12×45	2.39	WFS65/38S/12	315	315
1 1/4	32	25S	25	54.0	64	52.0	10.2	55	76.0	42	46	M 14×50	2.23	WFS65/25S	420	400
1 1/4	32	30S	30	54.0	58	44.5	10.2	68	71.0	46	50	M 14×50	2.20	WFS65/30S	420	400
1 1/4	32	38S	30	54.0	61	45.0	10.2	68	76.0	46	60	M 14×50	2.39	WFS65/38S	315	315
1 1/2	38	30S	25	63.5	76	63.5	12.5	77	90.0	50	50	M 16×55	2.38	WFS66/30S	420	400
1 1/2	38	38S	32	63.5	72	56.0	12.5	76	87.0	50	60	M 16×55	2.58	WFS66/38S	315	315

*Please add suffix **71** after partnumber if stainless steel is required.

GFS-G - SAE Straight flange adapter

SAE Flange / BSPP 60° cone end
(ISO 6162-1/-2)

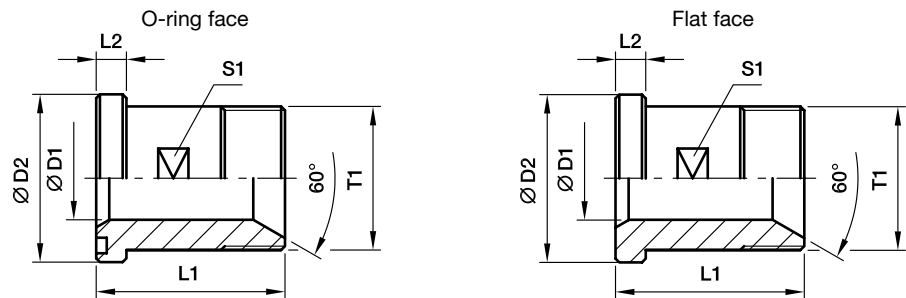

3000 PSI Series

Nom. flange size SAE (in.)	ISO (DN)	T1	D1	D2	L1	L2	S1	Weight (steel) kg/piece	O-ring face	Flat face	PN (bar)	
									Order code*	Order code*	CF	SS
1/2	13	G 1/2	12	30.2	50	6.7	19	0.08	GFS32/12G	GFSG32/12G	345	345
1/2	13	G 3/8	10	30.2	50	6.7	19	0.08	GFS32/38G	GFSG32/38G	345	345
3/4	19	G 3/4	17	38.1	55	6.7	27	0.16	GFS33/34G	GFSG33/34G	345	345
3/4	19	G 1/2	12	38.1	55	6.7	27	0.16	GFS33/12G	GFSG33/12G	345	345
1	25	G 3/4	22	44.4	60	8.0	32	0.23	GFS34/1G	GFSG34/1G	345	345
1	25	G 1	17	44.4	60	8.0	32	0.23	GFS34/34G	GFSG34/34G	345	345
1 1/4	32	G 1 1/4	27	50.8	65	8.0	41	0.30	GFS35/114G	GFSG35/114G	276	276
1 1/4	32	G 1	22	50.8	65	8.0	41	0.30	GFS35/1G	GFSG35/1G	276	276
1 1/2	38	G 1 1/2	32	60.3	70	8.0	46	0.40	GFS36/112G	GFSG36/112G	207	207
1 1/2	38	G 1 1/4	27	60.3	70	8.0	46	0.40	GFS36/114G	GFSG36/114G	207	207
2	51	G 2	40	71.4	75	9.5	55	0.50	GFS38/2G	GFSG38/2G	207	207
2	51	G 1 1/2	32	71.4	75	9.5	55	0.50	GFS38/112G	GFSG38/112G	207	207

6000 PSI Series

1/2	13	G 1/2	12	31.8	50	7.7	19	0.09	GFS62/12G	GFSG62/12G	420	420
1/2	13	G 3/8	10	31.8	50	7.7	19	0.09	GFS62/38G	GFSG62/38G	420	420
3/4	19	G 3/4	17	41.3	60	8.7	26	0.15	GFS63/34G	GFSG63/34G	420	420
3/4	19	G 1/2	12	41.3	60	8.7	26	0.15	GFS63/12G	GFSG63/12G	420	420
1	25	G 1	22	47.6	70	9.5	32	0.23	GFS64/1G	GFSG64/1G	420	420
1	25	G 3/4	17	47.6	70	9.5	32	0.23	GFS64/34G	GFSG64/34G	420	420
1 1/4	32	G 1 1/4	27	54.0	75	10.3	36	0.30	GFS65/114G	GFSG65/114G	420	420
1 1/4	32	G 1	22	54.0	75	10.3	36	0.30	GFS65/1G	GFSG65/1G	420	420
1 1/2	38	G 1 1/2	32	63.5	80	12.5	46	0.50	GFS66/112G	GFSG66/112G	420	420
1 1/2	38	G 1 1/4	27	63.5	80	12.5	46	0.50	GFS66/114G	GFSG66/114G	420	420
2	51	G 2	40	79.4	90	12.5	55	0.80	GFS68/2G	GFSG68/2G	420	420
2	51	G 1 1/2	32	79.4	90	12.5	55	0.80	GFS68/112G	GFSG68/112G	420	420

*Please add suffix 71 after partnumber if stainless steel is required.

WFS-G - SAE 90° Elbow flange adapter

SAE Flange / BSPP 60° cone end
(ISO 6162-1/-2)

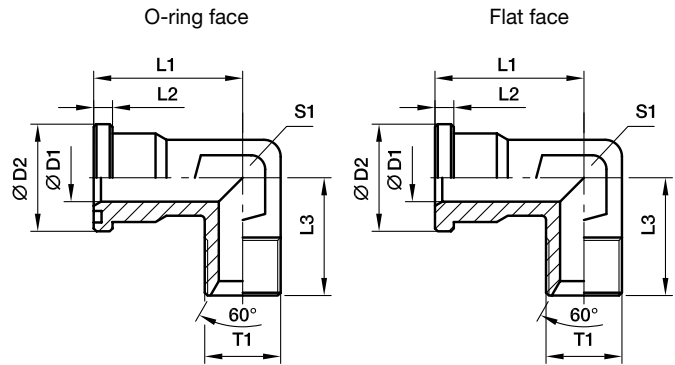

3000 PSI Series

Nom. flange size SAE (in.)	ISO (DN)	T1	D1	D2	L1	L2	L3	S1	Weight (steel) kg/piece	O-ring face	Flat face	PN (bar)	
										Order code*	Order code*	CF	SS
1/2	13	G 1/2	12	30.2	44	6.7	50	22	0.40	WFS32/12G	WFSG32/12G	345	345
1/2	13	G 3/8	10	30.2	44	6.7	50	22	0.34	WFS32/38G	WFSG32/38G	345	345
3/4	19	G 1/2	12	38.1	53	6.7	64	27	0.60	WFS33/12G	WFSG33/12G	345	345
3/4	19	G 3/4	17	38.1	53	6.7	64	27	0.63	WFS33/34G	WFSG33/34G	345	345
3/4	19	G 1	19	38.1	53	6.7	64	27	0.66	WFS33/1G	WFSG33/1G	345	345
1	25	G 3/4	17	44.4	60	8.0	65	34	0.80	WFS34/34G	WFSG34/34G	345	345
1	25	G 1	22	44.4	60	8.0	65	34	0.85	WFS34/1G	WFSG34/1G	345	345
1	25	G 1 1/4	25	44.4	60	8.0	65	34	0.89	WFS34/114G	WFSG34/114G	345	345
1 1/4	32	G 1	22	50.8	55	8.0	64	42	1.16	WFS35/1G	WFSG35/1G	276	276
1 1/4	32	G 1 1/4	28	50.8	55	8.0	64	42	1.27	WFS35/114G	WFSG35/114G	276	276
1 1/2	38	G 1 1/4	28	60.3	66	8.0	78	50	1.90	WFS36/114G	WFSG36/114G	207	207
1 1/2	38	G 1 1/2	34	60.3	66	8.0	78	50	2.05	WFS36/112G	WFSG36/112G	207	207

6000 PSI Series

1/2	13	G 1/2	12	31.8	44	7.7	50	22	0.45	WFS62/12G	WFSG62/12G	420	420
1/2	13	G 3/8	10	31.8	44	7.7	50	22	0.37	WFS62/34G	WFSG62/34G	420	420
3/4	19	G 1/2	14	41.3	53	8.7	64	27	0.88	WFS63/12G	WFSG63/12G	420	420
3/4	19	G 3/4	17	41.3	53	8.7	64	27	0.97	WFS63/34G	WFSG63/34G	420	420
3/4	19	G 1	19	41.3	53	8.7	64	27	1.02	WFS63/1G	WFSG63/1G	420	420
1	25	G 3/4	17	47.6	60	9.5	62	34	1.46	WFS64/34G	WFSG64/34G	420	420
1	25	G 1	22	47.6	60	9.5	62	34	1.57	WFS64/1G	WFSG64/1G	420	420
1	25	G 1 1/4	25	47.6	60	9.5	62	34	1.70	WFS64/114G	WFSG64/114G	420	420
1 1/4	32	G 1	22	54.0	70	10.3	72	42	2.20	WFS65/1G	WFSG65/1G	420	420
1 1/4	32	G 1 1/4	27	54.0	70	10.3	72	42	2.30	WFS65/114G	WFSG65/114G	420	420
1 1/2	38	G 1 1/4	27	63.5	80	12.5	84	50	3.08	WFS66/114G	WFSG66/114G	420	420
1 1/2	38	G 1 1/2	32	63.5	80	12.5	84	50	3.45	WFS66/112G	WFSG 66/112G	420	420

*Please add suffix 71 after partnumber if stainless steel is required.

5125 / 5127 - SAE Straight flange adapter

SAE Flange / Butt weld tube end
(ISO 6162-1/-2)

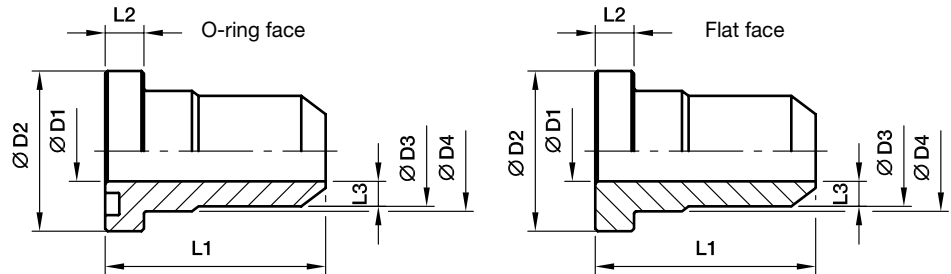

3000 PSI Series

Nom. flange size SAE (in.)	ISO (DN)	Ø Tube	D1	D2	D3	D4	L1	L2	L3	Weight (steel) kg/piece	Order code*		PN (bar)	
											O-ring face	Flat face	S	SS
1/2	13	15×2.0	11	30.2	15	23.9	45.0	6.8	2.0	0.26	5125-015-08	5127-015-08	345	345
1/2	13	16×3.0	10	30.2	16	23.9	45.0	6.8	3.0	0.27	5125-016-08	5127-016-08	345	345
1/2	13	21.3×2.6	13	30.2	22	23.9	45.0	6.8	4.5	0.29	5125-021-08	5127-021-08	345	345
3/4	19	18×1.5	15	38.1	18	31.5	49.9	6.8	1.5	0.51	5125-018-12	5127-018-12	345	345
3/4	19	22×2.0	18	38.1	22	31.5	49.9	6.8	2.0	0.49	5125-022-12	5127-022-12	345	345
3/4	19	20×3.0	14	38.1	20	31.5	49.9	6.8	3.0	0.52	5125-020-12	5127-020-12	345	345
3/4	19	25×4.0	17	38.1	25	31.5	49.9	6.8	4.0	0.49	5125-025-12	5127-025-12	345	345
3/4	19	26.9×2.6	19	38.1	28	31.5	50.0	6.7	4.5	0.51	5125-027-12	5127-027-12	345	345
1	25	20×2.5	15	44.5	20	38.0	55.0	8.0	2.5	0.59	5125-020-16	5127-020-16	345	345
1	25	28×2.0	24	44.5	28	38.0	55.0	8.0	2.0	0.59	5125-028-16	5127-028-16	345	345
1	25	30×4.5	21	44.5	30	38.0	55.0	8.0	4.5	0.62	5125-030-16	5127-030-16	345	345
1	25	33.7×4.0	25	44.4	35	38.0	55.0	8.0	5.0	0.70	5125-034-16	5127-034-16	345	345
1 1/4	32	35×2.0	31	50.8	35	43.0	60.0	8.0	2.0	0.75	5125-035-20	5127-035-20	276	276
1 1/4	32	25×3.0	19	50.8	25	43.0	60.0	8.0	3.0	0.89	5125-025-20	5127-025-20	276	276
1 1/4	32	30×4.0	22	50.8	30	43.0	60.0	8.0	4.0	0.88	5125-030-20	5127-030-20	276	276
1 1/4	32	38×5.0	28	50.8	38	43.0	60.0	8.0	5.0	0.81	5125-038-20	5127-038-20	276	276
1 1/4	32	42.4×6.0	31	50.8	43	43.0	60.0	8.0	6.0	0.92	5125-042-20	5127-042-20	276	276
1 1/2	38	42×3.0	36	60.3	42	50.0	64.9	8.0	3.0	1.03	5125-042-24	5127-042-24	207	207
1 1/2	38	38×4.0	30	60.3	38	50.0	64.9	8.0	4.0	1.17	5125-038-24	5127-038-24	207	207
1 1/2	38	48.3×6.0	38	60.3	50	50.0	65.0	8.0	6.0	1.21	5125-048-24	5127-048-24	207	207
2	51	50×6.0	38	71.4	50	62.0	70.0	9.6	6.0	1.49	5125-050-32	5127-050-32	207	207
2	51	65×8.0	49	71.4	65	62.0	70.0	9.6	8.0	1.38	5125-065-32	5127-065-32	207	207
2	51	60.3×7.5	47	71.4	62	62.0	70.0	9.5	7.5	1.25	5125-060-32	5127-060-32	207	207
2 1/2	64	76.1×5.5	63	84.1	74	74.0	75.0	9.5	5.5	1.50	5125-076-40	5127-076-40	172	172
3	76	88.9×10.0	70	101.6	90	90.0	85.0	9.5	10.0	2.11	5125-090-48	5127-090-48	138	138
3 1/2	89	101.6×7.0	88	114.3	102	102.0	90.0	11.2	7.0	2.51	5125-100-56	5127-100-56	34	34
4	102	114×8.0	98	127.0	114	114.0	100.0	11.2	8.0	2.75	5125-114-64	5127-114-64	34	34
5	127	139.7×10.0	120	152.4	140	140.0	100.0	11.2	10.0	3.41	5125-140-80	5127-140-80	34	34

*Please add suffix **RVS** after partnumber if stainless steel is required.

5126 / 5128 - SAE Straight flange adapter

SAE Flange / Butt weld tube end
(ISO 6162-1/-2)

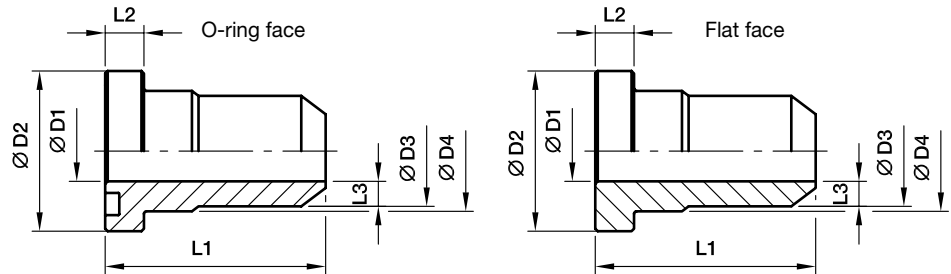

6000 PSI Series

Nom. flange size SAE (in.)	ISO (DN)	Ø Tube	D1	D2	D3	D4	L1	L2	L3	Weight (steel) kg/piece	O-ring face	Flat face	PN (bar)	
											Order code*	Order code*	S	SS
1/2	13	16×3.0	10	31.8	16	24.0	45	7.8	3.0	0.12	5126-016-08	5128-016-08	420	420
1/2	13	21.3×3.2	13	31.8	22	24.0	45	7.8	4.5	0.12	5126-021-08	5128-021-08	420	420
3/4	19	16×3.0	10	41.3	16	31.8	50	8.8	3.0	0.20	5126-016-12	5128-016-12	420	420
3/4	19	20×4.0	12	41.3	20	31.8	50	8.8	4.0	0.22	5126-020-12	5128-020-12	420	420
3/4	19	26.9×4.0	18	41.3	28	32.0	50	8.8	5.0	0.21	5126-027-12	5128-027-12	420	420
3/4	19	25×5.0	15	41.3	25	31.8	50	8.8	5.0	0.21	5126-025-12	5128-025-12	420	420
1	25	25×5.0	15	47.6	25	38.0	55	9.5	5.0	0.34	5126-025-16	5128-025-16	420	420
1	25	30×4.0	22	47.6	30	38.0	55	9.5	4.0	0.30	5126-030-16	5128-030-16	420	420
1	25	33.7×6.3	22	47.6	35	38.0	55	9.5	6.5	0.33	5126-034-16	5128-034-16	420	420
1 1/4	32	30×4.0	22	54.0	30	44.0	60	10.3	4.0	0.53	5126-030-20	5128-030-20	420	420
1 1/4	32	38×5.0	28	54.0	38	44.0	60	10.3	5.0	0.45	5126-038-20	5128-038-20	420	420
1 1/4	32	42.4×6.3	29	54.0	44	44.0	60	10.3	7.5	0.47	5126-042-20	5128-042-20	420	420
1 1/2	38	38×5.0	28	63.5	38	50.8	65	12.6	5.0	0.71	5126-038-24	5128-038-24	420	420
1 1/2	38	48.3×8.0	35	63.5	51	51.0	65	12.6	8.0	0.66	5126-048-24	5128-048-24	420	420
2	51	50×9.0	32	79.4	50	66.6	70	12.6	9.0	1.24	5126-050-32	5128-050-32	420	420
2	51	65×8.0	49	79.4	65	66.6	70	12.6	8.0	0.98	5126-065-32	5128-065-32	420	420
2	51	60.3×10.0	43	79.4	61	67.0	70	12.6	9.0	1.12	5126-061-32	5128-061-32	420	420
2 1/2	64	73×14.0	45	107.8	74	88.9	90	20.6	14.5	6.41	5126-073-40	5128-073-40	420	420
3	76	88.6×16.0	58	131.7	90	113.8	110	25.6	16.0	9.31	5126-089-48	5128-089-48	420	420

*Please add suffix **RVS** after partnumber if stainless steel is required.

5150 / 5151 - SAE Straight 4 bolt flange with BSPP thread

SAE Flange / Female BSPP thread
(ISO 6162-1/-2)

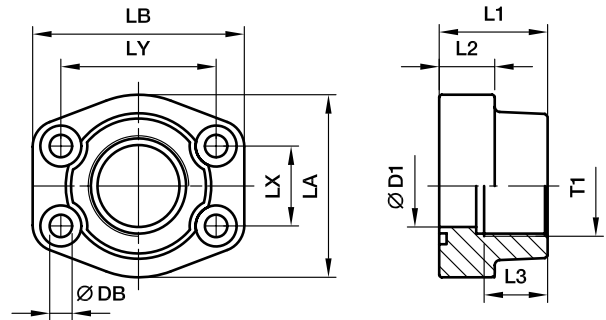

3000 PSI Series

Nom. flange size SAE (in.)	ISO (DN)	T1	D1	L1	L2	L3	LA	LB	LX	LY	DB	Weight (steel) kg/piece	Order code*	PN (bar)	
														S	SS
1/2	13	G 3/8	13	36	16	19	46	57	17.5	38.1	9.0	0.27	5150-06-08	345	345
1/2	13	G 1/2	13	36	16	19	46	57	17.5	38.1	9.0	0.25	5150-08-08	345	345
3/4	19	G 3/4	19	36	18	19	50	65	22.3	47.6	11.0	0.37	5150-12-12	345	345
3/4	13	G 1/2	13	36	18	19	50	65	22.3	47.6	11.0	0.40	5150-08-12	345	345
1	25	G 1	25	38	18	22	55	70	26.2	52.4	11.0	0.45	5150-16-16	345	345
1	19	G 3/4	19	35	21	19	55	70	26.2	52.4	11.0	0.45	5150-12-16	345	345
1 1/4	32	G 1 1/4	32	40	21	22	68	79	30.2	58.7	11.5	0.66	5150-20-20	276	276
1 1/4	25	G 1	25	42	25	22	65	80	30.2	58.7	11.5	0.80	5150-16-20	276	276
1 1/2	38	G 1 1/2	38	45	25	24	78	93	35.7	69.9	13.5	1.05	5150-24-24	207	207
1 1/2	32	G 1 1/4	32	45	27	24	78	95	35.7	69.9	13.5	1.17	5150-20-24	207	207
2	51	G 2	51	45	25	30	89	103	42.9	77.8	13.5	1.17	5150-32-32	207	207
2	38	G 1 1/2	38	45	25	26	89	103	42.9	77.8	13.5	1.52	5150-24-32	207	207
2 1/2	63	G 2 1/2	63	50	25	30	101	115	50.8	88.9	13.5	1.59	5150-40-40	172	172
2 1/2	51	G 2	51	50	25	30	101	115	50.8	88.9	13.5	2.13	5150-32-40	172	172
3	73	G 3	73	50	27	34	124	135	61.9	106.4	17.5	2.28	5150-48-48	138	138
3	63	G 2 1/2	63	50	27	30	124	135	61.9	106.4	17.5	2.56	5150-40-48	138	138
3 1/2	89	G 3 1/2	89	48	27	34	136	152	69.9	120.7	17.5	2.42	5150-56-56	34	34
3 1/2	73	G 3	73	48	27	34	136	152	69.9	120.7	17.5	3.28	5150-48-56	34	34
4	99	G 4	99	48	27	34	146	162	77.8	130.2	17.5	2.78	5150-64-64	34	34
4	89	G 3 1/2	89	48	27	34	146	162	77.8	130.2	17.5	3.30	5150-56-64	34	34
5	129	G 5	120	50	28	30	180	184	92.1	152.4	17.5	5.80	5150-80-80	34	34

6000 PSI Series

1/2	13	G 3/8	13	36	16	19	46	57	18.2	40.5	9.0	0.26	5151-06-08	420	420
1/2	13	G 1/2	13	36	16	19	46	57	18.2	40.5	9.0	0.29	5151-08-08	420	420
3/4	19	G 3/4	19	35	21	22	55	71	23.8	50.8	11.0	0.50	5151-12-12	420	420
3/4	13	G 1/2	13	35	21	22	55	71	23.8	50.8	11.0	0.50	5151-08-12	420	420
1	25	G 1	25	42	25	24	65	81	27.8	57.2	13.0	0.76	5151-16-16	420	420
1	19	G 3/4	19	42	25	24	65	81	27.8	57.2	13.0	0.76	5151-12-16	420	420
1 1/4	32	G 1 1/4	32	45	27	25	78	95	31.8	66.6	13.5	1.20	5151-20-20	420	420
1 1/2	38	G 1 1/2	38	50	30	28	94	112	36.5	79.3	17.0	1.65	5151-24-24	420	420
1 1/2	32	G 1 1/4	32	50	30	28	94	112	36.5	79.3	17.0	1.65	5151-20-24	420	420
2	51	G 2	51	65	37	30	114	134	44.5	96.8	21.0	2.45	5151-32-32	420	420
2	38	G 1 1/2	38	65	37	30	114	134	44.5	96.8	21.0	2.45	5151-24-32	420	420
2 1/2	63	G 2 1/2	63	80	45	32	152	180	58.7	123.8	25.0	3.05	5151-40-40	420	420
3	73	G 3	73	90	55	40	178	208	71.4	152.4	32.0	3.45	5151-48-48	420	420

*Please add suffix **RVS** after partnumber if stainless steel is required.

5152 / 5153 - SAE Straight 4 bolt flange with BSPP thread

SAE Counter flange / Female BSPP thread
(ISO 6162-1/-2)

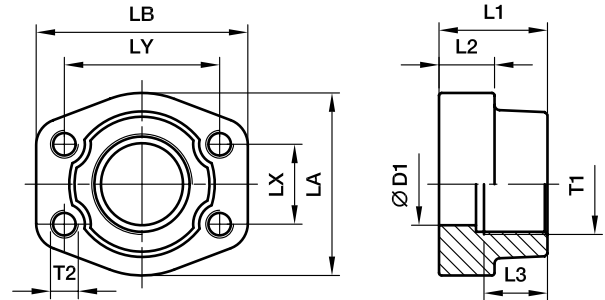

3000 PSI Series

Nom. flange size SAE (in.)	ISO (DN)	T1	D1	L1	L2	L3	LA	LB	LX	LY	Weight (steel) kg/piece	Order code*	PN (bar)	
													S	SS
1/2	13	G 3/8	13	36	16	19	46	57	17.5	38.1	0.26	5152-06-08	345	345
1/2	13	G 1/2	13	36	16	19	46	57	17.5	38.1	0.28	5152-08-08	345	345
3/4	19	G 3/4	19	36	18	19	50	65	22.3	47.6	0.41	5152-12-12	345	345
3/4	13	G 1/2	13	36	18	19	50	65	22.3	47.6	0.44	5152-08-12	345	345
1	25	G 1	25	38	18	22	55	70	26.2	52.4	0.49	5152-16-16	345	345
1	19	G 3/4	19	35	21	19	55	70	26.2	52.4	0.55	5152-12-16	345	345
1 1/4	32	G 1 1/4	32	40	21	22	68	79	30.2	58.7	0.71	5152-20-20	276	276
1 1/4	25	G 1	25	42	25	22	65	80	30.2	58.7	0.85	5152-16-20	276	276
1 1/2	38	G 1 1/2	38	45	25	24	78	93	35.7	69.9	1.12	5152-24-24	207	207
1 1/2	32	G 1 1/4	32	45	27	24	78	95	35.7	69.9	1.24	5152-20-24	207	207
2	51	G 2	51	45	25	30	89	103	42.9	77.8	1.24	5152-32-32	207	207
2	38	G 1 1/2	38	45	25	26	89	103	42.9	77.8	1.59	5152-24-32	207	207
2 1/2	64	G 2 1/2	63	50	25	30	101	115	50.8	88.9	1.66	5152-40-40	172	172
2 1/2	51	G 2	51	50	25	30	101	115	50.8	88.9	2.20	5152-32-40	172	172
3	76	G 3	73	50	27	30	124	135	61.9	106.4	2.37	5152-48-48	138	138
3	63	G 2 1/2	63	50	27	30	124	135	61.9	106.4	2.65	5152-40-48	138	138
3 1/2	89	G 3 1/2	89	50	27	30	136	152	69.9	120.7	2.51	5152-56-56	34	34
3 1/2	73	G 3	73	48	27	34	136	152	69.9	120.7	3.37	5152-48-56	34	34
4	102	G 4	99	50	27	30	146	162	77.8	130.2	2.87	5152-64-64	34	34
4	89	G 3 1/2	89	48	27	34	146	162	77.8	130.2	3.39	5152-56-64	34	34
5	127	G 5	120	50	28	30	180	184	92.1	152.4	5.80	5152-80-80	34	34

6000 PSI Series

1/2	13	G 3/8	13	36	16	19	46	57	18.2	40.5	0.26	5153-06-08	420	420
1/2	13	G 1/2	13	36	16	19	46	57	18.2	40.5	0.29	5153-08-08	420	420
3/4	19	G 3/4	19	35	21	22	55	71	23.8	50.8	0.55	5153-12-12	420	420
3/4	13	G 1/2	13	35	21	22	55	71	23.8	50.8	0.60	5153-08-12	420	420
1	25	G 1	25	42	25	24	65	81	27.8	57.2	0.87	5153-16-16	420	420
1	19	G 3/4	19	42	25	24	65	81	27.8	57.2	0.90	5153-12-16	420	420
1 1/4	32	G 1 1/4	32	45	27	25	78	95	31.8	66.6	1.21	5153-20-20	420	420
1 1/4	25	G 1	25	45	27	25	78	95	31.8	66.6	1.34	5153-16-20	420	420
1 1/2	38	G 1 1/2	38	50	30	28	94	112	36.5	79.3	1.90	5153-24-24	420	420
1 1/2	32	G 1 1/4	32	50	30	28	94	112	36.5	79.3	2.03	5153-20-24	420	420
2	51	G 2	51	65	37	30	114	134	44.5	96.8	3.43	5153-32-32	420	420
2	38	G 1 1/2	38	65	37	30	114	134	44.5	96.8	3.92	5153-24-32	420	420
2 1/2	64	G 2 1/2	63	80	45	32	152	180	58.7	123.8	6.98	5153-40-40	420	420
3	76	G 3	73	90	55	40	178	208	71.4	152.4	13.00	5153-48-48	420	420

*Please add suffix **RVS** after partnumber if stainless steel is required.

5102 / 5103 - SAE 90° 4 bolt flange with BSPP thread

SAE 90° Flange / Female BSPP thread
(ISO 6162-1/-2)

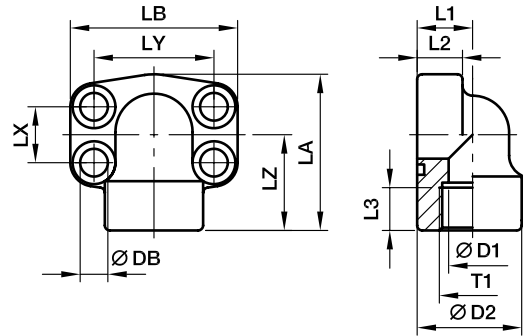

3000 PSI Series

Nom. flange size		T1	D1	D2	L1	L2	L3	LA	LB	LX	LY	LZ	DB	Weight (steel) kg/piece	Order code*	PN (bar)	
SAE (in.)	ISO (DN)															S	SS
1/2	13	G 1/2	13	34.0	18	16	16	59	57	17.5	38.1	36	9.0	0.35	5102-08-08	348	348
3/4	19	G 3/4	19	38.5	22	18	19	63	68	22.3	47.6	38	10.5	0.55	5102-12-12	348	348
1	25	G 1	25	44.5	28	19	19	68	74	26.2	52.4	41	10.5	0.80	5102-16-16	348	348
1 1/4	32	G 1 1/4	31	53.5	30	22	22	84	81	30.2	58.7	50	10.5	1.30	5102-20-20	278	278
1 1/2	38	G 1 1/2	38	62.5	36	25	24	97	95	35.7	69.9	58	13.5	1.60	5102-24-24	210	210
2	51	G 2	50	77.0	41	25	26	109	105	42.9	77.8	65	13.5	2.00	5102-32-32	210	210
2 1/2	64	G 2 1/2	60	89.0	50	25	30	127	115	50.8	88.9	77	13.5	2.40	5102-40-40	175	175

6000 PSI Series

1/2	13	G 1/2	13	34.0	18	16	16	59	57	18.2	40.5	36	8.8	0.35	5103-08-08	420	420
3/4	19	G 3/4	19	44.5	28	20	22	68	72	23.8	50.8	41	10.5	0.80	5103-12-12	420	420
1	25	G 1	25	53.5	30	24	24	84	82	27.8	57.2	50	13.5	1.30	5103-16-16	420	420
1 1/4	32	G 1 1/4	31	62.5	36	25	25	97	95	31.8	66.6	58	15.0	1.60	5103-20-20	420	420
1 1/2	38	G 1 1/2	38	77.0	51	26	28	109	110	36.5	79.3	65	17.0	2.00	5103-24-24	420	420
2	51	G 2	50	87.0	45	35	34	133	134	44.5	96.8	75	21.0	2.50	5103-32-32	420	420

*Please add suffix **RVS** after partnumber if stainless steel is required.

5150N / 5151N - SAE Straight 4 bolt flange with NPT thread

SAE Flange / Female NPT thread
(ISO 6162-1/-2)

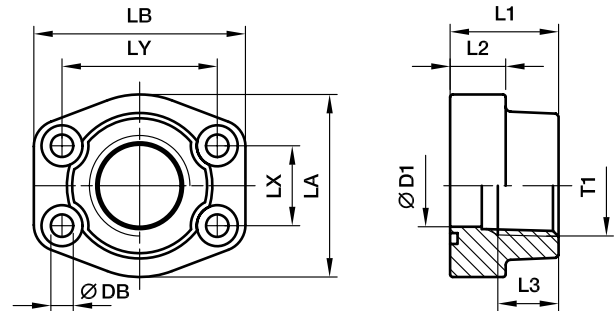

3000 PSI Series

Nom. flange size SAE (in.)	ISO (DN)	T1	D1	L1	L2	L3	LA	LB	LX	LY	DB	Weight (steel) kg/piece	Order code*	PN (bar)	
														S	SS
1/2	13	3/8 NPT	13	36	16	15	46	58	17.5	38.1	9.0	0.25	5150N-06-08	345	345
1/2	13	1/2 NPT	13	36	16	15	46	58	17.5	38.1	9.0	0.28	5150N-08-08	345	345
3/4	19	3/4 NPT	19	36	18	19	49	66	22.3	47.6	10.5	0.39	5150N-12-12	345	345
1	25	1 NPT	25	38	18	19	53	71	26.2	52.4	10.5	0.46	5150N-16-16	345	345
1 1/4	32	1 1/4 NPT	31	41	21	22	69	80	30.2	58.7	10.5	0.66	5150N-20-20	276	276
1 1/2	38	1 1/2 NPT	38	44	25	24	77	94	35.7	69.9	13.5	1.05	5150N-24-24	207	207
2	51	2 NPT	50	45	25	26	89	103	42.9	77.8	13.5	1.19	5150N-32-32	207	207
2 1/2	64	2 1/2 NPT	63	50	25	30	101	115	50.8	88.9	13.5	1.40	5150N-40-40	172	172
3	76	3 NPT	73	50	27	34	124	135	61.9	106.4	17.0	2.15	5150N-48-48	138	138
3 1/2	89	3 1/2 NPT	89	50	27	36	136	152	69.9	120.7	17.0	2.40	5150N-56-56	34	34
4	102	4 NPT	99	50	27	36	146	162	77.8	130.2	17.0	2.85	5150N-64-64	34	34
5	127	5 NPT	120	50	28	36	180	184	92.1	152.4	17.0	3.25	5150N-80-80	34	34

6000 PSI Series

1/2	13	3/8 NPT	13	36	16	15	46	58	18.2	40.5	9.0	0.26	5151N-06-08	420	420
1/2	13	1/2 NPT	13	36	16	15	46	58	18.2	40.5	9.0	0.29	5151N-08-08	420	420
3/4	19	3/4 NPT	19	36	19	22	53	71	23.8	50.8	10.5	0.50	5151N-12-12	420	420
1	25	1 NPT	25	44	24	24	69	80	27.8	57.2	13.5	0.76	5151N-16-16	420	420
1 1/4	32	1 1/4 NPT	31	44	27	25	77	94	31.8	66.6	15.0	1.20	5151N-20-20	420	420
1 1/2	38	1 1/2 NPT	38	51	30	28	89	106	36.5	79.3	17.0	1.65	5151N-24-24	420	420
2	51	2 NPT	50	70	37	33	116	135	44.5	96.8	21.0	2.45	5151N-32-32	420	420
2 1/2	64	2 1/2 NPT	63	75	45	35	150	166	58.7	123.8	25.0	3.05	5151N-40-40	420	420
3	76	3 NPT	73	90	55	40	178	208	71.4	152.4	32.0	3.45	5151N-48-48	420	420

*Please add suffix **RVS** after partnumber if stainless steel is required.

5152N / 5153N - SAE Straight 4 bolt flange with NPT thread

SAE Counter flange / Female NPT thread
(ISO 6162-1/-2)

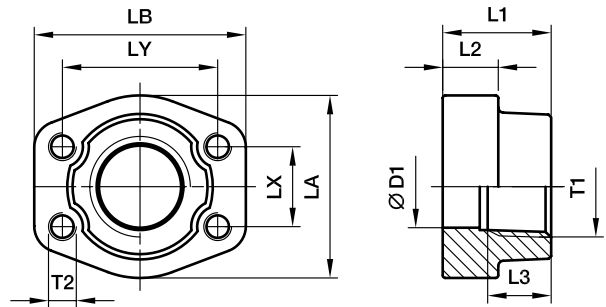

3000 PSI Series

Nom. flange size SAE (in.)	ISO (DN)	T1	D1	L1	L2	L3	LA	LB	LX	LY	Weight (steel) kg/piece	Order code*	PN (bar)	
													S	SS
1/2	13	3/8 NPT	13	36	16	19	47	57	17.5	38.1	0.25	5152N-06-08	345	345
1/2	13	1/2 NPT	13	36	16	19	47	57	17.5	38.1	0.28	5152N-08-08	345	345
3/4	19	3/4 NPT	19	36	18	19	49	66	22.3	47.6	0.39	5152N-12-12	345	345
1	25	1 NPT	25	38	18	19	53	71	26.2	52.4	0.46	5152N-16-16	345	345
1 1/4	32	1 1/4 NPT	31	41	21	22	69	80	30.2	58.7	0.66	5152N-20-20	276	276
1 1/2		1 1/2 NPT	38	44	25	24	77	94	35.7	69.9	1.05	5152N-24-24	207	207
2	51	2 NPT	50	45	25	26	89	103	42.9	77.8	1.19	5152N-32-32	207	207
2 1/2	64	2 1/2 NPT	63	50	25	30	101	115	50.8	88.9	1.40	5152N-40-40	172	172
3	76	3 NPT	73	50	27	30	124	135	61.9	106.4	2.15	5152N-48-48	138	138
3 1/2	89	3 1/2 NPT	89	50	27	30	136	152	69.9	120.7	2.40	5152N-56-56	34	34
4	102	4 NPT	99	50	27	30	146	162	77.8	130.2	2.85	5152N-64-64	34	34
5	127	5 NPT	120	50	28	30	180	184	92.1	152.4	3.25	5152N-80-80	34	34

6000 PSI Series

1/2	13	3/8 NPT	13	36	16	19	47	57	18.2	40.5	0.26	5153N-06-08	420	420
1/2	13	1/2 NPT	13	36	16	19	47	57	18.2	40.5	0.29	5153N-08-08	420	420
3/4	19	3/4 NPT	19	36	19	22	53	71	23.8	50.8	0.50	5153N-12-12	420	420
1	25	1 NPT	25	44	24	24	69	80	27.8	57.2	0.76	5153N-16-16	420	420
1 1/4	32	1 1/4 NPT	31	44	27	25	77	94	31.8	66.6	1.20	5153N-20-20	420	420
1 1/2	32	1 1/2 NPT	38	51	30	28	89	106	36.5	79.3	1.65	5153N-24-24	420	420
2	51	2 NPT	50	70	37	33	116	135	44.5	96.8	2.45	5153N-32-32	420	420
2 1/2	64	2 1/2 NPT	63	75	45	35	150	166	58.7	123.8	3.05	5153N-40-40	420	420
3	76	3 NPT	73	90	55	40	178	208	71.4	152.4	3.45	5153N-48-48	420	420

*Please add suffix **RVS** after partnumber if stainless steel is required.

5102N / 5103N - SAE 90° 4 bolt flange with NPT thread

SAE 90° Flange / Female NPT thread
(ISO 6162-1/-2)

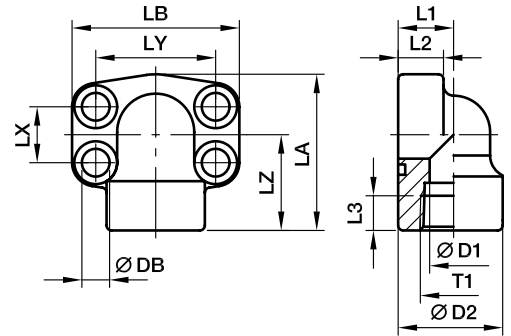

3000 PSI Series

Nom. flange size SAE (in.)	ISO (DN)	T1	D1	D2	L1	L2	L3	LA	LB	LX	LY	LZ	DB	Weight (steel) kg/piece	Order code*	PN (bar)	
																S	SS
1/2	13	1/2 NPT	13	34.0	18	16	16	59	56	17.5	38.1	36	9.0	0.35	5102N-08-08	348	348
3/4	19	3/4 NPT	19	38.5	22	18	19	63	68	22.3	47.6	38	10.5	0.55	5102N-12-12	348	348
1	25	1 NPT	25	44.5	28	19	19	68	74	26.2	52.4	41	10.5	0.80	5102N-16-16	348	348
1 1/4	32	1 1/4 NPT	31	53.5	30	22	22	84	81	30.2	58.7	50	10.5	1.30	5102N-20-20	278	278
1 1/2	38	1 1/2 NPT	38	62.5	36	25	24	97	95	35.7	69.9	58	13.5	1.60	5102N-24-24	210	210
2	51	2 NPT	50	77.0	41	25	26	109	105	42.9	77.8	65	13.5	2.00	5102N-32-32	210	210
2 1/2	64	2 1/2 NPT	60	89.0	50	25	30	127	115	50.8	88.9	77	13.5	2.40	5102N-40-40	175	175

6000 PSI Series

1/2	13	1/2 NPT	13	34.0	18	16	16	59	56	18.2	40.5	36	9.0	0.35	5103N-08-08	420	420
3/4	19	3/4 NPT	19	44.5	28	20	22	68	72	23.8	50.8	41	10.5	0.80	5103N-12-12	420	420
1	25	1 NPT	25	53.5	30	24	24	84	82	27.8	57.2	50	13.5	1.30	5103N-16-16	420	420
1 1/4	32	1 1/4 NPT	31	62.5	36	25	25	97	95	31.8	66.6	58	15.0	1.60	5103N-20-20	420	420
1 1/2	38	1 1/2 NPT	38	77.0	51	26	28	109	110	36.5	79.3	65	17.0	2.00	5103N-24-24	420	420
2	51	2 NPT	50	87.0	45	35	34	133	134	44.5	96.8	75	21.0	2.50	5103N-32-32	420	420

*Please add suffix **RVS** after partnumber if stainless steel is required.

Flanges

5142 / 5143 - SAE Straight 4 bolt flange (butt weld)

SAE Flange / Butt weld tube end
(ISO 6162-1/-2)

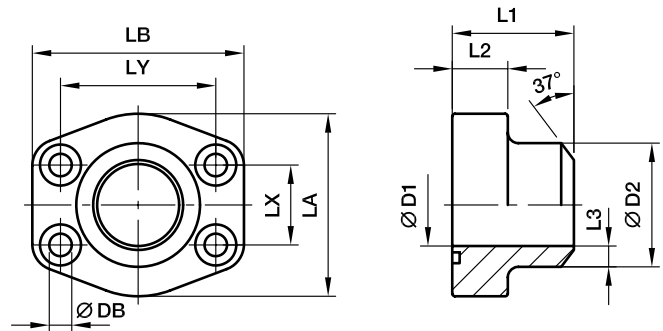

3000 PSI Series

Nom. flange size SAE (in.)	ISO (DN)	Ø max.	D1	D2	L1	L2	L3	LA	LB	LX	LY	DB	Weight (steel) kg/piece	PN (bar)		
														Order code*	S	SS
1/2	13	21.3	13	21.6	36	16	4.3	46	58	17.5	38.1	9.0	0.28	5142-021-08	345	345
3/4	19	26.9	19	27.2	36	18	4.1	49	66	22.3	47.6	10.5	0.39	5142-028-12	345	345
1	25	33.7	25	34.5	38	18	4.7	53	71	26.2	52.4	10.5	0.46	5142-034-16	345	345
1 1/4	32	42.4	31	42.8	41	21	3.0	69	80	30.2	58.7	10.5	0.66	5142-042-20	276	276
1 1/2	38	48.3	38	48.6	44	25	5.3	77	94	35.7	69.9	13.5	1.05	5142-048-24	207	207
2	51	60.3	50	61.0	45	25	5.5	89	103	42.9	77.8	13.5	1.19	5142-061-32	207	207
2 1/2	64	76.1	63	76.6	50	25	6.8	101	115	50.8	88.9	13.5	1.40	5142-077-40	172	172
3	76	88.9	73	89.0	50	27	8.0	124	135	61.9	106.4	17.0	2.15	5142-092-48	138	138
3 1/2	89	101.6	89	103.0	50	27	7.0	134	153	69.9	120.7	17.0	2.40	5142-103-56	34	34
4	102	114.3	99	115.0	50	27	8.0	147	163	77.8	130.2	17.0	2.85	5142-115-64	34	34
5	127	140.0	120	141.0	50	28	10.5	180	184	92.1	152.4	17.0	4.85	5142-140-80	34	34

6000 PSI Series

1/2	13	17.2	10	17.5	36	18	3.7	46	58	18.2	40.5	9.0	0.26	5143-017-08	420	420
1/2	13	21.3	13	21.6	36	18	4.3	46	58	18.2	40.5	9.0	0.29	5143-021-08	420	420
3/4	19	26.9	18	27.2	36	18	4.6	53	71	23.8	50.8	10.5	0.50	5143-028-12	420	420
1	25	33.7	22	34.5	44	24	6.3	66	80	27.8	57.2	10.5	0.76	5143-034-16	420	420
1 1/4	32	42.4	28	42.8	44	25	7.4	77	94	31.8	66.6	15.0	1.35	5143-042-20	420	420
1 1/2	38	48.3	32	48.6	51	29	8.3	89	106	36.5	79.3	17.0	1.80	5143-048-24	420	420
2	51	60.3	41	61.0	70	35	10.0	116	135	44.5	96.8	21.0	2.45	5143-061-32	420	420
2 1/2	64	76.1	50	76.6	75	45	13.0	150	166	58.7	123.8	25.0	6.25	5143-076-40	420	420
3	76	88.9	58	90.0	90	55	16.0	178	208	71.4	152.4	32.0	8.10	5143-090-48	420	420

*Please add suffix **RVS** after partnumber if stainless steel is required.

5144 / 5145 - SAE Straight 4 bolt counter flange (butt weld)

SAE Counter flange / Butt weld tube end
(ISO 6162-1/-2)

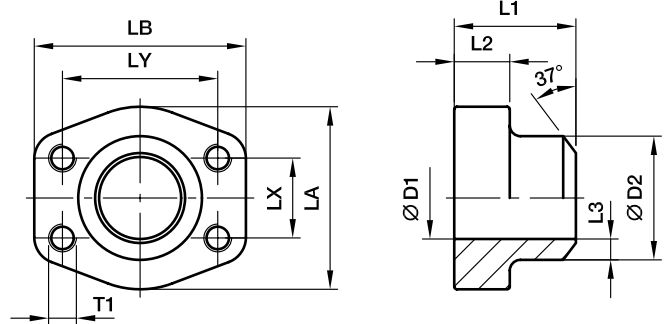

3000 PSI Series

Nom. flange size SAE (in.)	ISO (DN)	Ø max.	D1	D2	L1	L2	L3	LA	LB	LX	LY	Weight (steel) kg/piece	Order code*	PN (bar)	
														S	SS
1/2	13	21.3	13	21.6	36	16	4.3	47	57	17.5	38.1	0.25	5144-021-08	345	345
3/4	19	26.9	19	27.2	36	18	4.1	49	66	22.3	47.6	0.35	5144-028-12	345	345
1	25	33.7	25	34.5	38	18	4.7	53	71	26.2	52.4	0.46	5144-034-16	345	345
1 1/4	32	42.4	31	42.8	41	21	6.0	69	80	30.2	58.7	0.66	5144-042-20	276	276
1 1/2	38	48.3	38	48.6	44	25	5.3	77	94	35.7	69.9	1.05	5144-048-24	207	207
2	51	60.3	50	61.0	45	25	5.5	89	103	42.9	77.8	1.19	5144-061-32	207	207
2 1/2	64	76.1	63	76.6	50	25	6.8	101	115	50.8	88.9	1.40	5144-077-40	172	172
3	76	88.9	73	89.0	50	27	8.0	124	135	61.9	106.4	2.15	5144-092-48	138	138
3 1/2	89	101.6	89	103.0	50	27	7.0	134	153	69.9	120.7	2.40	5144-103-56	34	34
4	102	114.3	99	115.0	50	27	8.0	147	163	77.8	130.2	2.85	5144-115-64	34	34
5	127	140.0	120	141.0	50	28	10.5	180	184	92.1	152.4	4.90	5144-140-80	34	34

6000 PSI Series

1/2	13	17.2	10	17.5	36	16	3.7	47	57	18.2	40.5	0.29	5145-017-08	420	420
1/2	13	21.3	13	21.6	36	16	4.3	47	57	18.2	40.5	0.26	5145-021-08	420	420
3/4	19	26.9	18	27.2	36	19	4.6	53	71	23.8	50.8	0.50	5145-028-12	420	420
1	25	33.7	22	34.5	44	24	6.3	66	80	27.8	57.2	0.76	5145-034-16	420	420
1 1/4	32	42.4	28	42.8	44	27	7.4	77	94	31.8	66.6	1.20	5145-042-20	420	420
1 1/2	38	48.3	32	48.6	51	30	8.3	89	106	36.5	79.3	1.65	5145-048-24	420	420
2	51	60.3	41	61.0	70	37	10.0	116	135	44.5	96.8	2.75	5145-061-32	420	420
2 1/2	64	76.1	50	76.6	75	45	13.0	150	166	58.7	123.8	6.40	5145-076-40	420	420
3	76	88.9	58	90.0	90	55	16.0	178	208	71.4	152.4	8.25	5145-090-48	420	420

*Please add suffix **RVS** after partnumber if stainless steel is required.

5167 / 5168 - SAE 90° 4 bolt flange (butt weld)

SAE 90° Flange / Butt weld tube end
(ISO 6162-1/-2)

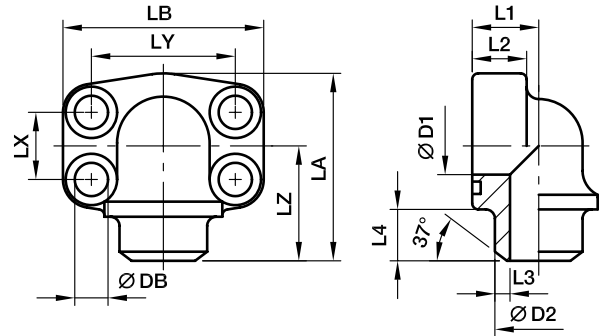

3000 PSI Series

Nom. flange size SAE (in.)	ISO (DN)	Ø max.	D1	D2	L1	L2	L3	L4	LA	LB	LX	LY	LZ	DB	Weight (steel) kg/piece	Order code*	PN (bar)	
																	S	SS
1/2	13	21.3	13	21.6	18	16	4.3	12	63	56	17.5	38.1	40	9.0	0.45	5167-021-08	345	345
3/4	19	26.9	19	27.2	22	18	4.1	12	74	68	22.3	47.6	41	10.5	0.65	5167-027-12	345	345
1	25	33.7	25	34.5	28	19	4.7	13	77	74	26.2	52.4	50	10.5	0.85	5167-034-16	345	345
1 1/4	32	42.4	31	42.8	30	22	6.0	13	91	81	30.2	58.7	57	10.5	1.15	5167-042-20	276	276
1 1/2	38	48.3	38	48.6	36	25	5.3	14	105	95	35.7	69.9	66	13.5	1.70	5167-048-24	207	207
2	51	60.3	50	61.0	41	25	5.5	15	110	105	42.9	77.8	66	13.5	2.15	5167-060-32	207	207
2 1/2	64	76.1	60	76.6	50	25	8.0	25	127	115	50.8	88.9	77	13.5	2.95	5167-076-40	172	172

6000 PSI Series

1/2	13	21.3	13	21.6	18	16	4.3	12	63	56	18.2	40.5	40	9.0	0.50	5168-021-08	420	420
3/4	19	26.9	18	27.2	28	20	4.6	12	77	72	23.8	50.8	50	10.5	0.55	5168-027-12	420	420
1	25	33.7	22	34.5	26	24	6.3	13	91	82	27.8	57.2	57	13.5	0.80	5168-034-16	420	420
1 1/4	32	42.4	28	42.8	36	25	7.4	13	105	95	31.8	66.6	66	15.0	1.15	5168-042-20	420	420
1 1/2	38	48.3	32	48.6	41	26	8.3	15	109	110	36.5	79.3	65	17.0	2.00	5168-048-24	420	420
2	51	60.3	41	61.0	45	35	10.0	15	133	134	44.5	96.8	75	21.0	3.00	5168-060-32	420	420

*Please add suffix **RVS** after partnumber if stainless steel is required.

5138 / 5139 - SAE Straight 4 bolt flange (socket weld)

SAE Flange / Socket weld tube end
(ISO 6162-1/-2)

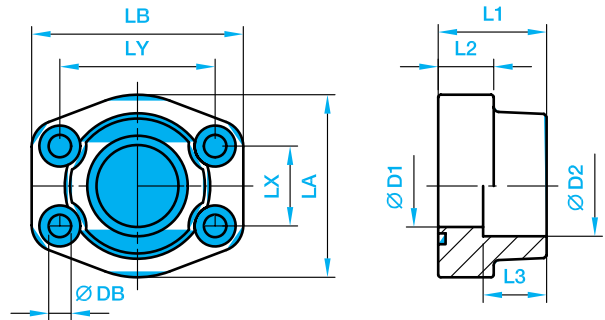

3000 PSI Series

Nom. flange size SAE (in.)	ISO (DN)	Ø max.	D1	D2	L1	L2	L3	LA	LB	LX	LY	DB	Weight (steel) kg/piece	Order code*	PN (bar)	
															S	SS
1/2	13	17.2	13	17.5	36	16	18	46	58	17.5	38.1	9.0	0.25	5138-017-08	345	345
1/2	13	21.3	13	21.6	36	16	18	46	58	17.5	38.1	9.0	0.28	5138-021-08	345	345
3/4	19	26.9	19	27.2	36	18	18	49	66	22.3	47.6	10.5	0.39	5138-027-12	345	345
1	25	33.7	25	34.1	38	18	18	53	70	26.2	52.4	10.3	0.46	5138-034-16	345	345
1 1/4	32	42.4	31	42.8	41	21	20	69	80	30.2	58.7	10.5	0.66	5138-042-20	276	276
1 1/2	38	48.3	38	48.6	44	25	22	77	94	35.7	69.9	13.5	1.05	5138-048-24	207	207
2	51	60.3	50	61.0	45	25	24	89	103	42.9	77.8	13.5	1.19	5138-060-32	207	207
2 1/2	64	76.1	63	76.6	50	25	28	101	115	50.8	88.9	13.5	1.40	5138-076-40	172	172
3	76	88.9	73	90.5	50	27	28	124	135	61.9	106.4	17.0	2.15	5138-090-48	138	138
3 1/2	89	101.6	89	103.0	50	27	28	137	153	69.9	120.7	17.0	2.40	5138-103-56	34	34
4	102	114.3	99	115.5	50	27	28	147	163	77.8	130.2	17.0	2.85	5138-115-64	34	34
5	127	140.0	120	142.0	50	28	28	180	184	92.1	152.4	17.0	3.25	5138-040-80	34	34

6000 PSI Series

1/2	13	17.2	13	17.5	36	16	18	46	58	18.2	40.5	9.0	0.26	5139-017-08	420	420
1/2	13	21.3	13	21.6	36	16	18	46	58	18.2	40.5	9.0	0.29	5139-021-08	420	420
3/4	19	26.9	19	27.2	36	19	20	53	71	23.8	50.8	10.3	0.50	5139-027-12	420	420
1	25	33.7	25	34.1	44	24	22	66	80	27.8	57.2	13.5	0.76	5139-034-16	420	420
1 1/4	32	42.4	31	42.8	44	27	22	77	94	31.8	66.6	15.0	1.20	5139-042-20	420	420
1 1/2	38	48.3	38	48.6	51	30	24	89	106	36.5	79.3	17.0	1.65	5139-048-24	420	420
2	51	60.3	50	61.0	70	37	25	116	135	44.5	96.8	21.0	2.45	5139-060-32	420	420
2 1/2	64	76.1	63	76.6	75	45	28	150	166	58.7	123.8	25.0	3.05	5139-076-40	420	420
3	76	88.9	73	90.5	90	55	30	178	208	71.4	152.4	32.0	3.45	5139-090-48	420	420

*Please add suffix **RVS** after partnumber if stainless steel is required.

5140 / 5141 - SAE Straight counter 4 bolt flange (socket weld)

SAE Counter flange / Socket weld tube end
(ISO 6162-1/-2)

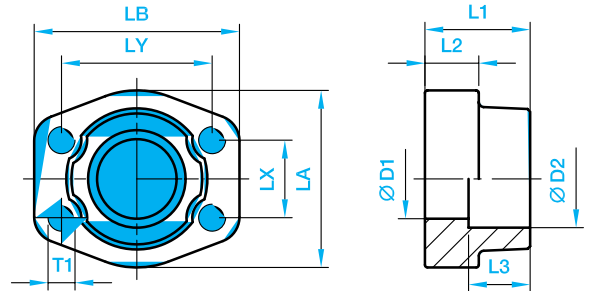

3000 PSI Series

Nom. flange size SAE (in.)	ISO (DN)	Ø max.	D1	D2	L1	L2	L3	LA	LB	LX	LY	DB	Screws		Weight (steel) kg/piece	Order code*	PN (bar)	
													(metr.)	(unc.)			S	SS
1/2	13	17.2	13	17.5	36	18	16	46	58	17.5	38.1	9.0	M 8	5/16	0.25	5140-017-08	345	345
1/2	13	21.3	13	21.6	36	18	16	46	58	17.5	38.1	9.0	M 8	5/16	0.28	5140-021-08	345	345
3/4	19	26.9	19	27.2	36	18	18	49	66	22.3	47.6	10.5	M10	3/8	0.39	5140-027-12	345	345
1	25	33.7	25	34.1	38	18	18	53	70	26.2	52.4	10.5	M10	3/8	0.46	5140-034-16	345	345
1 1/4	32	42.4	31	42.8	41	20	21	69	80	30.2	58.7	10.5	M10	7/16	0.66	5140-042-20	276	276
1 1/2	38	48.3	38	48.6	44	22	25	77	94	35.7	69.9	13.5	M12	1/2	1.05	5140-048-24	207	207
2	51	60.3	50	61.0	45	24	25	89	103	42.9	77.8	13.5	M12	1/2	1.19	5140-061-32	207	207
2 1/2	64	76.1	63	76.6	50	28	25	101	115	50.8	88.9	13.5	M12	1/2	1.40	5140-076-40	172	172
3	76	88.9	73	90.5	50	28	27	124	135	61.9	106.4	17.0	M16	5/8	2.15	5140-090-48	138	138
3 1/2	89	101.6	89	103.0	50	28	27	137	153	69.9	120.7	17.0	M16	5/8	2.40	5140-103-56	34	34
4	102	114.3	99	115.5	50	28	27	147	163	77.8	130.2	17.0	M16	5/8	2.85	5140-115-64	34	34
5	127	140.0	120	142.0	50	28	28	180	184	92.1	152.4	17.0	M16	5/8	3.25	5140-140-80	34	34

6000 PSI Series

1/2	13	17.2	13	17.5	36	18	16	46	58	18.2	40.5	9.0	M 8	5/16	0.26	5141-017-08	420	420
1/2	13	21.3	13	21.6	36	18	16	46	58	18.2	40.5	9.0	M 8	5/16	0.29	5141-021-08	420	420
3/4	19	26.9	19	27.2	36	20	19	53	71	23.8	50.8	10.5	M10	3/8	0.50	5141-027-12	420	420
1	25	33.7	25	34.1	44	22	24	66	80	27.8	57.2	13.5	M12	7/16	0.76	5141-034-16	420	420
1 1/4	32	42.4	31	42.8	44	22	27	77	94	31.8	66.6	15.0	M14	1/2	1.20	5141-042-20	420	420
1 1/2	38	48.3	38	48.6	51	24	30	89	106	36.5	79.3	17.0	M16	5/8	1.65	5141-048-24	420	420
2	51	60.3	50	61.0	70	25	37	116	135	44.5	96.8	21.0	M20	3/4	2.45	5141-061-32	420	420
2 1/2	64	76.1	63	76.6	75	28	45	150	166	58.7	123.8	25.0	M24	-	3.05	5141-076-40	420	420
3	76	88.9	73	90.5	90	30	55	178	208	71.4	152.4	32.0	M30	-	3.45	5141-090-48	420	420

*Please add suffix **RVS** after partnumber if stainless steel is required.

5106 / 5107 - SAE 90° 4 bolt flange (socket weld)

SAE 90° Flange / Socket weld tube end
(ISO 6162-1/-2)

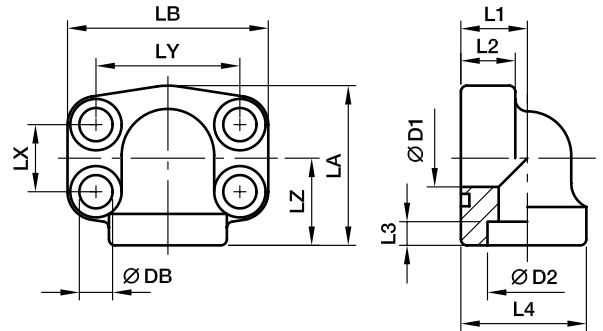

3000 PSI Series

Nom. flange size SAE (in.)	ISO (DN)	Ø max.	D1	D2	L1	L2	L3	L4	LA	LB	LX	LY	LZ	DB	Weight (steel) kg/piece	Order code*	PN (bar)	
																	S	SS
1/2	13	21.3	13	21.6	18	17	5	34.0	51	57	17.5	38.1	28	9.0	0.35	5106-021-08	345	345
3/4	19	26.9	19	27.2	22	18	5	38.5	50	68	22.2	47.6	25	10.5	0.55	5106-027-12	345	345
1	25	33.7	25	34.1	28	19	6	44.5	55	72	26.2	52.4	28	10.5	0.80	5106-034-16	345	345
1 1/4	32	42.4	31	42.8	30	22	7	53.5	68	82	30.2	58.7	34	10.5	1.30	5106-042-20	276	276
1 1/2	38	48.3	38	48.6	36	25	8	62.5	82	95	35.7	69.9	43	13.5	1.60	5106-048-24	207	207
2	51	60.3	50	61.0	41	25	10	77.0	94	105	42.9	77.8	50	13.5	2.00	5106-061-32	207	207
2 1/2	64	76.1	60	76.6	50	25	28	85.0	127	115	50.8	88.9	77	13.5	2.60	5106-076-40	172	172

6000 PSI Series

1/2	13	21.3	13	21.6	18	17	5	34.0	51	57	18.2	40.5	28	9.0	0.35	5107-021-08	420	420
3/4	19	26.9	19	27.2	28	19	6	44.5	55	72	23.8	50.8	28	10.5	0.80	5107-027-12	420	420
1	25	33.7	25	34.1	30	24	7	53.5	68	82	27.8	57.2	34	13.5	1.30	5107-034-16	420	420
1 1/4	32	42.4	31	42.8	36	25	8	62.5	82	95	31.8	66.6	43	15.0	1.60	5107-042-20	420	420
1 1/2	38	48.3	38	48.6	41	26	10	77.0	94	110	36.5	79.3	50	17.0	2.00	5107-048-24	420	420
2	51	60.3	50	61.0	45	35	12	89.0	123	134	44.5	96.8	65	21.0	2.50	5107-061-32	420	420

*Please add suffix **RVS** after partnumber if stainless steel is required.

5146 / 5147 - SAE Closed flange

SAE Closed flange
(ISO 6162-1/-2)

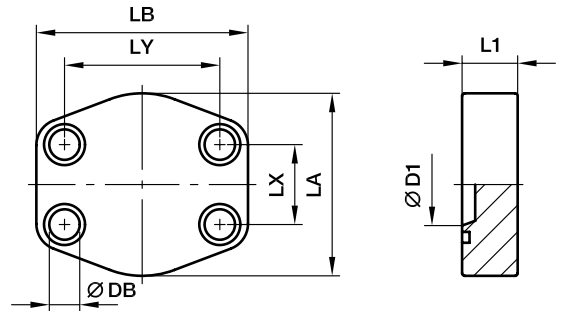

3000 PSI Series

Nom. flange size SAE (in.)	ISO (DN)	D1	L1	LA	LB	LX	LY	DB	Weight (steel) kg/piece	Order code*	PN (bar)	
											S	SS
1/2	13	13	16	46	58	17.5	38.1	9.0	0.30	5146-08	345	345
3/4	19	15	18	49	66	22.3	47.6	10.5	0.37	5146-12	345	345
1	25	18	19	53	71	26.2	52.4	10.5	0.54	5146-16	345	345
1 1/4	32	23	21	69	80	30.2	58.7	10.5	0.90	5146-20	276	276
1 1/2	38	28	24	77	95	35.7	69.9	13.5	1.03	5146-24	207	207
2	51	45	24	89	103	42.9	77.8	13.5	1.30	5146-32	207	207
2 1/2	64	58	25	101	116	50.8	88.9	13.5	1.45	5146-40	172	172
3	76	70	25	124	136	61.9	106.4	17.0	2.72	5146-48	138	138
3 1/2	89	85	25	136	152	69.9	120.7	17.0	2.90	5146-56	34	34
4	102	95	25	146	162	77.8	130.2	17.0	3.85	5146-64	34	34
5	127	110	25	180	184	92.1	152.4	17.0	4.20	5146-80	34	34

6000 PSI Series

1/2	13	13	16	46	58	18.2	40.5	9.0	0.30	5147-08	420	420
3/4	19	15	19	53	71	23.8	50.8	10.5	0.44	5147-12	420	420
1	25	22	24	66	80	27.8	57.2	13.5	0.73	5147-16	420	420
1 1/4	32	30	27	77	94	31.8	66.6	15.0	0.85	5147-20	420	420
1 1/2	38	35	30	89	103	36.5	79.3	17.0	1.61	5147-24	420	420
2	51	48	35	123	135	44.5	96.8	21.0	3.31	5147-32	420	420
2 1/2	64	55	45	150	166	58.7	123.8	25.0	4.50	5147-40	420	420
3	76	65	55	178	208	71.4	152.4	32.0	5.30	5147-48	420	420

*Please add suffix **RVS** after partnumber if stainless steel is required.

5148 / 5149 - SAE Closed counter flange

SAE Closed counter flange
(ISO 6162-1/-2)

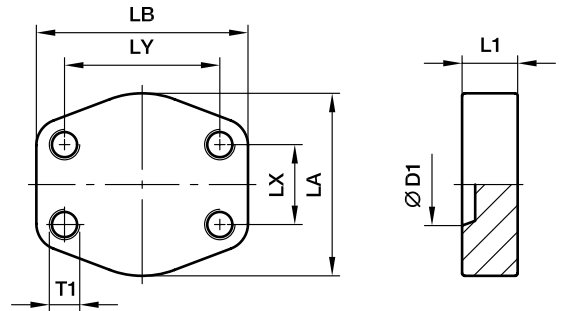

3000 PSI Series

Nom. flange size		D1	L1	LA	LB	LX	LY	Weight (steel) kg/piece	Order code*	PN (bar)	
SAE (in.)	ISO (DN)									S	SS
1/2	13	13	16	46	58	17.5	38.1	0.30	5148-08	345	345
3/4	19	15	18	49	66	22.3	47.6	0.37	5148-12	345	345
1	25	18	19	53	71	26.2	52.4	0.54	5148-16	345	345
1 1/4	32	23	21	69	80	30.2	58.7	0.90	5148-20	276	276
1 1/2	38	28	24	77	95	35.7	69.9	1.03	5148-24	207	207
2	51	45	24	89	103	42.9	77.8	1.20	5148-32	207	207
2 1/2	64	58	25	101	116	50.8	88.9	1.45	5148-40	172	172
3	76	70	25	124	136	61.9	106.4	2.72	5148-48	138	138
3 1/2	89	85	25	136	152	69.9	120.7	2.90	5148-56	34	34
4	102	95	25	146	162	77.8	130.2	3.85	5148-64	34	34
5	127	110	25	180	184	92.1	152.4	4.20	5148-80	34	34

6000 PSI Series

1/2	13	13	16	46	58	18.2	40.5	0.30	5149-08	420	420
3/4	19	15	19	53	71	23.8	50.8	0.44	5149-12	420	420
1	25	22	24	66	80	27.8	57.2	0.73	5149-16	420	420
1 1/4	32	30	27	77	94	31.8	66.6	0.85	5149-20	420	420
1 1/2	38	35	30	89	103	36.5	79.3	1.61	5149-24	420	420
2	51	48	35	123	135	44.5	96.8	3.31	5149-32	420	420
2 1/2	64	55	45	150	166	58.7	123.8	4.50	5149-40	420	420
3	76	65	55	178	208	71.4	152.4	5.30	5149-48	420	420

*Please add suffix **RVS** after partnumber if stainless steel is required.

5064 / 5065 - SAE Flange connector plate

ISO 6162-1/-2

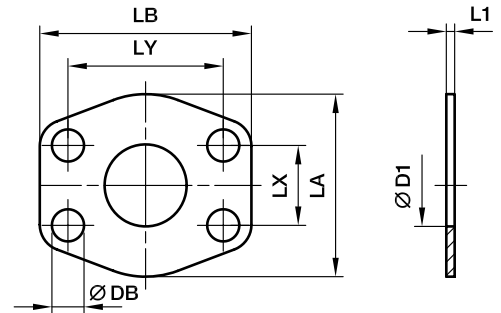

3000 PSI Series

Nom. flange size		D1	L1	LA	LB	LX	LY	DB	Weight (steel) kg/piece	Order code*	PN (bar)	
SAE (in.)	ISO (DN)										CF	SS
1/2	13	13	3	47	57	17.5	38.1	9.0	0.01	5064-08	345	345
3/4	19	19	3	49	66	22.3	47.6	11.0	0.01	5064-12	345	345
1	25	25	3	53	71	26.2	52.4	11.0	0.01	5064-16	345	345
1 1/4	32	32	3	69	80	30.2	58.7	11.5	0.02	5064-20	276	276
1 1/2	38	38	3	77	95	35.7	69.9	13.5	0.02	5064-24	207	207
2	51	51	3	89	103	42.9	77.8	13.5	0.03	5064-32	207	207
2 1/2	64	63	3	101	116	50.8	88.9	13.5	0.03	5064-40	172	172
3	76	73	4	124	136	61.9	106.4	17.0	0.04	5064-48	138	138
3 1/2	89	89	4	136	152	69.9	120.7	17.0	0.06	5064-56	34	34
4	102	99	4	146	162	77.8	130.2	17.0	0.08	5064-64	34	34
5	127	120	4	180	184	92.1	152.4	17.0	0.09	5064-80	34	34

6000 PSI Series

1/2	13	13	4	47	57	18.2	40.5	9.0	0.01	5065-08	420	420
3/4	19	17	4	53	71	23.8	50.8	11.0	0.01	5065-12	420	420
1	25	24	4	66	80	27.8	57.2	13.0	0.02	5065-16	420	420
1 1/4	32	31	4	77	94	31.8	66.6	15.0	0.03	5065-20	420	420
1 1/2	38	38	4	89	103	36.5	79.3	17.0	0.04	5065-24	420	420
2	51	51	4	123	135	44.5	96.8	21.0	0.05	5065-32	420	420
2 1/2	64	63	4	150	166	58.7	123.8	25.0	0.07	5065-40	420	420
3	76	73	4	178	208	71.4	152.4	32.0	0.08	5065-48	420	420

*Please add suffix **RVS** after partnumber if stainless steel is required.

5062 / 5063 - SAE Flange locking plate

ISO 6162-1/-2

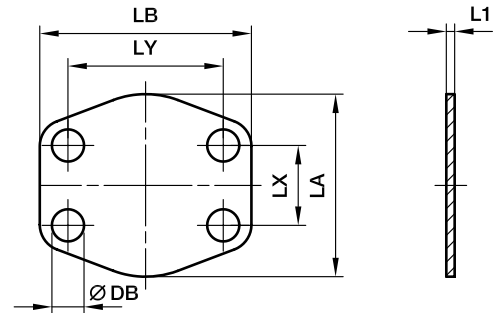

3000 PSI Series

Nom. flange size		L1	LA	LB	LX	LY	DB	Weight (steel) kg/piece	Order code*	PN (bar)	
SAE (in.)	ISO (DN)									CF	SS
1/2	13	3	47	57	17.5	38.1	9.0	0.02	5062-08	-	-
3/4	19	3	49	66	22.3	47.6	11.0	0.02	5062-12	-	-
1	25	3	53	71	26.2	52.4	11.0	0.02	5062-16	-	-
1 1/4	32	3	69	80	30.2	58.7	11.5	0.03	5062-20	-	-
1 1/2	38	3	77	95	35.7	69.9	13.5	0.03	5062-24	-	-
2	51	3	89	103	42.9	77.8	13.5	0.04	5062-32	-	-
2 1/2	64	3	101	116	50.8	89.9	13.5	0.04	5062-40	-	-
3	76	4	124	136	61.9	106.4	17.0	0.07	5062-48	-	-
3 1/2	89	4	136	152	69.9	102.7	17.0	0.07	5062-56	-	-
4	102	4	146	162	77.8	130.2	17.0	0.09	5062-64	-	-
5	127	4	180	184	92.1	152.4	17.0	0.10	5062-80	-	-

6000 PSI Series

1/2	13	4	47	57	18.2	40.5	9.0	0.02	5063-08	-	-
3/4	19	4	53	71	23.8	50.8	11.0	0.02	5063-12	-	-
1	25	4	66	80	27.8	57.1	13.0	0.03	5063-16	-	-
1 1/4	32	4	77	94	31.8	66.7	15.0	0.04	5063-20	-	-
1 1/2	38	4	89	103	36.5	79.4	17.0	0.05	5063-24	-	-
2	51	4	123	135	44.5	96.8	21.0	0.06	5063-32	-	-
2 1/2	64	4	150	166	58.7	123.8	25.0	0.08	5063-40	-	-
3	76	4	178	208	71.4	152.4	32.0	0.10	5063-48	-	-

*Please add suffix **RVS** after partnumber if stainless steel is required.

5060 / 5061 - Flange head plug flat

(ISO 6162-1/-2)

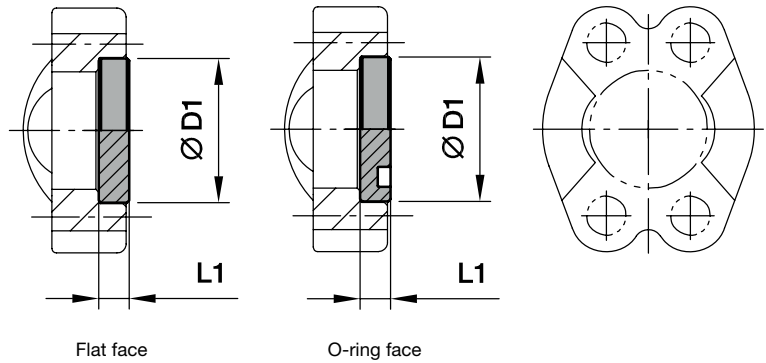

3000 PSI Series

Nom. flange size SAE (in.)	Ø D1	L1	Weight (steel) kg/piece	O-ring face Order code	PN (bar) CF
1/2	30.2	6.8	0.03	5060-08	210
3/4	38.1	6.8	0.05	5060-12	210
1	44.5	8.0	0.09	5060-16	210
1 1/4	50.8	8.0	0.12	5060-20	210
1 1/2	60.3	8.0	0.17	5060-24	160
2	71.4	9.6	0.29	5060-32	200
2 1/2	84.1	9.6	0.39	5060-40	–
3	101.6	9.6	0.58	5060-48	–
3 1/2	114.3	11.3	0.86	5060-56	–
4	127.0	11.3	1.02	5060-64	–
5	152.4	11.3	1.96	5060-80	–

6000 PSI Series

1/2	31.8	7.8	0.04	5061-08	250
3/4	41.3	8.8	0.09	5061-12	250
1	47.6	9.5	0.13	5061-16	250
1 1/4	54.0	10.3	0.18	5061-20	250
1 1/2	63.5	12.6	0.30	5061-24	250
2	79.4	12.6	0.48	5061-32	250
2 1/2	108.0	21.2	1.26	5061-40	–
3	132.0	26.5	2.31	5061-48	–

Flange head plug in stainless steel on request.

5112 / 5113 - SAE 4 bolt flange with test point port

SAE Flange with test point port
(ISO 6162-1/-2)

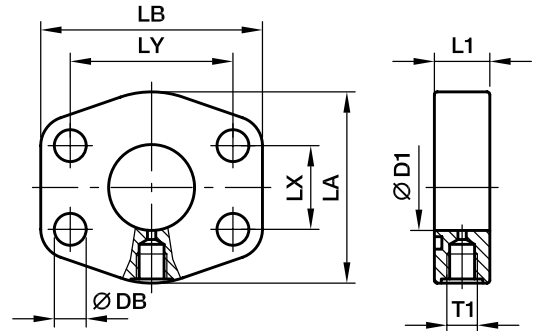

3000 PSI Series

Nom. flange size SAE (in.)	ISO (DN)	T1	D1	L1	LA	LB	LX	LY	DB	Weight (steel) kg/piece	Order code*	PN (bar ¹)	
												S	SS
1	25	G 1/4	25	22	53	71	26.2	52.4	11.0	0.65	5112-16	348	348
1 1/4	32	G 1/4	31	20	69	80	30.2	58.7	11.5	0.75	5112-20	278	278
1 1/2	38	G 1/4	38	25	77	94	35.7	69.9	13.5	0.80	5112-24	210	210
2	51	G 1/4	50	25	89	103	42.9	77.8	13.5	1.25	5112-32	210	210
2 1/2	64	G 1/4	63	25	101	115	50.8	88.9	13.5	1.75	5112-40	175	175
3	76	G 1/4	73	27	124	135	61.9	106.4	17.0	2.25	5112-48	138	138
3 1/2	89	G 1/4	89	27	136	152	61.9	120.7	17.0	3.00	5112-56	35	35
4	102	G 1/4	99	26	146	162	77.8	130.2	17.0	4.25	5112-64	35	35
5	127	G 1/4	120	23	180	184	92.1	152.4	17.0	5.75	5112-80	35	35

6000 PSI Series

1	25	G 1/4	25	22	69	80	27.8	57.2	13.0	0.65	5113-16	420	420
1 1/4	32	G 1/4	31	26	77	94	31.8	66.6	15.0	0.75	5113-20	420	420
1 1/2	38	G 1/4	38	30	89	106	36.5	79.3	17.0	0.95	5113-24	420	420
2	51	G 1/4	50	36	116	135	44.5	96.8	21.0	1.25	5113-32	420	420
2 1/2	64	G 1/4	63	45	150	166	58.7	123.8	25.0	1.75	5113-40	420	420
3	76	G 1/4	73	55	178	208	71.4	152.4	32.0	2.25	5113-48	420	420

*Please add suffix **RVS** after partnumber if stainless steel is required.

PRF - SAE Straight reducing flange adapter

ISO 6162-1/-2

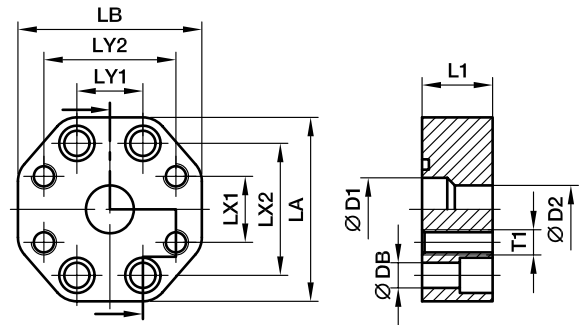

3000 PSI Series

Nom. flange size		D1	D2	L1	LA	LB	LX1	LX2	LY1	LY2	DB	T1	Weight (steel) kg/piece	Order code	PN (bar) S
SAE (in.)	ISO (DN)														
1x1	25/25	25	25	28	73	73	26.2	52.4	26.2	52.4	11	M10	1.10	PRF102/102	210
1x3/4	25/19	25	19	28	73	73	22.3	52.4	26.2	47.6	11	M10	1.15	PRF102/100	210
1 1/4x1 1/4	32/32	30	30	28	80	80	30.2	58.7	30.2	58.7	11	M10	1.55	PRF104/104	210
1 1/4x1	32/25	30	25	28	80	71	26.2	58.7	30.2	52.4	11	M10	1.55	PRF104/102	210
1 1/2x1 1/2	38/38	38	38	32	94	94	35.7	69.9	35.7	69.9	13	M12	2.25	PRF106/106	210
1 1/2x1 1/4	38/32	38	30	32	94	80	30.2	69.9	35.7	58.7	13	M10	2.40	PRF106/104	210
2x2	51/51	50	50	33	103	103	42.9	77.8	42.9	77.8	13	M12	3.00	PRF108/108	210
2x1 1/2	51/38	50	38	33	103	94	35.7	77.8	42.9	70.0	13	M12	3.15	PRF108/106	210
2 1/2x2 1/2	64/64	63	63	33	115	115	50.8	88.9	50.8	88.9	13	M12	3.85	PRF110/110	175
2 1/2x2	64/51	63	50	33	115	103	42.9	88.9	50.8	77.8	13	M12	3.95	PRF110/108	175
3x3	76/76	73	73	36	135	135	61.9	106.4	61.9	106.4	17	M16	4.25	PRF112/112	138
3x2 1/2	76/64	73	63	36	135	115	50.8	106.4	61.9	89.0	17	M12	4.45	PRF112/110	138

6000 PSI Series

3/4x3/4	19/19	19	19	28	71	71	23.8	50.8	23.8	50.8	11	M10	0.80	PRF402/402	420
1x1	25/25	25	25	33	80	80	27.8	57.2	27.8	57.2	13	M12	1.10	PRF403/403	420
1x3/4	25/19	25	19	33	80	71	23.8	57.2	27.8	50.8	13	M10	1.10	PRF403/402	420
1 1/4x1 1/4	32/32	30	30	33	94	94	31.8	66.6	31.8	66.6	15	M14	1.40	PRF404/404	420
1 1/4x1	32/25	30	25	33	94	80	27.8	66.6	31.8	57.2	15	M12	1.60	PRF404/403	420
1 1/2x1 1/2	38/38	38	38	48	106	106	36.5	79.3	36.5	79.3	17	M16	3.30	PRF405/405	420
1 1/2x1 1/4	38/32	38	30	48	106	94	31.8	79.3	36.5	66.6	17	M14	3.60	PRF405/404	420
2x2	51/51	50	50	48	135	135	44.5	96.8	44.5	96.8	21	M20	5.00	PRF406/406	420
2x1 1/2	51/38	50	38	48	135	106	36.5	96.8	44.5	79.3	21	M16	5.25	PRF406/405	420
2 1/2x2	64/51	63	50	53	166	150	44.5	123.8	58.7	96.8	25	M20	6.50	PRF408/406	420
3x2	76/51	73	50	58	208	178	44.5	152.4	71.4	96.8	31	M20	7.50	PRF410/406	420

*Please add suffix **RVS** after partnumber if stainless steel is required.

BFG - Gear pump flange straight

Hydraulic flange / EO 24° cone end

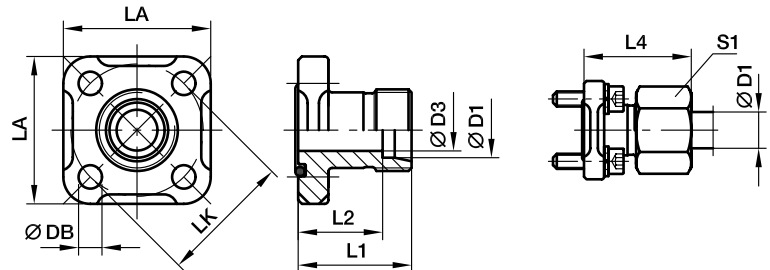

BFG - Straight flange connection EO 24° cone end

LK	Ø D1	D3	L1	L2	L4	LA	S1	DB	Screws	O-ring	Weight (steel) kg/piece	Order code	PN (bar)
									(metr.)				CF
35	10L	8	30	23.0	39.0	39	19	6.4	M 06×22	20×2.5	0.15	BFG10L/LK35	315
35	12L	10	30	23.0	39.0	39	22	6.4	M 06×22	20×2.5	0.16	BFG12L/LK35	315
35	15L	12	30	23.0	38.0	39	27	6.4	M 06×22	20×2.5	0.19	BFG15L/LK35	250
35	16S	12	30	21.5	39.5	39	30	6.4	M 06×22	20×2.5	0.21	BFG16S/LK35	315
40	15L	12	35	28.0	43.0	42	27	6.4	M 06×22	26×2.5	0.17	BFG15L/LK40	100
40	18L	15	35	27.5	44.0	42	32	6.4	M 06×22	26×2.5	0.22	BFG18L/LK40	100
40	22L	19	35	27.5	44.5	42	36	6.4	M 06×22	26×2.5	0.24	BFG22L/LK40	100
40	28L	24	35	27.5	44.5	42	41	6.4	M 06×22	26×2.5	0.28	BFG28L/LK40	100
55	20S	16	50	39.5	61.0	57	36	8.4	M 08×25	32×2.5	0.35	BFG20S/LK55	250

BFW - Gear pump flange 90° elbow

Hydraulic flange / EO 24° cone end

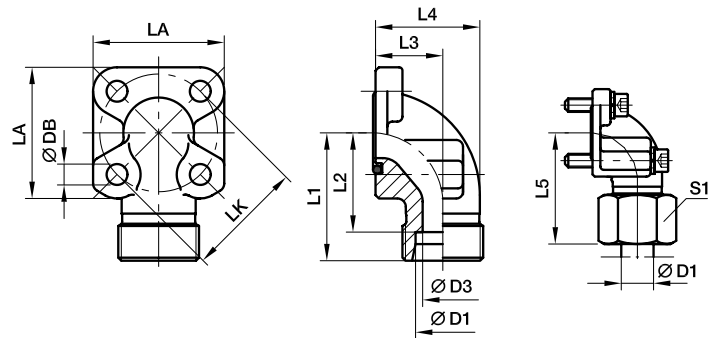

BFW - 90° Flange connection EO 24° cone end

LK	Ø	D1	D3	L1	L2	L3	L4	L5	LA	S1	DB	Screws		O-ring	Weight (steel) kg/piece	Order code	PN (bar)
												2 pieces (metr.)	2 pieces (metr.)				
35	10L	8	38	31.0	16.5	26.5	47.0	40	19	6.4	M 06×22	M 06×35	20×2.5	0.23	BFW10L/LK35	315	
35	12L	10	38	31.0	16.5	26.5	47.0	40	22	6.4	M 06×22	M 06×35	20×2.5	0.26	BFW12L/LK35	315	
35	15L	12	38	31.0	16.5	26.5	46.0	40	27	6.4	M 06×22	M 06×35	20×2.5	0.38	BFW15L/LK35	315	
35	16S	12	38	29.5	20.0	31.0	48.0	40	30	6.4	M 06×22	M 06×40	20×2.5	0.55	BFW16S/LK35	315	
35	20S	16	45	34.5	25.0	38.0	56.0	40	36	6.4	M 06×22	M 06×45	20×2.5	0.65	BFW20S/LK35	315	
40	15L	12	38	31.0	22.5	36.5	46.0	42	27	6.4	M 06×22	M 06×22	26×2.5	0.29	BFW15L/LK40	100	
40	18L	15	38	30.5	22.5	36.5	47.0	42	32	6.4	M 06×22	M 06×22	26×2.5	0.70	BFW18L/LK40	100	
40	22L	19	38	30.5	22.5	36.5	47.5	42	36	6.4	M 06×22	M 06×22	26×2.5	0.36	BFW22L/LK40	100	
40	28L	22	40	32.5	28.0	43.0	49.0	42	41	6.4	M 06×20	M 06×50	26×2.5	0.82	BFW28L/LK40	100	
40	35L	31	41	30.5	32.0	55.0	52.0	42	50	6.4	M 06×22	M 06×60	26×2.5	0.22	BFW35L/LK40	100	
40	20S	16	40	29.5	22.5	35.5	50.0	42	36	6.4	M 06×22	M 06×45	26×2.5	0.23	BFW20S/LK40	250	
55	35L	31	49	38.5	32.0	51.5	62.0	58	50	8.4	M 08×25	M 08×60	32×2.5	0.27	BFW35L/LK55	250	
55	42L	38	49	38.0	40.0	64.5	61.0	58	60	8.4	M 08×25	M 08×70	32×2.5	0.41	BFW42L/LK55	250	
55	20S	17	45	34.5	24.0	38.0	56.0	58	36	8.4	M 08×25	M 08×50	32×2.5	0.94	BFW20S/LK55	250	
55	25S	20	49	37.0	30.0	46.0	61.0	58	46	8.4	M 08×25	M 08×55	32×2.5	0.80	BFW25S/LK55	250	
55	30S	26	49	35.5	32.0	50.0	62.0	58	50	8.4	M 08×25	M 08×50	32×2.5	0.20	BFW30S/LK55	250	

BFW3 - Gear pump flange 90° elbow 3 holes

Hydraulic flange / EO 24° cone end

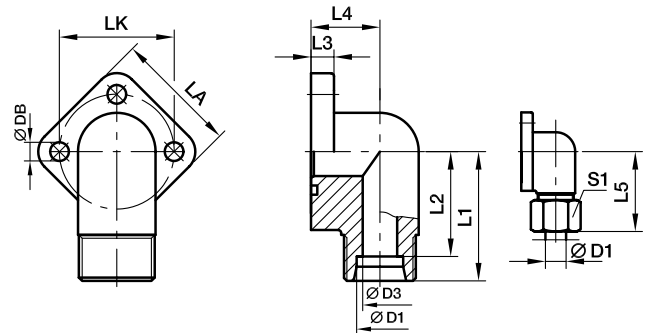

BFW-3 - 90° Flange connection EO 24° cone end

LK	Ø		L1	L2	L3	L4	L5	LA	S1	DB	Screws	O-ring	Weight (steel) kg/piece	Order code	PN (bar)
	D1	D3									(metr.)				CF
30	12L	10	37	30.0	10	37.5	46	38	22	6.4	M 06×22	16×2.5	0.13	BFW3-12L/LK30	250
30	15L	12	37	30.0	10	37.5	47	38	27	6.4	M 06×22	16×2.5	0.14	BFW3-15L/LK30	250
30	18L	15	37	30.0	10	37.5	47	38	32	6.4	M 06×22	16×2.5	0.17	BFW3-18L/LK30	160
40	22L	19	43	35.5	14	41.0	53	48	36	8.4	M 08×30	24×2.5	0.29	BFW3-22L/LK40	160
40	28L	24	43	35.5	14	41.0	53	48	41	8.4	M 08×30	24×2.5	0.40	BFW3-28L/LK40	160

BFW-G - Gear pump flange 90° elbow

Hydraulic flange / BSPP 60° cone end

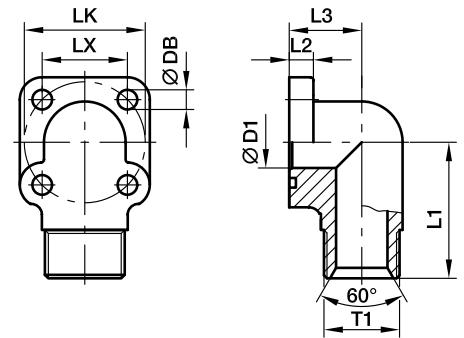

BFW-G - 90° BSPP 60° cone end

LK	T1	D1	L1	L2	L3	LX	DB	Screws		O-ring	Weight (steel) kg/piece	Order code	PN (bar) CF
								2 pieces (metr.)	2 pieces (metr.)				
35	G 3/8	10	40	8	20.0	24.8	6.5	M 06×20	M 06×35	18.72×2.62	0.22	BFW-G38/LK35	315
35	G 1/2	12	40	8	20.0	24.8	6.5	M 06×20	M 06×35	18.72×2.62	0.24	BFW-G12/LK35	315
35	G 3/4	15	40	8	20.0	24.8	6.5	M 06×20	M 06×40	18.72×2.62	0.26	BFW-G34/LK35	315
40	G 3/8	10	40	8	22.5	28.2	6.5	M 06×20	M 06×40	25.07×2.62	0.30	BFW-G38/LK40	250
40	G 1/2	12	40	8	22.5	28.2	6.5	M 06×20	M 06×40	25.07×2.62	0.32	BFW-G12/LK40	250
40	G 3/4	17	40	8	22.5	28.2	6.5	M 06×20	M 06×40	25.07×2.62	0.34	BFW-G34/LK40	250
40	G 1	19	40	8	28.0	28.2	6.5	M 06×20	M 06×50	25.07×2.62	0.36	BFW-G1/LK40	250
55	G 1/2	12	49	12	24.0	38.8	8.5	M 08×25	M 08×45	31.42×2.62	0.35	BFW-G12/LK55	250
55	G 3/4	17	46	12	24.0	38.8	8.5	M 08×25	M 08×60	31.42×2.62	0.40	BFW-G34/LK55	250
55	G 1	22	49	12	31.0	38.8	8.5	M 08×25	M 08×70	31.42×2.62	0.45	BFW-G1/LK55	250

BFW-GI - Gear pump flange 90° elbow

Hydraulic flange / Female BSPP thread

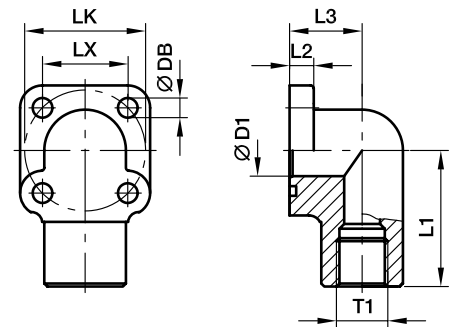

BFW-GI - 90° Female BSPP thread

LK	T1	D1	L1	L2	L3	LX	DB	Screws		O-ring	Weight (steel) kg/piece	Order code	PN (bar) CF
								2 pieces (metr.)	2 pieces (metr.)				
35	G 3/8	10	40	8	20.0	24.8	6.5	M 06×20	M 06×35	18.72×2.62	0.22	BFW-GI38/LK35	315
35	G 1/2	12	40	8	20.0	24.8	6.5	M 06×20	M 06×35	18.72×2.62	0.24	BFW-GI12/LK35	315
40	G 3/8	10	40	8	22.5	28.2	6.5	M 06×20	M 06×40	25.07×2.62	0.30	BFW-GI38/LK40	250
40	G 1/2	12	40	8	22.5	28.2	6.5	M 06×20	M 06×40	25.07×2.62	0.32	BFW-GI12/LK40	250
40	G 3/4	17	40	8	22.5	28.2	6.5	M 06×20	M 06×40	25.07×2.62	0.34	BFW-GI34/LK40	250
55	G 1/2	12	49	12	24.0	38.8	8.5	M 08×25	M 08×45	31.42×2.62	0.35	BFW-GI12/LK55	250
55	G 3/4	17	46	12	24.0	38.8	8.5	M 08×25	M 08×60	31.42×2.62	0.40	BFW-GI34/LK55	250
55	G 1	22	49	12	31.0	38.8	8.5	M 08×25	M 08×70	31.42×2.62	0.45	BFW-G I1/LK55	250

BFW3-G - Gear pump flange 90° elbow 3 holes

Hydraulic flange / Female BSPP thread

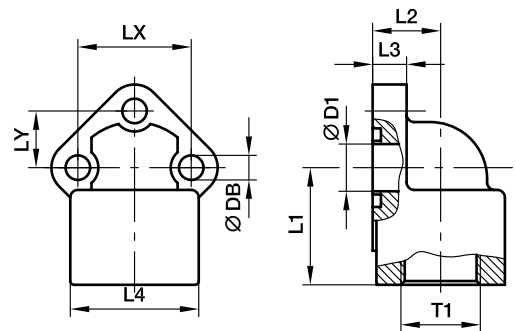

PWDS - Female BSPP thread

Pump size	LK	T1	D1	L1	L2	L3	L4	LX	LY	DB	Screws (metr.)	O-ring	Weight (steel) kg/piece	Order code	PN (bar) CF
0.5	26.0	3/8	11	28	17	9.0	30	26.0	13.0	5.5	M 05×18	15.60×1.78	0.16	BFW3-G38/LK26	315
0.5	26.0	1/2	11	28	17	9.0	30	26.0	13.0	5.5	M 05×18	15.60×1.78	0.15	BFW3-G12/LK26	315
1.0	30.0	3/8	12	30	17	9.0	30	30.0	15.0	6.5	M 06×20	15.88×2.62	0.16	BFW3-G38/LK30	315
1.0	30.0	1/2	12	30	17	9.0	30	30.0	15.0	6.5	M 06×20	15.88×2.62	0.15	BFW3-G12/LK30	315
2.0	40.0	1/2	18	36	23	11.5	36	40.0	20.0	8.5	M 08×25	23.81×2.62	0.33	BFW3-G12/LK40	315
2.0	40.0	3/4	18	36	23	11.5	36	40.0	20.0	8.5	M 08×25	23.81×2.62	0.31	BFW3-G34/LK40	315
3.0	51.0	3/4	24	46	26	13.0	45	51.0	25.5	10.5	M 10×30	29.75×3.53	0.57	BFW3-G34/LK51	315
3.0	51.0	1	24	46	26	13.0	45	51.0	25.5	10.5	M 10×30	29.75×3.53	0.52	BFW3-G1/LK51	315
3B	56.0	3/4	24	46	26	13.0	45	56.0	28.0	10.5	M 10×30	29.75×3.53	0.57	BFW3-G34/LK56	315
3B	56.0	1	24	46	26	13.0	45	56.0	28.0	10.5	M 10×30	29.75×3.53	0.52	BFW3-G1/LK56	315
3.5	62.0	1 1/4	31	55	35	14.0	55	62.0	31.0	11.0	M 10×30	37.69×3.53	0.74	BFW3-G114/LK62	315
3.5	62.0	1	25	55	35	14.0	55	62.0	31.0	11.0	M 10×30	37.69×3.53	0.73	BFW3-G1/LK62	315
3.5	62.0	1 1/4	31	55	35	14.0	55	62.0	31.0	13.0	M 12×35	37.69×3.53	0.74	BFW3-G114/LK62/12	315
3.5	62.0	1	25	55	35	14.0	55	62.0	31.0	13.0	M 12×35	37.69×3.53	0.73	BFW3-G1/LK62/12	315
4.0	72.5	1 1/2	38	58	38	15.0	62	72.5	36.2	13.0	M 12×35	47.22×3.53	0.95	BFW3-G112/LK72.5	315
4.0	72.5	1 1/4	31	58	38	15.0	62	72.5	36.2	13.0	M 12×35	47.22×3.53	0.93	BFW3-G114/LK72.5	315

PWDS-G - Gear pump flange 90° elbow 4 holes – aluminium

Hydraulic flange / Female BSPP thread

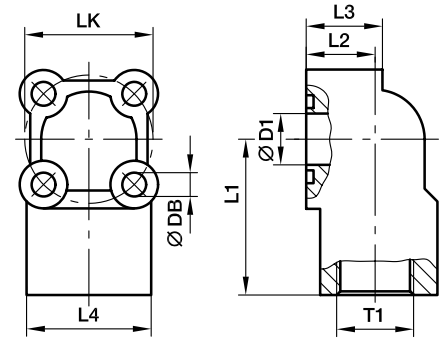

PWDS-G - 90° Female BSPP thread

LK	T1	D1	L1	L2	L3	L4	DB	Screws		O-ring	Weight (steel) kg/piece	Order code	PN (bar) A
								2 pieces (metr.)	2 pieces (metr.)				
30	G 3/8	11.5	39.0	18	20	33	6.5	M 06×30	M 06×40	15.88×2.62	0.09	PWDS-G38/LK30	180
30	G 1/2	11.5	39.0	18	20	33	6.5	M 06×30	M 06×40	15.88×2.62	0.09	PWDS-G12/LK30	180
35	G 3/8	14.0	42.5	18	20	34	6.5	M 06×30	M 06×40	18.72×2.62	0.11	PWDS-G38/LK35	180
35	G 1/2	14.0	42.5	18	20	34	6.5	M 06×30	M 06×40	18.72×2.62	0.11	PWDS-G12/LK35	180
40	G 1/2	18.0	47.5	24	28	41	6.5	M 06×40	M 06×50	22.22×2.62	0.18	PWDS-G12/LK40	180
40	G 3/4	18.0	47.5	24	28	41	6.5	M 06×40	M 06×50	22.22×2.62	0.18	PWDS-G34/LK40	180
55	G 3/4	24.5	54.0	29	31	49	8.5	M 08×45	M 08×60	29.75×3.53	0.31	PWDS-G34/LK55	180
55	G 1	24.5	54.0	29	31	49	8.5	M 08×45	M 08×60	29.75×3.53	0.30	PWDS-G1/LK55	180

Flanges

PWDA - Gear pump flange 90° elbow 3 holes – aluminium

Hydraulic flange / Female BSPP thread (ISO 1179-1)

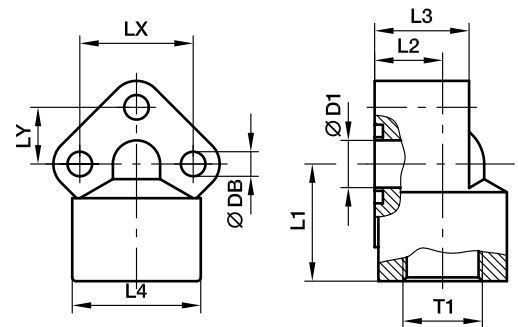

PWDA - 90° Female BSPP thread

Pump size	LK	T1	D1	L1	L2	L3	L4	LX	LY	DB	Screws (metr.)	O-ring	Weight (steel) kg/piece	Order code	PN (bar) A
0.5	26	G 3/8	10.0	31	18.0	25	31	26	13.0	5.5	M 05×35	14.00×1.78	0.06	PWDA-05/38	180
0.5	26	G 1/2	10.0	31	18.0	25	31	26	13.0	5.5	M 05×35	14.00×1.78	0.06	PWDA-05/12	180
1.0	30	G 3/8	12.5	31	18.0	26	34	30	15.0	6.5	M 06×35	15.88×2.62	0.08	PWDA-1/38	180
1.0	30	G 1/2	12.5	31	18.0	26	34	30	15.0	6.5	M 06×35	15.88×2.62	0.08	PWDA-1/12	180
2.0	40	G 1/2	18.0	40	21.5	31	42	40	20.0	8.5	M 08×45	22.22×2.62	0.15	PWDA-2/12	180
2.0	40	G 3/4	18.0	40	21.5	31	42	40	20.0	8.5	M 08×45	22.22×2.62	0.15	PWDA-2/34	180
3.0*	51	G 3/4	24.5	46	26.0	42	49	56	25.5–28	11.0	M 10×60	29.75×3.53	0.32	PWDA-3/34	180
3.0*	51	G 1	24.5	46	26.0	42	49	56	25.5–28	11.0	M 10×60	29.75×3.53	0.32	PWDA-3/100	180



EO-Tubes for fitting systems (Industrial- and Mobile-Applications)

Seamless EO steel tubes | Material E235+N / St.37.4 (1.0308)

Acc. to DIN EN 10305-4

1. DIN 2413 I: Tubes with a diameter of OD/ID>2 are calculated for static stress in accordance with DIN 2413 III but with K=yield strength.
2. Evaluated in Parker Lab and Test Field. () = Burst pressure (B.P.) acc. to Faupel-von-Mises

Material E235+N / St.37.4 (1.0308)		d _a Outer-Ø (mm)	Outer-Ø Tolerance (mm)	s Wall- thickness (mm)	d _i Inner-Ø (mm)	Design pressure			Weight kg/m
Surface						1 DIN 2413 I static PN bar	DIN 2413 III dynamic PN bar	2 Burst pressure bar	
Phosphated and oiled	Cr(VI)- free								
Order code									
R04X0.5	R04X0.5CF	04		0.50	3.0	313	273	1160	0.047
	R04X0.75CF	04	±0.08	0.75	2.5	470	391	1820	0.063
R04X1	R04X1CF	04		1.00	2.0	627	500	2700	0.074
	R05X1CF	05	±0.08	1.00	3.0	501	414	2120	0.099
	R06X0.75CF	06		0.75	4.5	333	288	1150	0.103
R06X1	R06X1CF	06	±0.08	1.00	4.0	444	372	1650	0.123
R06X1.5	R06X1.5CF	06		1.50	3.0	666	526	2550	0.166
	R06X2CF	06		2.00	2.0	692	662	>3500	0.197
R06X2.25	R06X2.25CF	06		2.25	1.5	757	725	>3500	0.208
R08X1	R08X1CF	08		1.00	6.0	333	288	1175	0.173
R08X1.5	R08X1.5CF	08	±0.08	1.50	5.0	499	412	1925	0.240
R08X2	R08X2CF	08		2.00	4.0	666	526	2500	0.296
	R08X2.5CF	08		2.50	3.0	658	630	2650	0.339
R10X1	R10X1CF	10		1.00	8.0	282	248	900	0.222
R10X1.5	R10X1.5CF	10	±0.08	1.50	7.0	423	357	1450	0.314
R10X2	R10X2CF	10		2.00	6.0	564	458	2025	0.395
R10X2.5	R10X2.5CF	10		2.50	5.0	705	551	2675	0.462
	R10X3CF	10		3.00	4.0	666	638	>3500	0.518
R12X1	R12X1CF	12		1.00	10.0	235	209	750	0.271
R12X1.5	R12X1.5CF	12	±0.08	1.50	9.0	353	303	1150	0.388
R12X2	R12X2CF	12		2.00	8.0	470	391	1600	0.493
	R12X2.5CF	12		2.50	7.0	588	474	2025	0.586
	R12X3CF	12		3.00	6.0	705	551	2600	0.666
	R12X3.5CF	12		3.50	5.0	651	624	(3109)	0.734
R14X2	R14X2CF	14	±0.08	2.00	10.0	403	342	1325	0.592
R14X2.5	R14X2.5CF	14		2.50	9.0	504	415	1650	0.709
	R14X3CF	14		3.00	8.0	604	485	2200	0.814
R15X1	R15X1CF	15		1.00	13.0	188	170	575	0.345
R15X1.5	R15X1.5CF	15	±0.08	1.50	12.0	282	248	950	0.499
R15X2	R15X2CF	15		2.00	11.0	376	321	1275	0.641
R16X1.5	R16X1.5CF	16	±0.08	1.50	13.0	264	233	850	0.536
R16X2	R16X2CF	16		2.00	12.0	353	303	1175	0.691
R16X2.5	R16X2.5CF	16		2.50	11.0	441	370	1500	0.832
R16X3	R16X3CF	16		3.00	10.0	529	433	1850	0.962
R18X1	R18X1CF	18		1.00	16.0	157	143	450	0.419
R18X1.5	R18X1.5CF	18	±0.08	1.50	15.0	235	209	700	0.610
R18X2	R18X2CF	18		2.00	14.0	313	273	975	0.789
R18X2.5	R18X2.5CF	18		2.50	13.0	392	333	1300	0.956
	R18X3CF	18		3.00	12.0	470	391	1575	1.111

Surface finish:

- Tubes with I.D. 1.5-5 mm: outside and inside oiled.
- Tubes from 6 mm I.D.: outside and inside phosphated and oiled.

• Cr(VI)-free:

These dimensions are externally thick coat passivated (thickness of coat 8-12µm), inside oiled.

EO-Tubes for fitting systems (Industrial- and Mobile-Applications)

Seamless EO steel tubes (continued) | Material E235+N / St.37.4 (1.0308)

Acc. to DIN EN 10305-4

1. DIN 2413 I: Tubes with a diameter of OD/ID>2 are calculated for static stress in accordance with DIN 2413 III but with K=yield strength.
2. Evaluated in Parker Lab and Test Field.

Material E235+N / St.37.4 (1.0308)		d _a Outer-Ø (mm)	Outer-Ø Tolerance (mm)	s Wall- thickness (mm)	d _i Inner-Ø (mm)	Design pressure			Weight kg/m
Surface						1 DIN 2413 I static PN bar	DIN 2413 III dynamic PN bar	2 Burst pressure bar	
Phosphated and oiled	Cr(VI)- free								
Order code									
R20X2 R20X2.5 R20X3	R20X1.5CF	20	±0.08	1.50	17.0	212	190	675	0.684
	R20X2CF	20		2.00	16.0	282	248	900	0.888
	R20X2.5CF	20		2.50	15.0	353	303	1100	1.079
	R20X3CF	20		3.00	14.0	423	357	1400	1.258
	R20X3.5CF	20		3.50	13.0	494	408	1650	1.424
	R20X4CF	20		4.00	12.0	564	458	2000	1.578
R22X1.5 R22X2 R22X2.5	R22X1.5CF	22	±0.08	1.50	19.0	192	173	550	0.758
	R22X2CF	22		2.00	18.0	256	227	775	0.986
	R22X2.5CF	22		2.50	17.0	320	278	1025	1.202
	R22X3CF	22		3.00	16.0	385	328	1175	1.406
R25X2 R25X2.5 R25X3 R25X4	R25X2CF	25	±0.08	2.00	21.0	226	201	725	1.134
	R25X2.5CF	25		2.50	20.0	282	248	850	1.387
	R25X3CF	25		3.00	19.0	338	292	1025	1.628
	R25X4CF	25		4.00	17.0	451	378	1500	2.072
	R25X4.5CF	25		4.50	16.0	508	418	1625	2.275
R28X1.5 R28X2 R28X2.5 R28X3	R28X1.5CF	28	±0.08	1.50	25.0	151	138	425	0.980
	R28X2CF	28		2.00	24.0	201	181	600	1.282
	R28X2.5CF	28		2.50	23.0	252	223	750	1.572
	R28X3CF	28		3.00	22.0	302	264	900	1.850
R30X2.5 R30X3 R30X4 R30X5	R30X2CF	30	±0.08	2.00	26.0	188	170	575	1.381
	R30X2.5CF	30		2.50	25.0	235	209	725	1.695
	R30X3CF	30		3.00	24.0	282	248	850	1.998
	R30X4CF	30		4.00	22.0	376	321	1175	2.565
	R30X5CF	30		5.00	20.0	470	391	1600	3.083
R35X2 R35X2.5 R35X3	R35X2CF	35	±0.15	2.00	31.0	161	147	450	1.628
	R35X2.5CF	35		2.50	30.0	201	181	600	2.004
	R35X3CF	35		3.00	29.0	242	215	700	2.367
	R35X4CF	35		4.00	27.0	322	280	960	3.058
R38X3 R38X4 R38X5	R38X2.5CF	38	±0.15	2.50	33.0	186	168	550	2.189
	R38X3CF	38		3.00	32.0	223	199	675	2.589
	R38X4CF	38		4.00	30.0	297	260	900	3.354
	R38X5CF	38		5.00	28.0	371	318	1150	4.069
	R38X6CF	38		6.00	26.0	445	373	1425	4.735
	R38X7CF	38		7.00	24.0	519	427	1700	5.352
R42X2 R42X3 R42X4	R42X2CF	42	±0.20	2.00	38.0	134	123	375	1.973
	R42X3CF	42		3.00	36.0	201	181	575	2.885
	R42X4CF	42		4.00	34.0	269	237	850	3.749

Other sizes on request!

EO-Tubes for fitting systems (Industrial- and Mobile-Applications)

Seamless EO steel tubes | Material E355+N / St.52.4 (1.0580)

Acc. to DIN EN 10305-4

- DIN 2413 I: Tubes with a diameter of OD/ID>2 are calculated for static stress in accordance with DIN 2413 III but with K=yield strength.
- Burst pressure (B.P.) acc. to Faupel-von-Mises

Material E355+N / St.52.4 (1.0580)		d _a Outer-Ø (mm)	Outer-Ø Tolerance (mm)	s Wall- thickness (mm)	d _i Inner-Ø (mm)	Design pressure		2 Burst pressure bar	Weight kg/m
Surface						1 DIN 2413 I static PN bar	DIN 2413 III dynamic PN bar		
Phosphated and oiled	Cr(VI)- free								
Order code									
	R10X2ST52CF	10	±0.08	2.00	6.0	852	539	2671	0.395
	R12X1.5ST52CF	12	±0.08	1.50	9.0	533	357	1504	0.388
	R12X2ST52CF	12		2.00	8.0	710	461	2120	0.493
	R15X1.5ST52CF	15	±0.08	1.50	12.0	426	292	1167	0.499
	R15X2ST52CF	15		2.00	11.0	568	379	1622	0.641
R16X2ST52	R16X1.5ST52CF	16	±0.08	1.50	13.0	399	275	1086	0.536
	R16X2ST52CF	16		2.00	12.0	533	357	1504	0.691
	R16X2.5ST52CF	16		2.50	11.0	666	436	1959	0.832
	R18X1.5ST52CF	18	±0.08	1.50	15.0	355	247	953	0.610
	R18X2ST52CF	18		2.00	14.0	473	321	1314	0.789
	R20X2ST52CF	20	±0.08	2.00	16.0	426	292	1167	0.888
	R20X2.5ST52CF	20		2.50	15.0	533	357	1504	1.079
	R20X3ST52CF	20		3.00	14.0	639	420	185	1.258
	R22X1.5ST52CF	22	±0.08	1.50	19.0	290	204	767	0.758
	R22X2ST52CF	22		2.00	18.0	387	267	1049	0.986
R25X3ST52	R25X2.5ST52CF	25	±0.08	2.50	20.0	426	292	1167	1.387
	R25X3ST52CF	25		3.00	19.0	511	344	1435	1.628
	R25X4ST52CF	25		4.00	17.0	682	445	2016	2.072
	R28X2ST52CF	28	±0.08	2.00	24.0	304	213	806	1.282
R30X3ST52	R30X3ST52CF	30	±0.08	3.00	24.0	426	292	1167	1.998
	R30X4ST52CF	30		4.00	22.0	568	379	1622	2.565
	R30X5ST52CF	30		5.00	20.0	710	461	2120	3.083
	R35X3ST52CF	35	±0.15	3.00	29.0	365	253	983	2.367
R38X4ST52	R38X3ST52CF	38	±0.15	3.00	32.0	336	234	899	2.589
	R38X4ST52CF	38		4.00	30.0	448	306	1236	3.354
	R38X5ST52CF	38		5.00	28.0	561	374	1597	4.069
	R38X6ST52CF	38		6.00	26.0	673	440	1984	4.735
	R42X3ST52CF	42	±0.20	3.00	36.0	304	213	806	2.885
	R42X4ST52CF	42		4.00	34.0	406	279	1105	3.748
	R42X5ST52CF	42		5.00	32.0	507	342	1422	4.562

Surface finish:

- Tubes with I.D. 1.5-5 mm: outside and inside oiled.
- Tubes from 6 mm I.D.: outside and inside phosphated and oiled.

• Cr(VI)-free:

These dimensions are externally thick coat passivated (thickness of coat 8-12µm), inside oiled.

Other sizes on request!

EO-Tubes for fitting systems (Industrial- and Mobile-Applications)

Seamless EO stainless steel tubes | Material 316Ti (1.4571)

Acc. to DIN EN 10216-5, DIN EN 10305-1

1. DIN 2413 I: Tubes with a diameter of OD/ID>2 are calculated for static stress in accordance with DIN 2413 III but with K=yield strength.
2. Evaluated in Parker Lab and Test Field. () = Burst pressure (B.P.) acc. to Faupel-von-Mises

Material 316Ti (1.4571)	d _a Outer-Ø (mm)	Outer-Ø Tolerance (mm)	s Wall- thickness (mm)	d _i Inner-Ø (mm)	Design pressure			Weight kg/m
					1	DIN 2413 III	2	
					DIN 2413 I static	dynamic PN bar	Burst pressure bar	
R04X171	04	±0.08	1.0	2.0	735	539	(2961)	0.075
R06X171	06	±0.08	1.0	4.0	490	383	1850	0.125
R06X1.571	06		1.5	3.0	735	539	2900	0.169
R08X171	08	±0.08	1.0	6.0	368	297	1300	0.175
R08X1.571	08		1.5	5.0	551	424	2050	0.244
R10X171	10	±0.08	1.0	8.0	294	242	950	0.225
R10X1.571	10		1.5	7.0	441	349	1750	0.319
R10X271	10		2.0	6.0	588	447	2400	0.401
R12X171	12	±0.08	1.0	10.0	245	205	850	0.275
R12X1.571	12		1.5	9.0	368	297	1400	0.394
R12X271	12		2.0	8.0	490	383	1900	0.501
R14X1.571	14	±0.08	1.5	11.0	315	258	1200	0.469
R14X271	14		2.0	10.0	420	334	1550	0.601
R14X2.571	14		2.5	9.0	525	406	2100	0.720
R15X171	15	±0.08	1.0	13.0	196	166	675	0.351
R15X1.571	15		1.5	12.0	294	242	1100	0.507
R15X271	15		2.0	11.0	392	314	1400	0.651
R16X1.571	16	±0.08	1.5	13.0	276	228	950	0.545
R16X271	16		2.0	12.0	368	297	1300	0.701
R16X2.571	16		2.5	11.0	459	362	1850	0.845
R16X371	16		3.0	10.0	551	424	2400	0.977
R18X1.571	18	±0.08	1.5	15.0	245	205	800	0.620
R18X271	18		2.0	14.0	327	267	1150	0.801
R20X271	20	±0.08	2.0	16.0	294	242	1050	0.901
R20X2.571	20		2.5	15.0	368	297	1400	1.095
R20X371	20		3.0	14.0	441	349	1800	1.277
R22X1.571	22	±0.08	1.5	19.0	200	170	650	0.770
R22X271	22		2.0	18.0	267	222	900	1.002
R25X271	25	±0.08	2.0	21.0	235	197	763	1.152
R25X2.571	25		2.5	20.0	294	242	1050	1.408
R25X371	25		3.0	19.0	353	286	1275	1.653
R28X1.571	28	±0.08	1.5	25.0	158	135	550	0.995
R28X271	28		2.0	24.0	210	177	700	1.302
R28X2.571	28		2.5	23.0	263	218	(840)	1.596
R30X2.571	30	±0.08	2.5	25.0	245	205	850	1.722
R30X371	30		3.0	24.0	294	242	1150	2.028
R30X471	30		4.0	22.0	392	314	1500	2.605
R35X271	35	±0.15	2.0	31.0	168	143	550	1.653
R35X2.571	35		2.5	30.0	210	177	(659)	2.035
R35X371	35		3.0	29.0	252	210	(803)	2.404
R38X2.571	38	±0.15	2.5	33.0	193	164	628	2.222
R38X471	38		4.0	30.0	309	254	1150	3.405
R42X271	42	±0.20	2.0	38.0	140	121	475	2.003
R42X371	42		3.0	36.0	210	177	750	2.930

Other sizes on request!

EO-Tubes for fitting systems (Industrial- and Mobile-Applications)

Seamless EO stainless steel tubes | Material 316L (1.4404)

Acc. to ASTM A269/A213

1. DIN 2413 I static pressure (W.P.) capability for straight pipe including manufacturing tolerance.
2. Burst pressure (B.P.) acc. to Faupel-von-Mises

Material 316L (1.4404)		d _a Outer-Ø (mm)	Outer-Ø Tolerance (mm)	s Wall- thickness (mm)	d _i Inner-Ø (mm)	1 Design pressure		2 Burst pressure bar	Weight kg/m
pickled	bright annealed					DIN 2413 I static PN bar	DIN 2413 III dynamic PN bar		
Order code									
	R04X1-316BA	04	±0.08	1.0	2.0	735	539	2961	0.075
	R06X1-316BA	06	±0.08	1.0	4.0	490	383	1732	0.125
	R06X1.5-316BA	06		1.5	3.0	735	539	2961	0.169
	R08X1-316BA	08	±0.08	1.0	6.0	368	297	1229	0.175
	R10X1-316BA	10	±0.08	1.0	8.0	294	242	953	0.225
	R10X1.5-316BA	10		1.5	7.0	441	349	1524	0.319
	R10X2-316BA	10		2.0	6.0	588	447	2182	0.401
	R12X1-316BA	12	±0.08	1.0	10.0	245	205	779	0.275
	R12X1.5-316BA	12		1.5	9.0	368	297	1229	0.394
	R12X2-316BA	12		2.0	8.0	490	383	1732	0.501
	R15X1.5-316BA	15	±0.08	1.5	12.0	294	242	953	0.507
	R16X2-316	16	±0.08	2.0	12.0	368	297	1229	0.701
	R16X2.5-316	16		2.5	11.0	459	362	1601	0.845
	R18X1.5-316	18	±0.08	1.5	15.0	245	205	779	0.620
	R18X2-316	18		2.0	14.0	327	267	1074	0.801
	R20X2-316	20	±0.08	2.0	16.0	294	242	953	0.901
	R20X2.5-316	20		2.5	15.0	368	297	1229	1.096
	R22X2-316	22	±0.08	2.0	18.0	267	222	857	1.002
	R25X2-316	25	±0.08	2.0	21.0	235	197	745	1.152
	R25X2.5-316	25		2.5	20.0	294	242	953	1.409
	R25X3-316	25		3.0	19.0	353	286	1172	1.653
	R28X2-316	28	±0.08	2.0	24.0	210	177	659	1.302
	R30X2.5-316	30	±0.08	2.5	25.0	245	205	779	1.722
	R30X3-316	30		3.0	24.0	294	242	953	2.028
	R35X3-316	35	±0.15	3.0	29.0	252	210	803	2.404
	R38X3-316	38	±0.15	3.0	32.0	232	195	734	2.629
	R38X4-316	38		4.0	30.0	309	254	1010	3.405
	R38X5-316	38		5.0	28.0	387	311	1305	4.132
	R38X6-316	38		6.0	26.0	464	365	1621	4.808
	R42X3-316	42	±0.20	3.0	36.0	210	177	659	2.930

Other sizes on request!

Seamless EO stainless steel tubes | Material 316L (1.4404)

Acc. to DIN EN 10216-5, DIN EN 10305-1

1. DIN 2413 I: Tubes with a diameter of OD/ID>2 are calculated for static stress in accordance with DIN 2413 III but with K=yield strength.
2. Burst pressure (B.P.) calculation acc. to Faupel-von-Mises

Material 316 L (1.4404)	d _a Outer-Ø (mm)		s Wallthickness		d Inner-Ø (mm)	1 Design pressure			Weight kg/m
						DIN 2413 I static PN bar	DIN 2413 III dynamic PN bar	2 Burst pressure bar	
	Surface bright annealed	Inch	mm	Inch		mm	Order code		
R1/8X0.028TP316/L	1/8	3.18	0.028	0.71	1.76	659	492	2538	0.044
R3/16X0.035TP316/L	3/16	4.76	0.035	0.89	2.98	549	422	1996	0.086
R1/4X0.035TP316/L	1/4	6.35	0.035	0.89	4.57	412	328	1403	0.122
R1/4X0.049TP316/L			0.049	1.24	3.87	576	440	2126	0.159
R1/4X0.065TP316/L			0.065	1.65	3.05	619	556	3135	0.194
R3/8X0.035TP316/L	3/8	9.53	0.035	0.89	7.75	274	227	883	0.193
R3/8X0.049TP316/L			0.049	1.24	7.05	384	309	1294	0.257
R3/8X0.065TP316/L			0.065	1.65	6.23	510	396	1818	0.326
R1/2X0.035TP316/L	1/2	12.70	0.035	0.89	10.92	206	174	644	0.263
R1/2X0.049TP316/L			0.049	1.24	10.22	288	238	932	0.356
R1/2X0.065TP316/L			0.065	1.65	9.40	382	307	1286	0.457
R1/2X0.083TP316/L			0.083	2.11	8.48	488	381	1724	0.560
R5/8X0.049TP316/L	5/8	15.88	0.049	1.24	13.40	230	193	729	0.455
R5/8X0.065TP316/L			0.065	1.65	12.58	306	251	996	0.588
R3/4X0.049TP316/L	3/4	19.05	0.049	1.24	16.57	192	163	598	0.553
R3/4X0.065TP316/L			0.065	1.65	15.75	255	212	813	0.719
R3/4X0.083TP316/L			0.083	2.11	14.83	325	266	1069	0.895
R3/4X0.095TP316/L			0.095	2.41	14.23	372	300	1248	1.004
R3/4X0.109TP316/L			0.109	2.77	13.51	427	339	1467	1.129
R1X0.065TP316/L	1	25.40	0.065	1.65	22.10	191	162	595	0.981
R1X0.083TP316/L			0.083	2.11	21.18	244	204	775	1.231
R1X0.095TP316/L			0.095	2.41	20.58	279	231	900	1.387
R1X0.126TP316/L			0.126	3.20	19.00	370	299	1240	1.779

Other sizes on request!

EO-Tubes for flange systems - Marine- and Offshore-Applications (DNV Rules)

Seamless EO steel tubes | Material E235+N / St.37.4 (1.0308)

Acc. to DIN EN 10305-4

1. DNV Bended pipe including manufacturing and corrosion tolerances.
2. DNV Straight pipe including manufacturing and corrosion tolerances.
3. Burst pressure (B.P.) calculation = Based on Tensile value, wall thickness tolerance not included.

Material E235+N / St.37.4 (1.0308)		d _a Outer-Ø (mm)	Outer-Ø Tolerance (mm)	s Wall- thickness (mm)	d _i Inner-Ø (mm)	Design pressure			Weight kg/m
Surface						1 DNV PN bar	2 DNV PN bar	3 Burst pressure bar	
Phosphated and oiled	Cr(VI)-free								
Order code									
R12X1.5	R12X1.5CF	12	±0.08	1.5	9.0	218	250	1114	0.388
R16X2	R16X2CF	16	±0.08	2.0	12.0	235	270	1114	0.691
R18X2	R18X2CF	18	±0.08	2.0	14.0	207	237	975	0.789
R20X2	R20X2CF	20	±0.08	2.0	16.0	185	212	867	0.888
R20X2.5	R20X2.5CF	20	±0.08	2.5	15.0	246	282	1114	1.079
R25X2.5	R25X2.5CF	25	±0.08	2.5	20.0	193	221	867	1.387
R25X3	R25X3CF	25	±0.08	3.0	19.0	242	277	1064	1.628
R30X3	R30X3CF	30	±0.08	3.0	24.0	198	227	867	1.998
R30X4	R30X4CF	30	±0.08	4.0	22.0	281	323	1200	2.565
R38X3	R38X2.5CF	38	±0.15	2.5	33.0	124	141	549	2.189
R38X3	R38X3CF	38		3.0	32.0	154	176	669	2.589
R38X4	R38X4CF	38		4.0	30.0	217	248	918	3.354
R38X5	R38X5CF	38		5.0	28.0	282	324	1182	4.069
R42X2	R42X2CF	42	±0.20	2.0	38.0	85	97	390	1.973
R42X3	R42X3CF	42		3.0	36.0	139	158	600	2.885
R42X4	R42X4CF	42		4.0	34.0	194	223	821	3.748
R50X3	R50X3CF	50	±0.20	3.0	44.0	115	132	498	3.477
R50X6	R50X6CF	50		6.0	38.0	258	296	1064	6.511
R60X3	R60X3CF	60	±0.25	3.0	54.0	95	109	411	4.217
R65X8		65	±0.30	8.0	49.0	270	310	1095	11.245
R75X3	R75X3CF	75	±0.35	3.0	69.0	76	86	325	5.327
R90X3.5	R90X3.5CF	90	±0.40	3.5	83.0	75	85	316	7.466
R100X4		100	±0.45	4.0	92.0	78	89	325	9.470
R115X4		115	±0.50	4.0	107.0	68	77	281	10.949
R140X4.5		140	±0.70	4.5	131.0	63	72	259	15.037
R165X5		165	±0.90	5.0	155.0	60	68	244	19.729
R220X6		220	±1.10	6.0	208.0	55	62	219	31.665
R273X6		273	±1.40	6.0	261.0	44	50	175	39.507

Surface finish:

- Tubes with I.D. 1.5-5 mm: outside and inside oiled.
- Tubes from 6 mm I.D.: outside and inside phosphated and oiled.

• Cr(VI)-free:

These dimensions are externally thick coat passivated (thickness of coat 8-12µm), inside oiled.

Other sizes on request!

Seamless EO steel tubes | Material E235+N / St.37.4 (1.0308)

Acc. to DIN EN 10305-4

1. DIN 2413 I static pressure (W.P.) capability for straight pipe including manufacturing tolerance.
2. DIN 2413 III dynamic pressure (W.P.) capability for straight pipe including manufacturing tolerance.
3. Burst pressure (B.P.) calculation acc. to Faupel-von-Mises

Material E235+N / St.37.4 (1.0308)		d _a Outer-Ø (mm)	Outer-Ø Tolerance (mm)	s Wall- thickness (mm)	d _i Inner-Ø (mm)	Design pressure			Weight kg/m
Surface						1 DIN 2413 I static PN bar	2 DIN 2413 III dynamic PN bar	3 Burst pressure bar	
Phosphated and oiled	Cr(VI)-free								
Order code									
R12X1.5	R12X1.5CF	12	±0.08	1.5	9.0	353	303	1022	0.388
R16X2	R16X2CF	16	±0.08	2.0	12.0	353	303	1022	0.691
R18X2	R18X2CF	18	±0.08	2.0	14.0	313	273	893	0.789
R20X2	R20X2CF	20	±0.08	2.0	16.0	282	248	793	0.888
R20X2.5	R20X2.5CF	20		2.5	15.0	353	303	1022	1.079
R25X2.5	R25X2.5CF	25	±0.08	2.5	20.0	282	248	793	1.387
R25X3	R25X3CF	25		3.0	19.0	338	292	975	1.628
R30X3	R30X3CF	30	±0.08	3.0	24.0	282	248	793	1.998
R30X4	R30X4CF	30		4.0	22.0	376	321	1102	2.565
R38X3 R38X4 R38X4 R38X5	R38X2.5CF	38	±0.15	2.5	33.0	186	168	501	2.189
	R38X3CF	38		3.0	32.0	223	199	610	2.589
	R38X4CF	38		4.0	30.0	297	260	840	3.354
	R38X5CF	38		5.0	28.0	371	318	1085	4.069
R42X2	R42X2CF	42	±0.20	2.0	38.0	134	123	355	1.973
R42X3	R42X3CF	42		3.0	36.0	201	181	547	2.885
R42X4	R42X4CF	42		4.0	34.0	269	237	750	3.748
R50X3	R50X3CF	50	±0.20	3.0	44.0	169	154	454	3.477
R50X6		50		6.0	38.0	338	292	975	6.511
R60X3	R60X3CF	60	±0.25	3.0	54.0	141	129	374	4.217
R65X8		65	±0.30	8.0	49.0	347	299	1004	11.245
R75X3	R75X3CF	75	±0.35	3.0	69.0	113	104	296	5.327
R90X3.5	R90X3.5CF	90	±0.40	3.5	83.0	110	101	288	7.466
R100X4		100	±0.45	4.0	92.0	113	104	296	9.470
R115X4		115	±0.50	4.0	107.0	98	91	256	10.949
R140X4.5		140	±0.70	4.5	131.0	91	84	236	15.037
R165X5		165	±0.90	5.0	155.0	85	80	222	19.729
R220X6		220	±1.10	6.0	208.0	77	72	199	31.665
R273X6		273	±1.40	6.0	261.0	62	58	160	39.507

Surface finish:

- Tubes with I.D. 1.5-5 mm: outside and inside oiled.
- Tubes from 6 mm I.D.: outside and inside phosphated and oiled.

• Cr(VI)-free:

These dimensions are externally thick coat passivated (thickness of coat 8-12µm), inside oiled.

Other sizes on request!

EO-Tubes for flange systems- Marine- and Offshore-Applications (DNV Rules)

Seamless EO steel tubes | Material E355+N / St.52.4 (1.0580)

Acc. to DIN EN 10305-4

1. DNV Bended pipe including manufacturing and corrosion tolerances.
2. DNV Straight pipe including manufacturing and corrosion tolerances.
3. Burst pressure (B.P.) calculation = Based on Tensile value, wall thickness tolerance not included.

Material E355+N / St. 52.4 (1.0580)		d _a Outer-Ø (mm)	Outer-Ø Tolerance (mm)	s Wall- thickness (mm)	d _i Inner-Ø (mm)	Design pressure			Weight kg/m
Surface						1 DNV PN bar	2 DNV PN bar	3 Burst pressure bar	
Phosphated and oiled	Cr(VI)-free								
Order code									
	R12X1.5ST52CF	12	±0.08	1.5	9.0	330	378	1523	0.388
R16X2ST52	R16X2ST52CF	16	±0.08	2.0	12.0	355	408	1523	0.691
	R18X2ST52CF	18	±0.08	2.0	14.0	313	358	1333	0.789
R20X2ST52	R20X2ST52CF	20	±0.08	2.0	16.0	279	319	1184	0.888
R20X2.5ST52	R20X2.5ST52CF	20	±0.08	2.5	15.0	371	426	1523	1.079
R25X3ST52	R25X2.5ST52CF	25	±0.08	2.5	20.0	291	333	1184	1.387
	R25X3ST52CF	25	±0.08	3.0	19.0	365	418	1454	1.628
	R25X4ST52CF	25	±0.08	4.0	17.0	519	599	2030	2.072
R30X3ST52	R30X3ST52CF	30	±0.08	3.0	24.0	299	343	1184	1.998
	R30X4ST52CF	30	±0.08	4.0	22.0	424	487	1640	2.565
	R30X5ST52CF	30	±0.08	5.0	20.0	555	641	2132	3.083
R38X4ST52	R38X3ST52CF	38	±0.15	3.0	32.0	233	266	914	2.589
	R38X4ST52CF	38	±0.15	4.0	30.0	327	375	1254	3.354
	R38X5ST52CF	38	±0.15	5.0	28.0	426	490	1615	4.069
	R38X6ST52CF	38	±0.15	6.0	26.0	529	611	1999	4.735
	R39X7.5ST52CF	39	±0.15	7.5	24.0	673	781	2538	5.826
	R42X3ST52CF	42	±0.20	3.0	36.0	209	239	820	2.885
	R42X4ST52CF	42	±0.20	4.0	34.0	294	336	1122	3.748
	R42X5ST52CF	42	±0.20	5.0	32.0	381	438	1441	4.562
	R46X8ST52CF	46	±0.20	8.0	30.0	601	695	2244	7.497
R50X5ST52	R50X3ST52CF	50	±0.20	3.0	44.0	174	199	680	3.477
	R50X5ST52CF	50	±0.20	5.0	40.0	315	361	1184	5.549
	R50X6ST52CF	50	±0.20	6.0	38.0	390	448	1454	6.511
	R50X8ST52CF	50	±0.20	8.0	34.0	546	631	2030	8.286
R56X8.5ST52	R56X8.5ST52CF	56	±0.25	8.5	39.0	516	595	1908	9.957
R60X6ST52	R60X3ST52CF	60	±0.25	3.0	54.0	144	164	561	4.217
	R60X5ST52CF	60	±0.25	5.0	50.0	259	297	969	6.782
	R60X6ST52CF	60	±0.25	6.0	48.0	319	366	1184	7.990
	R60X8ST52CF	60	±0.25	8.0	44.0	445	512	1640	10.259
	R65X8ST52CF	65	±0.30	8.0	49.0	407	468	1496	11.245
R66X8.5ST52	R66X8.5ST52CF	66	±0.30	8.5	49.0	429	494	1576	12.053
R73X7ST52	R73X7ST52CF	73	±0.35	7.0	59.0	308	353	1131	11.393
R75X5ST52	R75X5ST52CF	75	±0.35	5.0	65.0	205	234	761	8.631
R75X12.5ST52	R75X12.5ST52CF	75	±0.35	12.5	50.0	583	674	2132	19.266
R80X3ST52		80	±0.35	3.0	74.0	107	122	415	5.697
R80X8ST52		80	±0.35	8.0	64.0	325	372	1184	14.205
R80X10ST52		80	±0.35	10.0	60.0	418	481	1523	17.263
R88X14ST52		88	±0.40	14.0	60.0	554	640	2017	25.549
R90X3.5ST52		90	±0.40	3.5	83.0	113	129	431	7.466
R90X5ST52		90	±0.40	5.0	80.0	169	193	627	10.481
R90X9ST52		90	±0.40	9.0	72.0	326	374	1184	17.978
R97X12ST52		97	±0.45	12.0	73.0	416	478	1505	25.154
R115X15ST52		115	±0.50	15.0	85.0	444	511	1599	36.992
R120X20ST52		120	±0.50	20.0	80.0	590	682	2132	49.322
R130X15ST52		130	±0.70	15.0	100.0	388	445	1390	42.540
R150X15ST52		150	±0.80	15.0	120.0	332	380	1184	49.939
R190X20ST52		190	±1.00	20.0	150.0	353	405	1254	83.847
R250X25ST52		250	±1.30	25.0	200.0	335	384	1184	138.718

Other sizes on request!

Seamless EO steel tubes | Material E355+N / St.52.4 (1.0580)

Acc. to DIN EN 10305-4

1. DIN 2413 I static pressure (W.P.) capability for straight pipe including manufacturing tolerance.
2. DIN 2413 III dynamic pressure (W.P.) capability for straight pipe including manufacturing tolerance.
3. Burst pressure (B.P.) calculation acc. to Faupel-von-Mises

Material E355+N / St. 52.4 (1.0580)		d _a Outer-Ø (mm)	OuterØ Tolerance (mm)	s Wal- thickness (mm)	d _i Inner-Ø (mm)	Design pressure			Weight kg/m
Surface						1 DIN 2413 I static PN bar	2 DIN 2413 III dynamic PN bar	3 Burst pressure bar	
Phosphated and oiled	Cr(VI)-free								
Order code									
	R12X1.5ST52CF	12	±0.08	1.5	9.0	533	357	1504	0.388
R16X2ST52	R16X2ST52CF	16	±0.08	2.0	12.0	533	357	1504	0.691
	R18X2ST52CF	18	±0.08	2.0	14.0	473	321	1314	0.789
R20X2ST52	R20X2ST52CF	20	±0.08	2.0	16.0	426	292	1167	0.888
R20X2.5ST52	R20X2.5ST52CF	20	±0.08	2.5	15.0	533	357	1504	1.079
R25X3ST52	R25X2.5ST52CF	25	±0.08	2.5	20.0	426	292	1167	1.387
	R25X3ST52CF	25	±0.08	3.0	19.0	511	344	1435	1.628
	R25X4ST52CF	25	±0.08	4.0	17.0	682	445	2016	2.072
R30X3ST52	R30X3ST52CF	30	±0.08	3.0	24.0	426	292	1167	1.998
	R30X4ST52CF	30	±0.08	4.0	22.0	568	379	1622	2.565
	R30X5ST52CF	30	±0.08	5.0	20.0	710	461	2120	3.083
R38X4ST52	R38X3ST52CF	38	±0.15	3.0	32.0	336	234	899	2.589
	R38X4ST52CF	38	±0.15	4.0	30.0	448	306	1236	3.354
	R38X5ST52CF	38	±0.15	5.0	28.0	561	374	1597	4.069
	R38X6ST52CF	38	±0.15	6.0	26.0	673	440	1984	4.735
	R39X7.5ST52CF	39	±0.15	7.5	24.0	819	521	2539	5.826
	R42X3ST52CF	42	±0.20	3.0	36.0	304	213	806	2.885
	R42X4ST52CF	42	±0.20	4.0	34.0	406	279	1105	3.748
	R42X5ST52CF	42	±0.20	5.0	32.0	507	342	1422	4.562
	R46X8ST52CF	46	±0.20	8.0	30.0	741	478	2235	7.497
R50X5ST52	R50X3ST52CF	50	±0.20	3.0	44.0	256	181	668	3.477
	R50X5ST52CF	50	±0.20	5.0	40.0	426	292	1167	5.549
	R50X6ST52CF	50	±0.20	6.0	38.0	511	344	1435	6.511
	R50X8ST52CF	50	±0.20	8.0	34.0	682	445	2016	8.286
R56X8.5ST52	R56X8.5ST52CF	56	±0.25	8.5	39.0	647	425	1892	9.957
R60X6ST52	R60X3ST52CF	60	±0.25	3.0	54.0	213	152	551	4.217
	R60X5ST52CF	60	±0.25	5.0	50.0	355	247	953	6.782
	R60X6ST52CF	60	±0.25	6.0	48.0	426	292	1167	7.990
	R60X8ST52CF	60	±0.25	8.0	44.0	568	379	1622	10.259
	R65X8ST52CF	65	±0.30	8.0	49.0	524	352	1477	11.245
R66X8.5ST52	R66X8.5ST52CF	66	±0.30	8.5	49.0	549	367	1557	12.053
R73X7ST52	R73X7ST52CF	73	±0.35	7.0	59.0	408	281	1113	11.393
R75X5ST52	R75X5ST52CF	75	±0.35	5.0	65.0	284	200	748	8.631
R75X12.5ST52	R75X12.5ST52CF	75	±0.35	12.5	50.0	710	461	2120	19.266
R80X3ST52		80	±0.35	3.0	74.0	160	115	408	5.697
R80X8ST52		80	±0.35	8.0	64.0	426	292	1167	14.205
R80X10ST52		80	±0.35	10.0	60.0	533	357	1504	17.263
R88X14ST52		88	±0.40	14.0	60.0	678	443	2002	25.549
R90X3.5ST52		90	±0.40	3.5	83.0	166	119	423	7.466
R90X5ST52		90	±0.40	5.0	80.0	237	168	616	10.481
R90X9ST52		90	±0.40	9.0	72.0	426	292	1167	17.978
R97X12ST52		97	±0.45	12.0	73.0	527	354	1486	25.154
R115X15ST52		115	±0.50	15.0	85.0	556	371	1580	36.992
R120X20ST52		120	±0.50	20.0	80.0	710	461	2120	49.322
R130X15ST52		130	±0.70	15.0	100.0	492	332	1372	42.540
R150X15ST52		150	±0.80	15.0	120.0	426	292	1167	49.939
R190X20ST52		190	±1.00	20.0	150.0	448	306	1236	83.847
R250X25ST52		250	±1.30	25.0	200.0	426	292	1167	138.718

Other sizes on request!

EO-Tubes for flange systems - Marine- and Offshore-Applications (DNV Rules)

Seamless cold drawn EO stainless steel tube | Material 316Ti (1.4571)

Acc. to ASTM A269/A213, DIN EN 10305-4

1. DNV Bended pipe including manufacturing and corrosion tolerances.
2. DNV Straight pipe including manufacturing and corrosion resistance.
3. Burst pressure (B.P.) calculation = Based on Tensile value, wall thickness tolerance not included.

Material 316Ti (1.4571)	d _a Outer-Ø (mm)	OuterAußen-Ø Tolerance (mm)	s Wall- thickness (mm)	d _i Inner-Ø (mm)	Design pressure		3 Burst pressure bar	Weight kg/m
					1 DNV PN bar	2 DNV PN bar		
Surface bright annealed								
Order code								
R12X1.571	12	±0.08	1.5	9.0	380	437	1514	0.394
R16X271	16	±0.08	2.0	12.0	380	437	1514	0.701
R18X271	18	±0.08	2.0	14.0	334	383	1325	0.801
R20X271	20	±0.08	2.0	16.0	298	341	1178	0.901
R20X2.571	20	±0.08	2.5	15.0	380	437	1514	1.096
R25X2.571	25	±0.08	2.5	20.0	298	341	1178	1.409
R25X371	25	±0.08	3.0	19.0	363	418	1445	1.653
R30X371	30	±0.08	3.0	24.0	298	341	1178	2.028
R30X471	30	±0.08	4.0	22.0	409	470	1631	2.604
R38X2.571	38	±0.15	2.5	33.0	190	217	746	2.222
R38X471	38	±0.15	4.0	30.0	315	361	1247	3.405
R42X371	42	±0.20	3.0	36.0	207	237	815	2.930

Other sizes on request!

Seamless cold drawn EO stainless steel tube | Material 316Ti (1.4571)

Acc. to ASTM A269/A213, DIN EN 10305-4

1. DIN 2413 I static pressure (W.P.) capability for straight pipe including manufacturing tolerance.
2. DIN 2413 III dynamic pressure (W.P.) capability for straight pipe including manufacturing tolerance.
3. Burst pressure (B.P.) calculation acc. to Faupel-von-Mises.

Material 316Ti (1.4571)	d _a Outer-Ø (mm)	Outer-Ø Tolerance (mm)	s Wall- thickness (mm)	d _i Inner-Ø (mm)	Design pressure		3 Burst pressure bar	Weight kg/m
					1	2		
					DIN 2413 I static PN bar	DIN 2413 III dynamic PN bar		
R12X1.571	12	±0.08	1.5	9.0	368	297	1229	0.394
R16X271	16	±0.08	2.0	12.0	368	297	1229	0.701
R18X271	18	±0.08	2.0	14.0	327	267	1074	0.801
R20X271	20	±0.08	2.0	16.0	294	242	953	0.901
R20X2.571	20	±0.08	2.5	15.0	368	297	1229	1.096
R25X2.571	25	±0.08	2.5	20.0	294	242	953	1.409
R25X371	25	±0.08	3.0	19.0	353	286	1172	1.653
R30X371	30	±0.08	3.0	24.0	294	242	958	2.028
R30X471	30	±0.08	4.0	22.0	392	314	1325	2.604
R38X2.571	38	±0.15	2.5	33.0	193	164	603	2.222
R38X471	38	±0.15	4.0	30.0	309	254	1010	3.405
R42X371	42	±0.20	3.0	36.0	210	177	659	2.930

Other sizes on request!

EO-Tubes for Flange systems - Marine- and Offshore-Applications (DNV Rules)

Seamless cold drawn EO stainless steel tube | Material 316L (1.4404)

Acc. to ASTM A269/A213, DIN EN 10305-4

1. DNV Bended pipe including manufacturing and corrosion tolerances.
2. DNV Straight pipe including manufacturing and corrosion tolerances.
3. Burst pressure (B.P.) calculation = Based on Tensile value, wall thickness tolerance not included.

Material 316L (1.4404)		d _a Outer-Ø (mm)	Outer-Ø Tolerance (mm)	s Wall- thickness (mm)	d _i Inner-Ø (mm)	Design pressure		3 Burst pressure bar	Weight kg/m
pickled	bright annealed					1 DNV PN bar	2 DNV PN bar		
Order code									
	R12X1.5-316BA	12	±0.08	1.5	9.0	380	437	1514	0.394
R16X2-316		16	±0.08	2.0	12.0	380	437	1514	0.701
R18X2-316		18	±0.08	2.0	14.0	334	383	1325	0.801
R20X2-316		20	±0.08	2.0	16.0	298	341	1178	0.901
R20X2.5-316		20	±0.08	2.5	15.0	380	437	1514	1.096
R25X2.5-316		25	±0.08	2.5	20.0	298	341	1178	1.409
R25X3-316		25	±0.08	3.0	19.0	363	418	1445	1.653
R30X3-316		30	±0.08	3.0	24.0	298	341	1178	2.028
R30X4-316		30	±0.08	4.0	22.0	409	470	1631	2.604
R38X2.5-316		38	±0.15	2.5	33.0	190	217	746	2.222
R38X3-316		38	±0.15	3.0	32.0	231	264	909	2.629
R38X4-316		38	±0.15	4.0	30.0	315	361	1247	3.405
R38X5-316		38	±0.15	5.0	28.0	403	463	1606	4.132
R42X3-316		42	±0.20	3.0	36.0	207	237	815	2.930
R50X3-316		50	±0.20	3.0	44.0	173	197	677	3.531
R50X5-316		50	±0.20	5.0	40.0	298	341	1178	5.634
R50X6-316		50	±0.20	6.0	38.0	363	418	1445	6.611
R60X3-316		60	±0.25	3.0	54.0	143	163	558	4.282
R60X5-316		60	±0.25	5.0	50.0	244	280	964	6.886
R60X6-316		60	±0.25	6.0	48.0	298	341	1178	8.113
R66X8.5-316		66	±0.30	8.5	49.0	393	452	1567	12.238
R73X7-316		73	±0.35	7.0	59.0	284	326	1124	11.568
R75X3-316		75	±0.35	3.0	69.0	113	129	442	5.409
R75X5-316		75	±0.35	5.0	65.0	193	220	757	8.764
R80X10-316		80	±0.35	10.0	60.0	380	437	1514	17.528

Other sizes on request!

Seamless cold drawn EO stainless steel tube | Material 316L (1.4404)

Acc. to ASTM A269/A213, DIN EN 10305-4

1. DIN 2413 I static pressure (W.P.) capability for straight pipe including manufacturing tolerance.
2. DIN 2413 III dynamic pressure (W.P.) capability for straight pipe including manufacturing tolerance.
3. Burst pressure (B.P.) calculation acc. to Faupel-von-Mises

Material 316L (1.4404)		d _a Outer-Ø (mm)	Outer-Ø Tolerance (mm)	s Wall- thickness (mm)	d _i Inner-Ø (mm)	Design pressure		3 Burst pressure bar	Weight kg/m
Surface						1 DIN 2413 I static PN bar	2 DIN 2413 III dynamic PN bar		
pickled	bright annealed								
Order code									
	R12X1.5-316BA	12	±0.08	1.5	9.0	368	297	1229	0.394
R16X2-316		16	±0.08	2.0	12.0	368	297	1229	0.701
R18X2-316		18	±0.08	2.0	14.0	327	267	1074	0.801
R20X2-316		20	±0.08	2.0	16.0	294	242	953	0.901
R20X2.5-316		20	±0.08	2.5	15.0	368	297	1229	1.096
R25X2.5-316		25	±0.08	2.5	20.0	294	242	953	1.409
R25X3-316		25	±0.08	3.0	19.0	353	286	1172	1.653
R30X3-316		30	±0.08	3.0	24.0	294	242	953	2.028
R30X4-316		30	±0.08	4.0	22.0	392	314	1325	2.604
R38X2.5-316		38	±0.15	2.5	33.0	193	164	603	2.222
R38X3-316		38	±0.15	3.0	32.0	232	195	734	2.629
R38X4-316		38	±0.15	4.0	30.0	309	254	1010	3.405
R38X5-316		38	±0.15	5.0	28.0	387	311	1305	4.132
R42X3-316		42	±0.20	3.0	36.0	210	177	659	2.930
R50X3-316		50	±0.20	3.0	44.0	176	150	546	3.531
R50X5-316		50	±0.20	5.0	40.0	294	242	953	5.634
R50X6-316		50	±0.20	6.0	38.0	353	286	1172	6.611
R60X3-316		60	±0.25	3.0	54.0	147	126	450	4.282
R60X5-316		60	±0.25	5.0	50.0	245	205	779	6.886
R60X6-316		60	±0.25	6.0	48.0	294	242	953	8.113
R66X8.5-316		66	±0.30	8.5	49.0	379	305	1272	12.238
R73X7-316		73	±0.35	7.0	59.0	282	233	910	11.568
R75X3-316		75	±0.35	3.0	69.0	118	102	356	5.409
R75X5-316		75	±0.35	5.0	65.0	196	166	611	8.764
R80X10-316		80	±0.35	10.0	60.0	368	297	1229	17.528

Other sizes on request!

Tubes for flange systems – Scheduled sizes

Seamless stainless steel tubes | Material 316L (1.4404)

Acc. to ASTM A312/A999

Pressure table acc. to DNV Rules for Classification of Ships Newbuilding and Mobile Offshore Units Drilling Plants.

1. DNV Bended pipe including manufacturing and corrosion tolerances.
2. DNV Straight pipe including manufacturing and corrosion tolerances.
3. Burst pressure (B.P.) calculation = Based on Tensile value, wall thickness tolerance not included.

Material 316L (1.4404) Surface pickled Order code	d _a Outer-Ø		s Wallthickness		d _i Inner-Ø (mm)	Design pressure		3 Burst pressure bar	Weight kg/m
	SCH	mm	SCH	mm		1 DNV PN bar	2 DNV PN bar		
R21.34X2.11-316 R21.34X2.77-316 R21.34X3.73-316 R21.34X4.78-316	1/2"	21.34	SCH 10	2.11	17.12	241	277	1130	1.014
SCH 40			2.77	15.80	325	374	1536	1.285	
SCH 80			3.73	13.88	456	527	2182	1.641	
SCH 160			4.78	11.78	611	712	2973	1.977	
R26.67X2.11-316 R26.67X2.81-316 R26.67X3.91-316 R26.67X5.56-316	3/4"	26.67	SCH 10	2.11	24.56	190	217	885	1.299
SCH 40			2.81	21.05	259	297	1213	1.713	
SCH 80			3.91	18.85	373	430	1769	2.231	
SCH 160			5.56	15.55	560	651	2713	2.943	
R33.40X2.77-316-A999 R33.40X3.38-316-A999 R33.40X4.55-316-A999 R33.40X6.35-316-A999	1"	33.40	SCH 10	2.77	27.86	200	228	931	2.125
SCH 40			3.38	30.02	247	284	1160	2.541	
SCH 80			4.55	24.30	343	395	1624	3.287	
SCH 160			6.35	20.70	502	583	2418	4.301	
R42.16X2.77-316-A999 R42.16X3.56-316-A999 R42.16X4.85-316-A999 R42.16X6.35-316-A999	1 1/4"	42.16	SCH 10	2.77	36.62	156	178	724	2.735
SCH 40			3.56	35.04	204	233	950	3.444	
SCH 80			4.85	32.46	285	327	1339	4.536	
SCH 160			6.35	29.46	384	443	1826	5.700	
R48.26X2.77-316-A999 R48.26X3.68-316-A999 R48.26X5.08-316-A999 R48.26X7.14-316-A999	1 1/2"	48.26	SCH 10	2.77	42.72	135	154	627	3.158
SCH 40			3.68	40.90	183	209	850	4.112	
SCH 80			5.08	38.10	258	296	1212	5.498	
SCH 160			7.14	33.98	377	434	1788	7.359	
R60.33X2.77-316-A999 R60.33X3.91-316-A999 R60.33X5.54-316-A999 R60.33X8.74-316-A999	2"	60.33	SCH 10	2.77	54.76	107	122	496	3.990
SCH 40			3.91	52.48	154	176	714	5.521	
SCH 80			5.54	49.22	223	255	1041	7.596	
SCH 160			8.74	42.82	368	424	1745	11.284	
R73.03X3.05-316-A999 R73.03X5.16-316-A999 R73.03X7.01-316-A999 R73.03X9.53-316-A999	2 1/2"	73.03	SCH 10	3.05	66.90	97	111	449	5.342
SCH 40			5.16	62.68	168	192	783	8.765	
SCH 80			7.01	58.98	234	268	1094	11.583	
SCH 160			9.53	53.94	327	376	1546	15.146	
R88.90X3.05-316 R88.90X5.49-316-A999 R88.90X7.62-316-A999 R88.90X11.13-316-A999	3"	88.90	SCH 10	3.05	82.80	79	90	366	6.557
SCH 40			5.49	77.92	146	167	678	11.466	
SCH 80			7.62	73.56	207	237	966	15.509	
SCH 160			11.13	66.64	312	359	1474	21.674	
R114.30X3.05-316 R114.30X6.02-316-A999 R114.30X8.56-316-A999 R114.30X13.49-316-A999	4"	114.30	SCH 10	3.05	108.20	61	70	282	8.496
SCH 40			6.02	102.16	124	141	573	16.322	
SCH 80			8.56	97.18	179	205	834	22.665	
SCH 160			13.49	87.32	293	336	1378	34.053	
R141.30X6.55-316-A999 R141.30X9.53-316-A999 R141.30X15.88-316-A999	5"	141.30	SCH 40	6.55	128.20	108	123	501	22.101
SCH 80			9.53	122.24	160	183	745	31.444	
SCH 160			15.88	109.54	277	318	1304	49.871	
R168.28X3.40-316 R168.28X7.11-316-A999 R168.28X18.26-316-A999	6"	168.28	SCH 10	3.40	161.48	46	53	212	14.039
SCH 40			7.11	154.08	98	112	454	28.697	
SCH 160			18.26	131.78	267	306	1254	68.603	
R219.08X8.18-316 R219.08X23.01-316-A999	8"	219.08	SCH 40	8.18	202.74	87	99	399	43.202
SCH 160			23.01	173.08	258	296	1209	112.981	

Other sizes on request!

Seamless EO tube bends 90° Material E235N (St. 37.4) and 1.4571

For minimum pressure loss

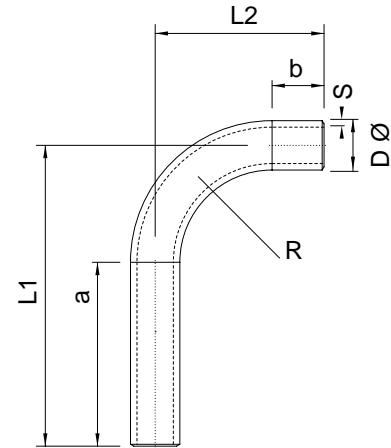

Order code			Tube O.D. D	Tolerance ±	Wall- thickness S	Tube I.D. mm	Bending radius R	Leg length		Length		Weight kg/piece
St. 37.4 phosphated	Cr(VI)-free	1.4571						a	b	L1	L2	
RB16X2	RB16X2CF	RB16X271	16	0.08	2.0	12	30	200	40	230	70	0.198
RB18X1.5	RB18X1.5CF	RB18X1.571	18	0.08	1.5	15	36	200	35	236	71	0.178
RB20X2	RB20X2CF		20	0.08	2.0	16	36	200	45	236	81	0.268
RB20X2.5	RB20X2.5CF	RB20X2.571	20	0.08	2.5	15	36	200	45	236	81	0.326
RB22X1.5	RB22X1.5CF		22	0.08	1.5	19	38	200	40	238	78	0.227
RB22X2	RB22X2CF	RB22X271	22	0.08	2.0	18	38	200	40	238	78	0.296
RB25X2	RB25X2CF		25	0.08	2.0	21	44	200	50	244	94	0.362
RB25X2.5	RB25X2.5CF	RB25X2.571	25	0.08	2.5	20	44	200	50	244	94	0.442
RB25X3	RB25X3CF		25	0.08	3.0	19	44	200	50	244	94	0.519
RB28X1.5	RB28X1.5CF		28	0.08	1.5	25	48	200	50	248	98	0.319
RB28X2	RB28X2CF	RB28X271	28	0.08	2.0	24	48	200	50	248	98	0.417
RB28X3	RB28X3CF		28	0.08	3.0	22	48	200	50	248	98	0.601
RB30X2.5	RB30X2.5CF		30	0.08	2.5	25	50	200	60	250	110	0.575
RB30X3	RB30X3CF	RB30X371	30	0.08	3.0	24	50	200	60	250	110	0.677
RB30X4	RB30X4CF		30	0.08	4.0	22	50	200	60	250	110	0.869
RB35X2	RB35X2CF	RB35X271	35	0.15	2.0	31	60	200	65	260	125	0.586
RB35X3	RB35X3CF		35	0.15	3.0	29	60	200	65	260	125	0.852
RB38X2.5	RB38X2.5CF		38	0.15	2.5	33	65	200	75	265	140	0.827
RB38X3	RB38X3CF		38	0.15	3.0	32	65	200	75	265	140	0.979
RB38X4	RB38X4CF	RB38X471	38	0.15	4.0	30	65	200	75	265	140	1.268
RB38X5	RB38X5CF		38	0.15	5.0	28	65	200	75	265	140	1.538
RB42X2	RB42X2CF	RB42X271	42	0.20	2.0	38	80	200	85	280	165	0.809
RB42X3	RB42X3CF		42	0.20	3.0	36	80	200	85	280	165	1.183
RB50X6			50	0.20	6.0	38	180	150	150	330	330	3.496
RB65X8			65	0.30	8.0	49	180	160	160	330	330	6.294

Conversion tables

Temperature conversion table

Celsius to Fahrenheit

°C	°F
150	302
145	293
140	284
135	275
130	266
125	257
120	248
115	239
110	230
105	221
100	212
95	203
90	194
85	185
80	176
75	167
70	158
65	149
60	140
55	131
50	122
45	113
40	104
35	95
30	86
25	77
20	68
15	59
10	50
5	41
0	32
-5	23
-10	14
-15	5
-20	-4
-25	-13
-30	-22
-35	-31
-40	-40
-45	-49
-50	-58

Fahrenheit to Celsius

°F	°C
340	171
330	166
320	160
310	154
300	149
290	143
280	138
270	132
260	127
250	121
240	116
230	110
220	104
210	99
200	93
190	88
180	82
170	77
160	71
150	66
140	60
130	54
120	49
110	43
100	38
90	32
80	27
70	21
60	16
50	10
40	4
30	-1
20	-7
10	-12
0	-18
-10	-23
-20	-29
-30	-34
-40	-40
-50	-46
-60	-51

Pressure conversion table

bar to psi

bar	psi
1000	14505
800	11604
600	8703
500	7253
400	5802
250	3626
160	2321
100	1451
60	870
40	580
35	508
25	363
16	232
10	145
6	87
4	58
2.5	36
1.6	23
1	15

psi to bar

psi	bar
10000	689
9000	620
7000	483
6000	414
4000	276
3000	207
2500	172
1000	69
900	62
600	41
500	34
400	28
250	17
150	10.3
100	6.9
90	6.2
60	4.1
40	2.8
25	1.7
10	0.7

Examples

Temperature conversion

Initial value: 100

°C to °F: 212 °F

°F to °C: 37,78 °C

Pressure conversion

Initial value: 35

bar to psi: 507.675 psi

psi to bar: 2.41296 bar

Tube clamps

DIN 3015

Programme:

Tube clamps series A (according to DIN 3015 Part 1)

Available in seven standard sizes for normal mechanical requirements.

- **Outer tube diameter for the metric series 6 to 57 mm**
- **Outer tube diameter for the inch-size series R 1/8" to R 1 1/2"**
- **Outer tube diameter for the imperial size series 1/4" to 2 1/2"**

The clamp body is available in a round/closed version.

Welding plates, rail-supports, cover plates and construction types.

Tube clamps series B (according to DIN 3015 Part 3)

Available as a twin tube clamp in five standard sizes for normal mechanical requirements.

Outer tube diameter 6 to 42 mm.

The clamp body is available in a square/open design.

Welding plates, rail-supports, cover plates and construction types.

Clamp halves with different diameters are only possible when used together.

Tube clamps series C (according to DIN 3015 Part 2)

Specially designed for high mechanical requirements, and available in eight standard sizes.

- **Outer tube diameter 6 to 220 mm.**

The clamp body is available in a square/closed design.

Welding plates, rail-supports, cover plates and construction types.

Design:

According to DIN 3015:

Both upper and lower clamp-halves are identical.

Webs inside the bore of the clamps provide an impact and vibration deadening effect, and absorb the forces towards the direction of the tube axis.

When using hoses and cables, we recommend the use of clamp halves with a smooth bore.

Clamp material:

Polypropylene	-30°C up to	+ 90° C	colour dark green
Polyamide	-40°C up to	+ 120° C	colour black
Rubber	-50°C up to	+ 120° C	colour black
Aluminium	up to	+ 300° C	

All metal parts available also in stainless steel.

Other materials upon request.

Stainless steel qualities

Stainless steel 1.4401/1.4571 (AISI 316/316 TI), resistant against rust and acid.

Accessories material:

Steel. Screws as well as cover plates of series A and B are galvanized.

Rail-supports are also available with zinc plated surface.

Resistance to stress:

The remarkable features of Tube Clamps are their considerable re-set capability, high tensile strength, as well as their very high output strength and excellent resistance to cold. The choice of design and clamp material depends on the specific demands of the mechanical and thermal requirements.

Tube clamps

Tube clamps material properties

DIN 3015

Mechanical properties		Polypropylene (PP)	Polyamide 6 (PA 6)	Aluminium	Rubber
Density		0.906 g/cm ³	1.12–1.15g/cm ³	2.65 g/cm ³	0.98 g/cm ³
Flexural deflection	DIN 53452	36 N/mm ²	130...200 N/mm ²	70 N/mm ²	–
Impact resistance	DIN 53453	no break	no break	–	–
Compressive strength	DIN 53454	90 N/mm ²	120 N/mm ²	HB 500...600 N/mm ²	A and B: 64° shore C: 73° shore
Modulus of elasticity	DIN 53452	1500 N/mm ²	3000 N/mm ²	70.000 N/mm ²	–
Tensile strength					A and B: 6.1 N/mm ²
without breakage	DIN 53454	25–35 N/mm ²	80–90 N/mm ²	180 N/mm ²	C: 8.5 N/mm ²

Thermal properties					
Temp. resistance		–30 ... + 90°C	–40 ... + 120°C	300°C	–50 ... +120°C

Chemical properties					
Weak acids		limited resistant	limited resistant		resistant
Weak alkalis		limited resistant	limited resistant		resistant
Alcohol		resistant	resistant		resistant
Petrol		limited resistant	resistant		limited resistant
Mineral oils		resistant	resistant		resistant
Other oils		resistant	resistant		resistant

The outlined particulars are approximate values and are only shown for reference, which are not binding, and with regard to possible protection of third parties. They do not exempt you from your own examination of suitability of the products delivered by us. Therefore, these values can only be used in a limited way for guidance only.

The application of the products is carried out outside of our control and, therefore, is exclusively subject to your own area of responsibility. Any claim however would be limited for all damages to the value of the goods supplied by us and in use by you.

It goes without saying, that we guarantee the perfect quality of our products according to our general sales and delivery conditions.

Tube clamps assembly instruction

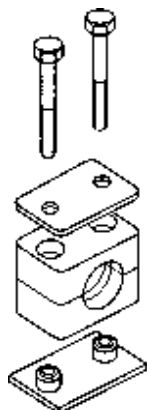

Assembly on to metal welding plates

Place welding plates on a base appropriate for the load. Make sure that the clamps are properly aligned. Clamp lower clamp half onto welding plate, insert tube, place upper clamp half onto lower half and fasten with the screws. Attention must be paid to the bias (after completed assembly, clamp halves may not be in contact)! Do not weld with fitted plastic clamp! Extended welding plates may be screw-fastened to the base.

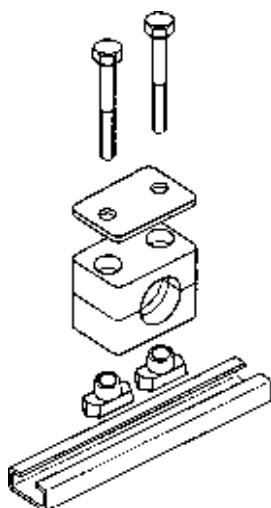

Assembly on support rails

Support rails are available in four different heights and come in pieces of 1 m or 2 m length, as required. Weld on support rail or screw-fasten with fastening angle bracket. Insert support rail nuts in rail and turn until stoppage. For heavy duty construction series, nuts are simply pushed in. Clamp lower clamp half on support rail nuts, insert tube, place upper clamp half onto lower half and fasten with the screws. Before fastening the screws the clamp may still be positioned. Attention must be paid to the bias (after completed assembly, the clamp halves may not be in contact)!

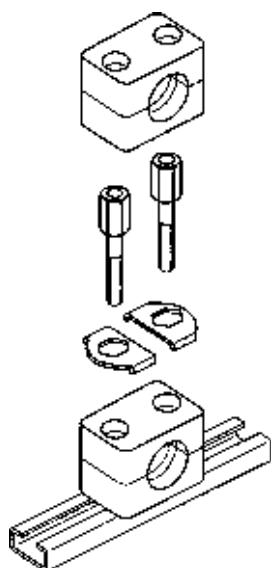

Construction assembly

Clamps allow the assembly of multiple clamps of the same construction size and of different tube diameters one above the other. The construction assembly is carried out with special fixing screws that are secured against twisting by applying a locking plate. Clamp lower clamp half on welding plate or support rail respectively, insert tube, place upper clamp half on lower half and fasten with fixing screws. The fixing screw juts out from the upper clamp half. The application of a locking plate securely fastens the fixing screw and prevents twisting. Clamp on second clamp half on to the fixing screws etc.

Tube clamps

Tube clamps

DIN 3015

Screw tightening torque and axial pipe shearing forces

The indicated screw tightening torque and axial pipe shearing forces refer to the assembly with cover plates and outside hexagon bolts according to DIN 931/933.

The axial pipe shearing force (according to DIN 3015, part 10) is an average value, determined by three tests made with a steel pipe according to DIN 2448 of St. 37, for which static friction is assumed (temperature during tests: 23°C).

When loading the clamp with the indicated test force (F) in axial pipe direction, the pipe must not slide in the clamp.

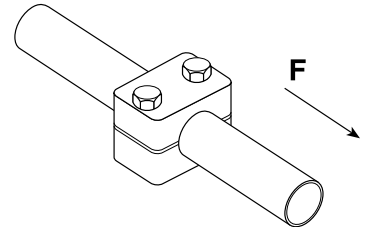

Light series (DIN 3015, part 1)

Size	Fixing screw DIN 931/933	Polypropylene		Polyamide		Aluminium	
		Screw tightening torque (Mn)	Pipe shearing force F (kN)	Screw tightening torque (Mn)	Pipe shearing force F (kN)	Screw tightening torque (Mn)	Pipe shearing force F (kN)
0	M6	8	0.6	10	0.6	–	–
1	M6	8	1.1	10	0.7	12	4.2
2	M6	8	1.2	10	0.8	12	4.3
3	M6	8	1.4	10	1.6	12	4.8
4	M6	8	1.5	10	1.7	12	5.0
5	M6	8	1.9	10	2.0	12	7.3
6	M6	8	2.0	10	2.5	12	8.9

Heavy series (DIN 3015, part 2)

Size	Fixing screw DIN 931/933	Polypropylene		Polyamide		Aluminium	
		Screw tightening torque (Mn)	Pipe shearing force F (kN)	Screw tightening torque (Mn)	Pipe shearing force F (kN)	Screw tightening torque (Mn)	Pipe shearing force F (kN)
1	M10	12	1.6	20	4.2	30	12.1
2	M10	12	2.9	20	4.5	30	15.1
3	M10	15	3.3	25	5.1	35	15.5
4	M12	30	8.2	40	9.3	55	29.4
5	M16	45	11.0	55	15.8	120	34.8
6	M20	80	14.0	150	21.0	220	50.0
7	M24	110	28.0	200	32.0	250	70.6
8	M30	180	40.0	350	48.0	500	84.5

Double series (DIN 3015, part 3)

Size	Fixing screw DIN 931/933	Polypropylene		Polyamide	
		Screw tightening torque (Mn)	Pipe shearing force F (kN)	Screw tightening torque (Mn)	Pipe shearing force F (kN)
1	M6	5	0.9	5	0.9
2	M8	12	2.1	12	2.2
3	M8	12	1.9	12	2.0
4	M8	12	2.7	12	2.9
5	M8	8	1.7	8	2.5

Tube clamps

DIN 3015

Recommended clamp pitch

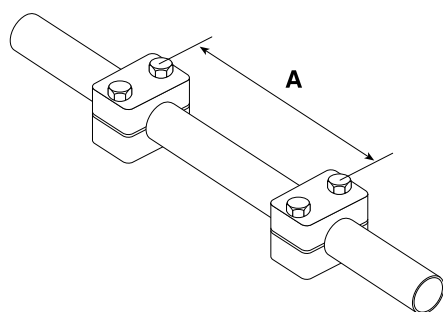

The clamp pitches corresponding to respective outside pipe diameters are standard for static loads.

Pipe bend assembly

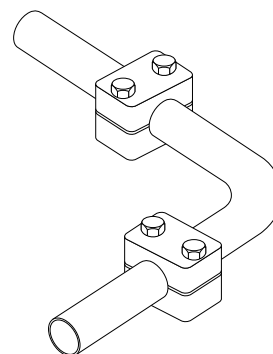

Pipe bends must be fixed with pipe clamps immediately in front of and behind the bend.

Outside pipe diameter (mm)	Clamp pitch A (m)
6.0 – 12.7	1.0
12.7 – 22.0	1.2
22.0 – 32.0	1.5
32.0 – 38.0	2.0
38.0 – 57.0	2.7
57.0 – 75.0	3.0
75.0 – 76.1	3.5
76.1 – 88.9	3.7
88.9 – 102.0	4.0
102.0 – 114.0	4.5
114.0 – 168.0	5.0
168.0 – 219.0	6.0

Tube clamps

Tube clamps series A (Light construction series) – Components

DIN 3015, part 1

Order code for clamp halves:

- Polypropylene – **STANDARD**
- Inside smooth – **GLAD**
- Polyamide 6 – **PA**
- Inside smooth – **PAGLAD**
- Rubber – **RUB**
- Aluminium – **ALU**

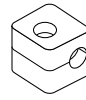

size 0

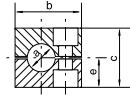

size 0

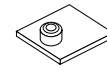

size 0

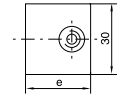

size 0

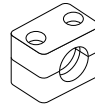

size 1-8

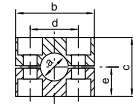

size 1-8
Width: 30 mm

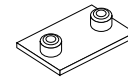

size 1-8

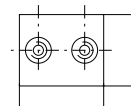

size 1-8
Thickness:
3 mm

clamp size	Tube O.D. mm a	Tube NB	Tube O.D.	1 part 2 clamp halves				welding plate, short				
				Order code	dimensions: b c d e				Order code	dimensions: d e		
0	6.0	G 1/8	1/4	390000	28	27	-	13.5	390999	-	30	
	6.4											390032
	8.0											390001
	9.5											390034
	10.0											390002
	12.0											390003
1	6.0	G 1/8	1/4	390004	34	27	20	13.5	390998	20	36	
	6.4											390035
	8.0											390005
	9.5											390037
	10.0											390006
	12.0											390007
2	12.7	G 1/4	1/2	390038	42	33	26	16.5	390997	26	42	
	13.5											390025
	14.0											390008
	15.0	G 3/8	5/8	390009	42	33	26	16.5	390997	26	42	
	16.0											390010
	17.2											390026
18.0	390011											
3	19.0	G 1/2	3/4	390040	49	35	33	17.5	390996	33	50	
	20.0											390012
	21.3											390027
	22.0											390013
	23.0											390014
	25.0											390015
4	26.9	G 3/4	1	390028	59	42	40	21	390995	40	59	
	28.0											390016
	30.0											390017
5	32.0	G 1	1 1/4	390018	71	58	52	29	390994	52	72	
	33.7											390029
	35.0											390019
	38.0	G 1 1/4	1 1/2	390020	71	58	52	29	390994	52	72	
	40.0											390021
	42.0											390022
6	44.5	G 1 1/2	1 3/4	390050	86	66	66	33	391000	66	88	
	45.0											390044
	48.0											390045
	50.0											390046
	50.8	2	2 1/4	390051	86	66	66	33	391000	66	88	
	52.0											390047
	55.0											390048
	57.0											390052

Continued on next page...

Tube clamps series A (Light construction series) – Components (Continued)

DIN 3015, part 1

Order code for clamp halves:

Polypropylene – **STANDARD**
 Inside smooth – **GLAD**
 Polyamide 6 – **PA**
 Inside smooth – **PAGLAD**
 Rubber – **RUB**
 Aluminium – **ALU**

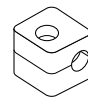

size 0

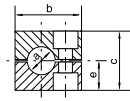

size 0

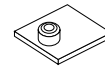

size 0

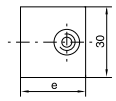

size 0

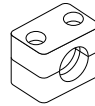

size 1-8

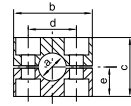

size 1-8
Width: 30 mm

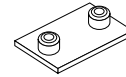

size 1-8

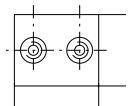

size 1-8
Thickness:
3 mm

clamp size	Tube O.D. mm a	Tube NB	Tube O.D.	1 part 2 clamp halves				welding plate, short			
				Order code	dimensions: b c d e			Order code	dimensions: d e		
7	57.2	G 2	2 1/4	390060	121	93.6	94	46.8	391007	94	122
	60.3			390061							
	63.5			390062							
	70.0			390063							
	73.0		390064								
	76.1	G 2 1/2	3	390065							
8	88.9	G 3	4	390070	147	117.6	120	58.8	391008	120	148
	101.8			390071							

When assembling solid rubber clamps, covering plates, hexagon screws and locking washers must be used.

All metal parts available in stainless steel, please add suffix **RVS** after partnumber if stainless steel is required.

1) Aluminium only sizes 1 to 6.

Order code suffixes					
	Smooth	Polyamide	Polyamide smooth	Rubber	Aluminium
Suffix	GLAD	PA	PAGLAD	RUB	ALU
Example	390010GLAD	390010PA	390010PAGLAD	390010RUB	390010ALU

Tube clamps

Tube clamps series A (Light construction series) – Components

DIN 3015, part 1

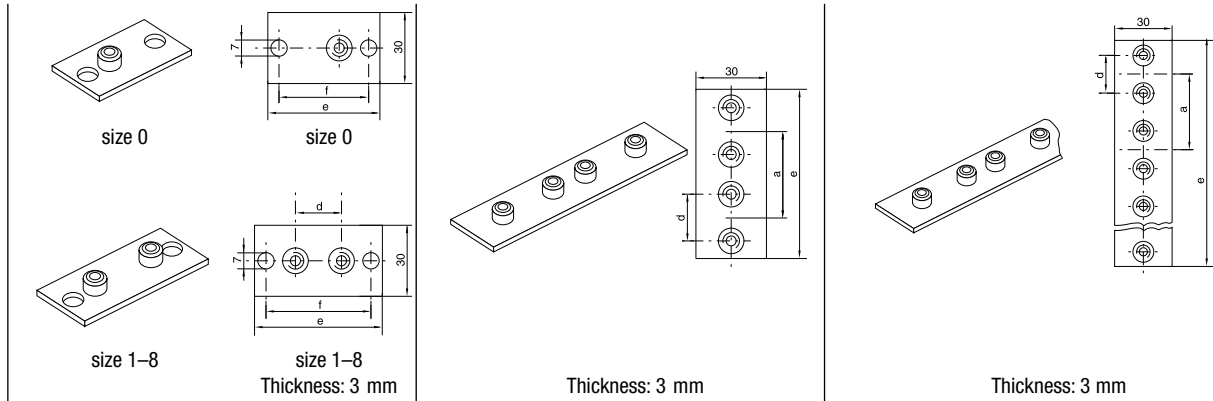

clamp size	weld/screw plate, long			twin welding plate			multiple weld plate					
	Order code	dimensions:			Order code	dimensions:			Order code	dimensions:		
		d	e	f		d	a	e		d	a	e
0	390993	–	58	44	390987	–	30	61	390981 (10 clamps)	–	30	298
1	390992	20	64	50	390986	20	35	69	390980 (10 clamps)	20	35	349
2	390991	26	70	56	390985	26	43	86	390979 (10 clamps)	26	43	427
3	390990	33	78	64	390984	33	52	104	390977 (10 clamps)	33	52	516
4	390989	40	87	73	390983	40	60	117	390975 (5 clamps)	40	60	297
5	390988	52	100	86	390982	52	75	145	390974 (5 clamps)	52	75	370
6	391001	66	116	100	391002	66	90	176	391003 (5 clamps)	66	90	446
7	391004	94	150	136								
8	391005	120	178	162								

All metal parts available in stainless steel, please add suffix **RVS** after partnumber if stainless steel is required.

Tube clamps series A (Light construction series) – Components

DIN 3015, part 1

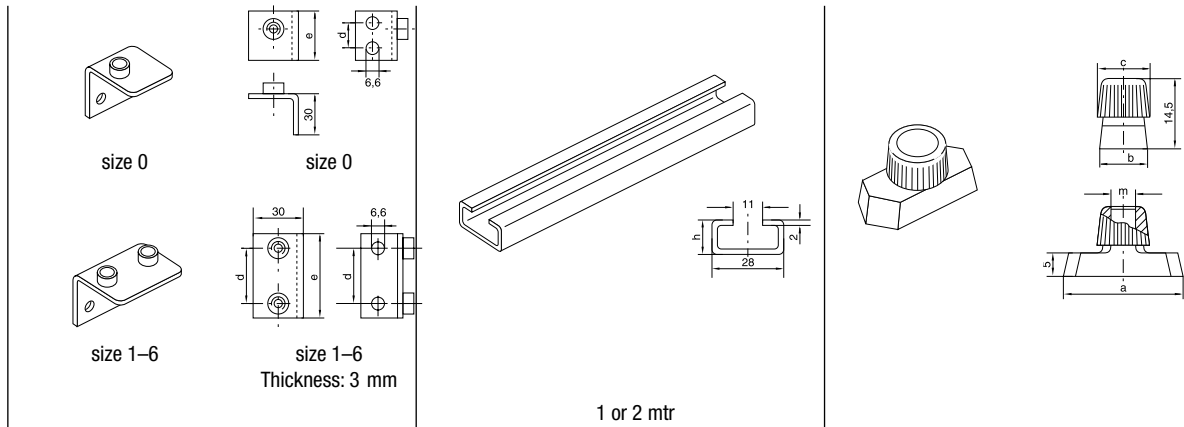

clamp size	weld plate, angled		mounting rail		rail nut				
	Order code	dimensions: d e	Order code	dimensions: h	Order code	dimensions: a b c m			
0	390899	14 30	390914 390915	14 30	390904	25.4	10.4	12	M6
1	390898	20 36							
2	390897	26 42							
3	390896	33 50							
4	390895	40 59							
5	390894	52 72							
6	391800	66 88							

All metal parts available in stainless steel, please add suffix **RVS** after partnumber if stainless steel is required.

Tube clamps

Tube clamps series A (Light construction series) – Components

DIN 3015, part 1

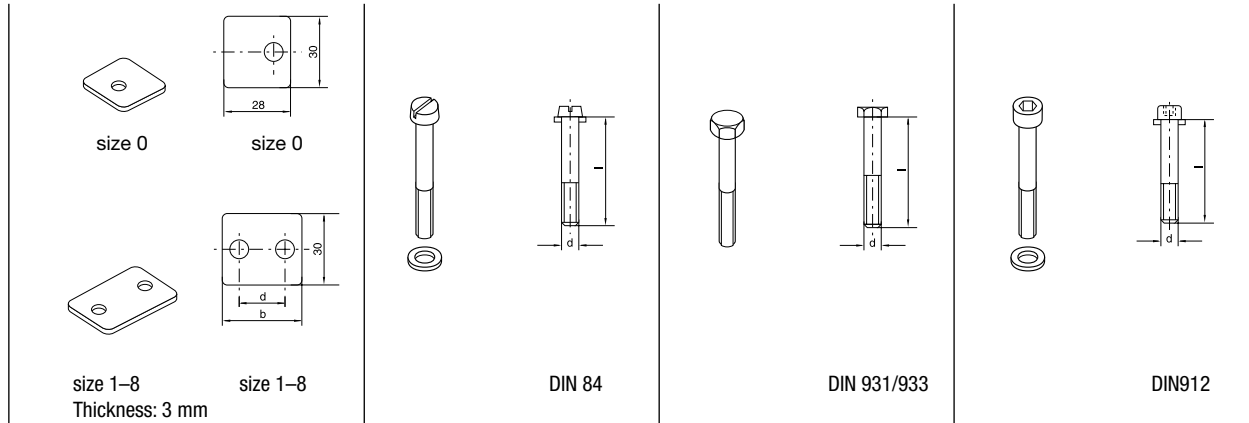

clamp size	cover plate		slot head		hexagon head		socket head	
	Order code	dimensions: b d	Order code	dimensions: d × L	Order code	dimensions: d × L	Order code	dimensions: d × L
0	390952	– –	090040	M 06×20	090091	M 06×30	090001	M 06×20
1	390951	34 20	090040	M 06×20	090091	M 06×30	090001	M 06×20
2	390950	40 26	090050	M 06×25	090101	M 06×35	090011	M 06×25
3	390949	48 33	090060	M 06×30	090111	M 06×40	090021	M 06×30
4	390948	57 40	090070	M 06×35	090121	M 06×45	089271	M 06×35
5	390947	70 52	090080	M 06×50	090131	M 06×60	090031	M 06×50
6	391043	86 66	090081	M 06×60	090082	M 06×70	090032	M 06×60
7	391044	120 94			090092	M 06×100		
8	391045	146 120			090093	M 06×125		

All metal parts available in stainless steel, please add suffix **RVS** after partnumber if stainless steel is required.

Tube clamps series A (Light construction series) – Components

DIN 3015, part 1

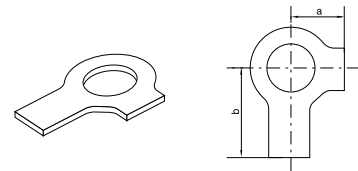
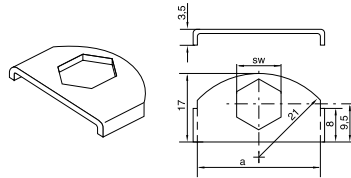
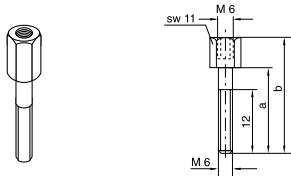

clamp size	stacking ¹⁾		locking plate ¹⁾			locking washer ²⁾		
	Order code	dimensions: a b	Order code	dimensions: a SW	Order code	dimensions: a b		
0	090270	20 34						
1	090270	20 34						
2	090280	25 39						
3	090290	30 44	390925	30 11	090600	9 18		
4	090300	35 49						
5	090310	50 64						
6	090361	60 74						

¹⁾ The use of stacking bolts necessitates the use of locking plates in the construction assembly.

²⁾ When assembling solid rubber clamps, cover plates, hexagon screws and locking washers must be used.

All metal parts available in stainless steel, please add suffix **RVS** after partnumber if stainless steel is required.

Tube clamps series B (Twin-tube clamps) – Components

DIN 3015, part 3

Order code for clamp halves:

Polypropylene – **STANDARD**
 Inside smooth – **GLAD**
 Polyamide 6 – **PA**
 Rubber – **RUB**

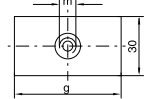
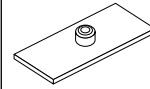
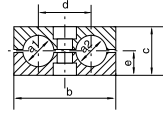
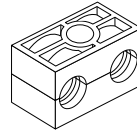

Width: 30 mm

clamp size	Tube O.D. mm	Tube NB	Tube O.D.	1 part 2 clamp halves ¹⁾				weld plate			
				Order code	b	c	d	e	Order code	g	m
1	6.0	G 1/8	1/4	390200	36	27	20	13.5	390957	37	M6
	6.4			390235							
	8.0			390201							
	9.5			390237							
	10.0			390202							
	12.0			390203							
2	12.7	G 1/4	1/2	390238	53	26	29	13	390956	55	M8
	13.5			390225							
	14.0			390204							
	15.0			390205							
	16.0			390206							
	17.2			390226							
18.0	390207										
3	19.0	G 1/2	3/4	390219	67	37	36	18.5	390955	70	M8
	20.0			390208							
	21.3			390227							
	22.0			390209							
4	25.0	G 3/4	1	390210	82	42	45	21	390954	85	M8
	26.9			390228							
	28.0			390211							
5	30.0	G 1	1 1/4	390212	106	54	56	27	390953	110	M8
	32.0			390218							
	33.7			390220							
	35.0			390213							
	38.0			390214							
42.0	390215										

All metal parts available in stainless steel, please add suffix **RVS** after partnumber if stainless steel is required.

¹⁾ Twin-tube clamps with different outer tube diameters upon request.

Order code suffixes			
	Smooth	Polyamide	Rubber
Suffix	GLAD	PA	RUB
Example	390206LAD	390206PA	390206RUB

Tube clamps series B (Twin-tube clamps) – Components

DIN 3015, part 3

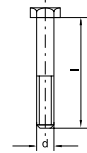
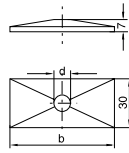
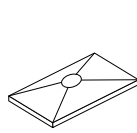

DIN 931/933

clamp size	cover plate		hexagonal head	
	Order code	dimensions: b d	Order code	dimensions: d × L
1	390930	34 6.6	090101	M 06×35
2	390929	51 8.6	090231	M 08×35
3	390928	64 8.6	090241	M 08×45
4	390927	78 8.6	090251	M 08×50
5	390926	102 8.6	090261	M 08×60

All metal parts available in stainless steel, please add suffix **RVS** after partnumber if stainless steel is required.

Tube clamps series B (Twin-tube clamps) – Components

DIN 3015, part 3

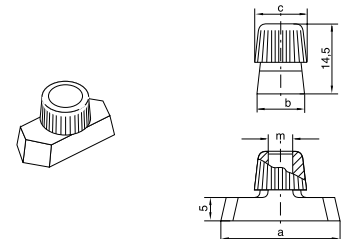
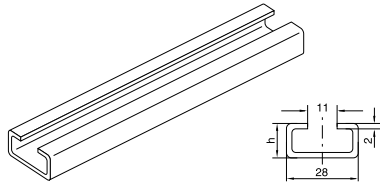
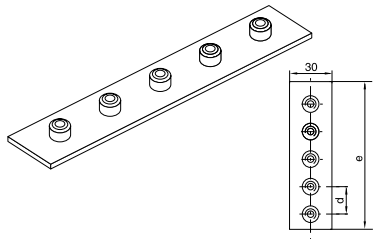

2 mtr

clamp size	weld plate, angled		mounting rail		rail nut				
	Order code	dimensions: d e Thickness:	Order code	dimensions: h	Order code	a	b	c m	
1	3909801 (5 clamps)	40 196 Thickness: 3 mm	390914 390913	14 30	390904	25.4	10.4	12 M6	
2	3909792 (5 clamps)	58 288 Thickness: 5 mm			390906	25.4	10.4	12 M8	
3	3909773 (5 clamps)	72 358 Thickness: 5 mm							
4	3909754 (5 clamps)	90 446 Thickness: 5 mm							
5	3909745 (5 clamps)	112 558 Thickness: 5 mm							

Tube clamps series B (Twin-tube clamps) – Components

DIN 3015, part 3

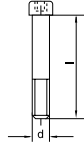

DIN 912

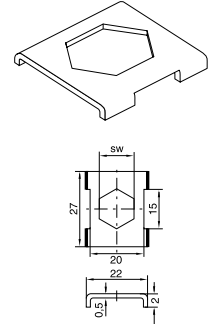
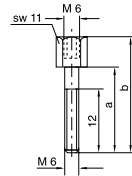
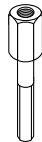

clamp size	socket head		Order code	stacking				locking plate ¹⁾	
	Order code	dimensions: d × L		a	b	m	SW	Order code	dim.: SW
1	089271	M 06×35	090270	20	34	M6	11	390919	11
2	089261	M 08×35	090330	20	33	M8	12	390918	12
3	089251	M 08×45	090340	29	44	M8	12		
4	089241	M 08×50	090350	34	49	M8	12		
5	089231	M 08×60	090360	47	62	M8	12		

¹⁾ The use of stacking screws necessitates the use of locking plates in the construction assembly!

²⁾ When assembling solid rubber clamps, covering plates, hexagon screws and locking washers must be used. All metal parts available in stainless steel, please add suffix **RVS** after partnumber if stainless steel is required.

Tube clamps series C (Heavy series) – Components

DIN 3015, part 2

Order code for clamp halves:

Polypropylene – **STANDARD**
 Inside smooth – **GLAD**
 Polyamide 6 – **PA**
 Rubber – **RUB**
 Aluminium – **ALU**

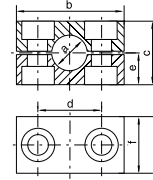
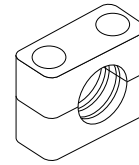

clamp size	Tube O.D. mm	Tube NB	Tube O.D.	Order code	1 part 2 clamp halves				
					dimensions:				
					b	c	d	e	f
1	6.0	G 1/8	5/16	390099	55	32	33	16	30
	8.0			390100					
	10.0			390101					
	12.0			390102					
	12.7	390168							
	13.5	G 1/4	1/2	390103					
	14.0			390104					
	15.0			390105					
	16.0	G 3/8	5/8	390106					
	17.2			390107					
18.0	390108								
2	19.0	G 1/2	3/4	390167	70	48	45	24	30
	20.0			390109					
	21.3			390110					
	22.0			390111					
	23.0	390112							
	25.0	G 3/4	1	390113					
	26.9			390114					
	28.0			390115					
	30.0	390116-2							
	3	30.0	G 1	1 1/4					
32.0		390117							
33.7		390118							
35.0		390119							
38.0		G 1 1/4	1 1/2	390120					
40.0				390121					
42.0				390122					
4	38.0	G 1 1/4	1 1/2	390123	115	90	90	45	45
	40.0			390124					
	42.0			390125					
	45.0			390126					
	48.3	G 1 1/2	2	390127					
	50.0			390128					
	51.0			390129					
	52.0	G 2	2 1/4	390130					
	55.0			390131					
	57.0			390132					
	60.3			390133					
	63.0	2 1/2	2 1/2	390134					
	65.0			390135					
	70.0			390136					

Continued on next page...

Tube clamps series C (Heavy series) – Components (Continued)

DIN 3015, part 2

Order code for clamp halves:

- Polypropylene – **STANDARD**
- Inside smooth – **GLAD**
- Polyamide 6 – **PA**
- Rubber – **RUB**
- Aluminium – **ALU**

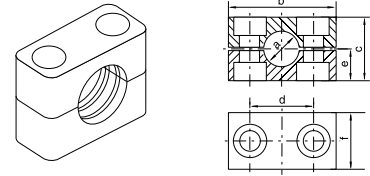

clamp size	Tube O.D. mm	Tube NB	Tube O.D.	Order code	1 part 2 clamp halves					
					dimensions:					
					b	c	d	e	f	
5	70.0	G 2 1/2	3	390137	152	120	122	60	60	
	73.0			390166						
	75.0			390165						
	76.1			390138						
	80.0			390164						
	82.5	G 3	3 1/4	390139						
	88.9		3 1/2	390140						
	90.0		390141-5							
6	90.0	G 3 1/2	4	390141	205	170	168	85	80	
	97.0			390163						
	100.0			390162						
	101.6	G 4	4 1/4	390142						
	108.0			390143						
	114.3			4 1/2						390144
	127.0			5						390145
7	127.0	G 5	5	390147	250	200	205	100	90	
	133.0			5 1/4						390148
	140.0			5 1/2						390149
	150.0	G 5 1/2	6	390160						
	152.4			390150						
	159.0			6 1/4						390151
	165.1			6 1/2						390152
	168.3			6 5/8						390153
8	168.3	G 8	6 5/8	390154	320	270	265	135	120	
	177.8		7	390155						
	193.7		7 5/8	390156						
	203.0		390159							
	219.1		390157							
	220.0		390158							

Order code suffixes				
	Smooth	Polyamide	Rubber	Aluminium
Suffix	GLAD	PA	RUB	ALU
Example	390106GLAD	390106PA	390106RUB	390106ALU

Tube clamps series C (Heavy series) – Components

DIN 3015, part 2

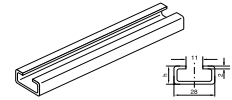
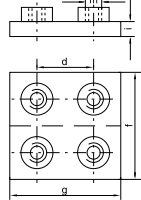
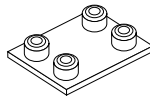
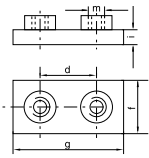
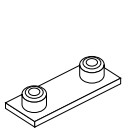

Clamp size	weld plate dimensions:						double weld plate dimensions:						mounting rail dimensions:		
	Order code	d	f	g	i	m	Order code	d	f	g	i	m	Order code	b	h
1	390973	33	30	73	8	M10	390965	33	60	73	8	M10	390201	40	22
2	390972	45	30	85	8	M10	390964	45	60	85	8	M10			
3	390971	60	30	100	8	M10	390963	60	60	100	8	M10			
4	390970	90	45	140	10	M12	390962	90	90	140	10	M12			
5	390969	122	60	180	10	M16	390961	122	120	180	10	M16			
6	390968	168	80	225	15	M20	390960	168	160	225	15	M20			
7	390967	205	90	270	15	M24	390959	205	180	270	15	M24			
8	390966	265	120	340	25	M30	390958	265	240	340	25	M30			

All metal parts available in stainless steel, please add suffix **RVS** after partnumber if stainless steel is required.

Tube clamps series C (Heavy series) – Components

DIN 3015, part 2

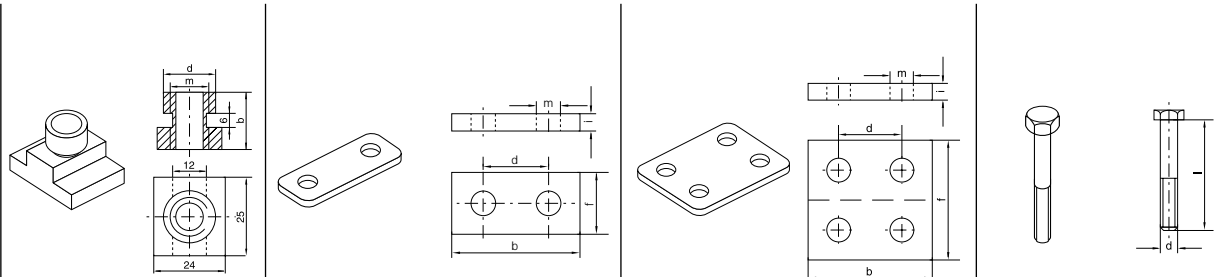

DIN 931/933

clamp size	rail nut			cover plate					double cover plate					hexagon head				
	Order code	dimensions:			Order code	dimensions:					Order code	dimensions:					Order code	dimensions:
		b	d	m		b	d	f	i	m		b	d	f	i	m		d × L
1	390907	20	17.8	M10	390946	55	33	30	8	11	390938	55	33	60	8	11	090141	M 10×40
2					390945	70	45	30	8	11	390937	70	45	60	8	11	090151	M 10×60
3					390944	85	60	30	8	11	390936	85	60	60	8	11	090161	M 10×70
4	390908	23	19.8	M12	390943	115	90	45	10	14	390935	115	90	90	10	14	090401	M 12×100
5					390942	152	122	60	10	18	390934	152	122	120	10	18	090181	M 16×130
6					390941	205	168	80	15	22	390933	205	168	160	15	22	090191	M 20×190
7					390940	250	205	90	15	26	390932	250	205	180	15	26	090201	M 24×220
8					390939	320	265	120	25	33	390931	320	265	240	25	33	090211	M 30×300

All metal parts available in stainless steel, please add suffix **RVS** after partnumber if stainless steel is required.

Tube clamps series C (Heavy series) – Components

DIN 3015, part 2

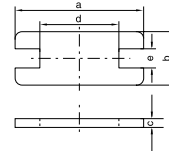
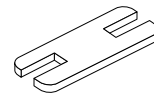
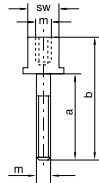

clamp size	stacking dimensions:					locking plate ¹⁾ dimensions:					
	Ordercode	a	b	m	SW	Ordercode	a	b	c	d	e
1	090510	25	51	M10	15	390510	55	30	8	14	15.5
2	090520	40	66	M10	15	390520	70	30	8	26	15.5
3	090530	50	76	M10	15	390530	85	30	8	41	15.5
4	090540	85	112	M12	17	390540	115	45	10	69	17.5
5	090550	110	146	M16	21	390550	152	60	10	97	21.5
6	090560	155	206	M20	27	390560	205	80	15	137	27.5
7	090570	185	245	M24	30	390570	250	90	15	169	30.5
8	090580	250	330	M30	36	390580	320	120	25	219	36.5

¹⁾ The use of stacking screws necessitates the use of locking plates in the construction assembly!

²⁾ When assembling solid rubber clamps, covering plates, hexagon screws and locking washers must be used.

All metal parts available in stainless steel, please add suffix **RVS** after partnumber if stainless steel is required.

Tube clamps series O

Areas of Application:

- pneumatics
- automotive technology
- machine tool industry
- lubrication
- naval technologie

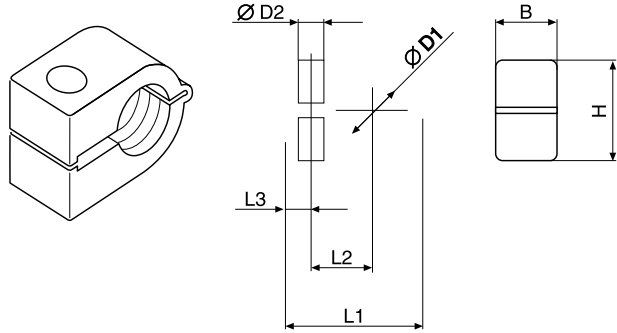

Clamp size	O.D. mm	Tube Ø D1		Order code Polypropylene	Order code Polyamide	L1	L2	L3	B	H	Ø D2
		Tube NB	Inch								
1	6.0		1/4	392001	392001PA	22	9	7	14.5	13.5	6.5
	6.4			392002	392002PA						
	8.0			392003	392003PA						
2	8.0	1/8	3/8	392004	392004PA	27	11	7	14.5	18.5	6.5
	9.5			392005	392005PA						
	10.0			392006	392006PA						
	12.0			392007	392007PA						
	12.7	392008	392008PA								
3	10.0	1/8	1/2	392009	392009PA	33	15	7	14.5	23.5	6.5
	12.0	1/4		392010	392010PA						
	12.7			392011	392011PA						
	13.5	5/8	392012	392012PA							
	14.0		392013	392013PA							
	15.0		392014	392014PA							
16.0		392015	392015PA								
4	14.0	3/8	5/8	392016	392016PA	40	19	6	14.5	30.5	6.5
	15.0			392017	392017PA						
	16.0			392018	392018PA						
	17.2			392019	392019PA						
	18.0			392020	392020PA						
	19.0	3/4	392021	392021PA							
	20.0		392022	392022PA							
	21.3		1/2	392023	392023PA						
	22.0	392024		PA392024							

Double-Tube clamps series O

Areas of Application:

- pneumatics
- automotive technology
- machine tool industry
- lubrication
- naval technologie

Material: Galvanized steel
Stainless steel upon request

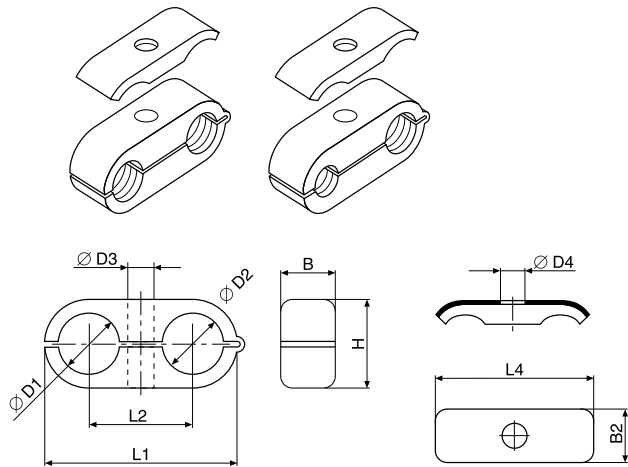

Clamp size	Tube Ø D1/D2		Inch	Order code Polypropylene	Order code Cover plate	L1	L2	B	H	Ø D3	L4	B2	Ø D4
	O.D. mm	Tube NB											
1	6.0		1/4	392201	392930	32	18	14.5	13.5	6.5	29.0	16.3	6.5
	6.4			392202									
	8.0			392203									
2	8.0	1/8	3/8	390204	392929	41	22	14.5	18.5	6.5	40.0	16.3	6.5
	9.5			392205									
	10.0			392206									
	12.0			392207									
	12.7			392208									
3	10.0	1/8	1/2	392209	392928	54	30	14.5	23.5	6.5	50.5	16.5	6.5
	12.0	1/4		392210									
	12.7			392211									
	13.5			392212									
	14.0			392213									
	15.0			392214									
16.0	5/8	392215											
4	14.0	3/8	5/8	392216	392927	69	38	14.5	30.5	6.5	63.0	16.5	6.5
	15.0			392217									
	16.0			392218									
	17.2			392219									
	18.0			392220									
	19.0	3/4	392221										
	20.0	1/2	392222										
	21.3		392223										
	22.0		392224										

Hydraulic steel-clamps

Hydraulic steel-clamps

HSRS hydraulic steel-clamps are mainly used in the field of building machinery.

The support-block is welded to the machine body or another component either in upend or flat position. The tube-clamp is screwed on.

The robust construction of the clamp has an impact- and vibrationabsorbing effect. The small dimension/height of the clamp allows hydraulic cables to be fitted later on – e. g. for installing additional equipment to building machinery.

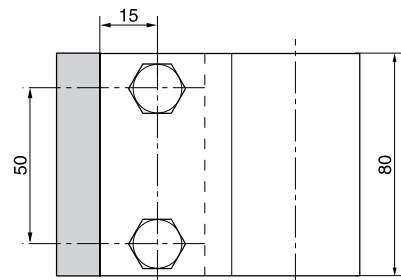
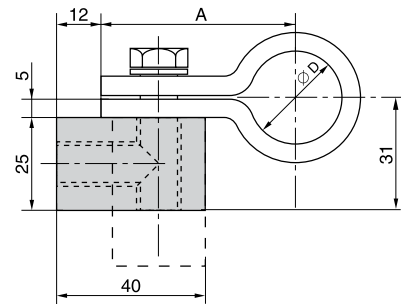
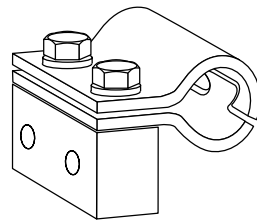
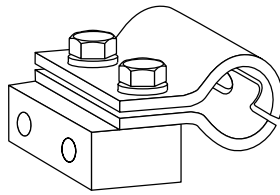

Order code	Measurement	
	Ø D	A
HSRS25	25	52.5
HSRS30	30	55.0
HSRS35	35	57.5
HSRS38	38	59.0
HSRS42	42	61.0
HSRS50	50	65.0

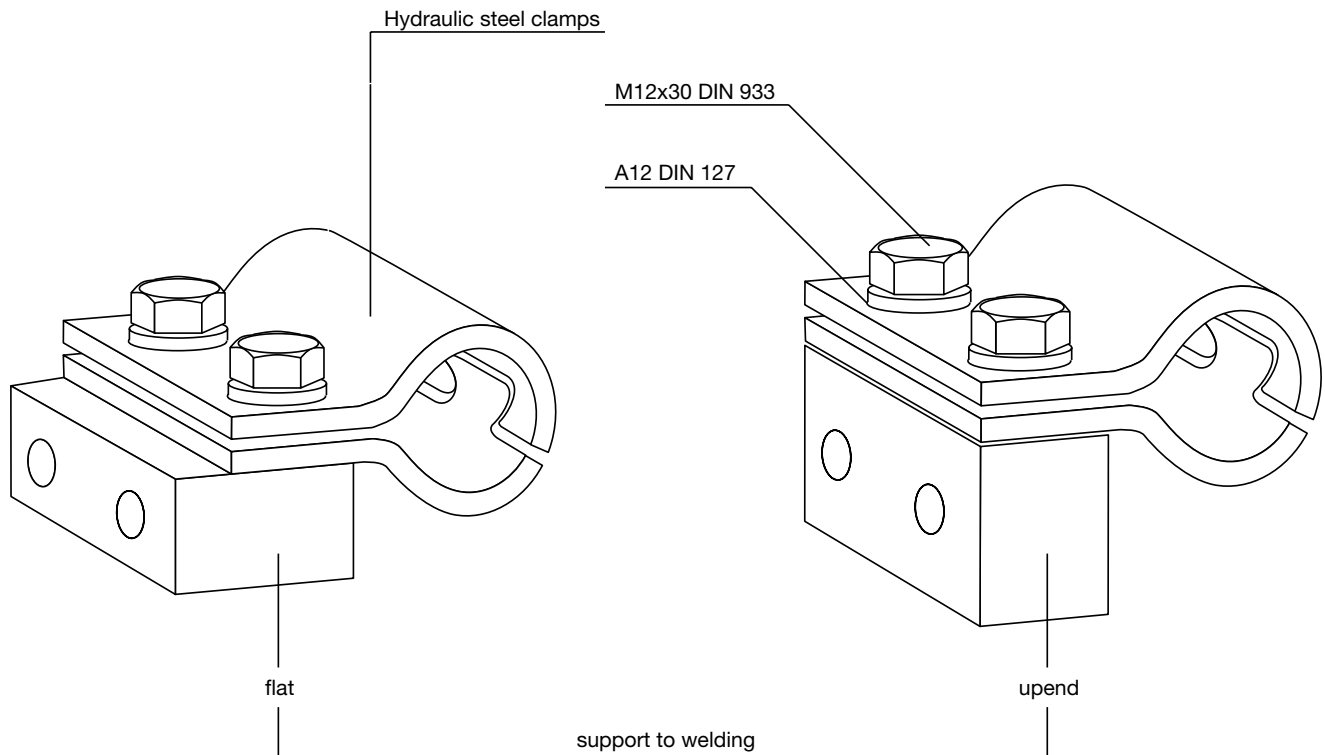

Hydraulic steel-clamps

Elastomere Inlay for HSRS

Hydraulic steel tube clamp **HSRS** also available with Elastomere inlay

The advantages:

- complete outside tube diameter
- Safe fastening method even for very sensitive tube and hoses lines
- Only one clamp for different tube diameters

Material:

Santoprene 64 Shore

- high oil and weathering resistance
- temperature stability between -40°C and $+125^{\circ}\text{C}$

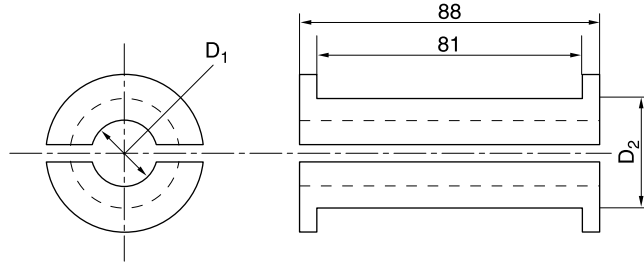

Order code	Nominal size D2	mm O.D. D1
EE12X	HSRS25	12
EE15X		15
EE20X	HSRS30	20
EE25X	HSRS35	25
EE30X	HSRS42	30
EE35X	HSRS50	35
EE38X		38
EE42X		42

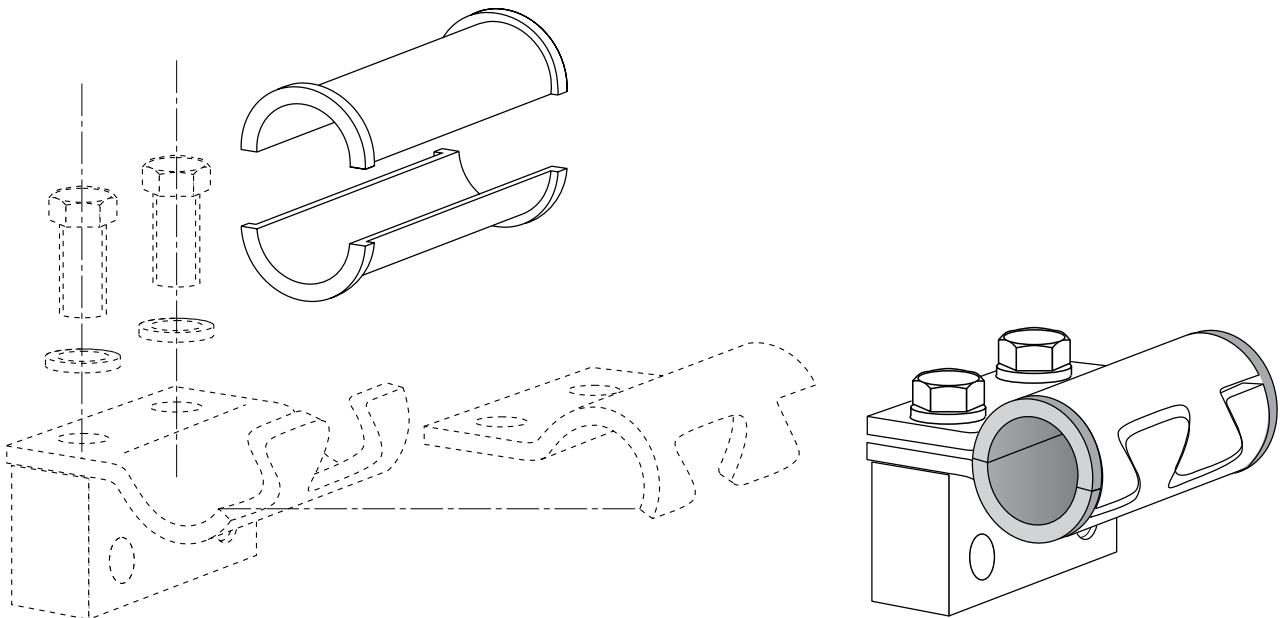

Tube Clamps with Elastomer Inlay

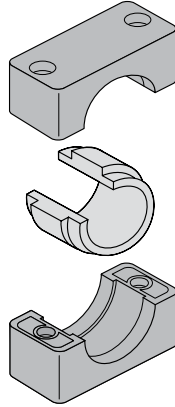

Clamp size		Tube O.D. mm	Series A Clamp body with elastomer inlay	Series C Clamp body with elastomer inlay	Elastomer inlay
Serie A	Serie C				
4	2	6.0	394004E	395099E	EE206/406X
		8.0	394005E	395100E	EE208/408X
		10.0	394006E	395101E	EE210/410X
		12.0	394007E	395102E	EE212/412X
		12.7	394038E		EE212.7/412.7X
		14.0	394008E	395104E	EE214/414X
		15.0	394009E	395105E	EE215/415X
		16.0	394010E	395106E	EE216/416X
		17.2	394026E	395107E	EE217.2/417.2X
		18.0	394011E	395108E	EE218/418X
		19.0	394040E		EE219/419X
6	3	20.0	394012E	395109E	EE320/620X
		21.3	394027E	395110E	EE321.3/621.3X
		22.0	394013E	395111E	EE322/622X
		23.0	394014E	395112E	EE323/623X
		25.0	394015E	395113E	EE325/625X
		26.9	394028E	395114E	EE326.9/626.9X
		28.0	394016E	395115E	EE328/628X
		30.0	394017E	395116E	EE330/630X
		32.0	394018E		EE332/632X
	4	32.0		395117E	EE432X
		33.7		395118E	EE433.7X
		35.0		395119E	EE435X
		38.0		395120E	EE438X
		40.0		395121E	EE440X
		42.0		395125E	EE442X
		45.5			EE445.5X
		48.0			EE448X
		51.0			EE451X
		53.4			EE453.4X
56.4			EE456.4X		

Attention! For clamps with elastomer inlay, the relation of diameter and size is not identical with the profile design or smooth design.

Tube clamps series 2+5 (Light construction series)

DIN 3015, Part 1, Components

Order code for clamp halves:

Polypropylene – **STANDARD**
 Inside smooth – **GLAD**
 Polyamide 6 – **PA**
 Rubber – **RUB**
 Aluminium – **ALU**



Size 2

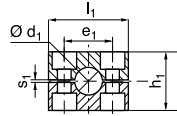

Size 2

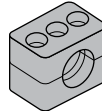

Size 5

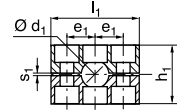

Size 5

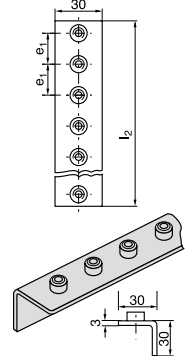
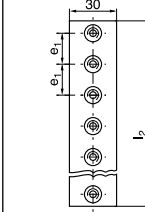

Clamp size	O.D. mm	Tube NB	Inch O.D.	1 part	2 clamp-halves	Multiple weld plate		Multiple weld plate, angled						
	d ₁			Order code	l ₁	h ₁	e ₁	s ₁	e ₁	l ₂	e ₁	l ₂		
2	6.0	G 1/8	1/4	393004	40	33	26	0.8	26	508	26	508		
	6.4		393035											
	8.0		393005											
	9.5		393037											
	10.0		393006											
	12.0	393007												
	12.7	G 1/4	1/2	393038										
	13.5	393025												
	14.0	393008												
	15.0	393009												
	16.0	393010												
5	17.2	G 3/8	5/8	393026	70	58	26	1.2	26	508	26	508		
	18.0			393011										
	19.0	G 1/2	3/4	393040									390978	393979
	20.0			393012										
	21.3			393027										
	22.0			393013										
	23.0			393014										
	25.0	G 3/4	1	393015										
	26.9			393028										
	28.0			393016										
	30.0	G 1	1 1/4	393017										
32.0	393018													
33.7	393029													
35.0	393019													
38.0	393020													
40.0	G 1 1/4	1 1/2	393021											
42.0			393022											

When assembling solid rubber clamps, cover plates, hexagon screws and locking washers must be used.
 All metal parts available in stainless steel, please add suffix **RVS** after partnumber if stainless steel is required.

Order code suffixes				
	Smooth	Polyamide	Rubber	Aluminium
Suffix	GLAD	PA	RUB	ALU
Example	393010GLAD	393010PA	393010RUB	393010ALU

Tube clamps series 2+5 (Light construction series)

DIN 3015, Part 1, Components

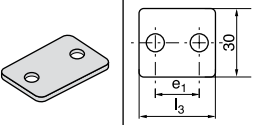
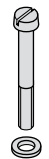
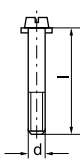
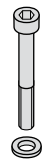
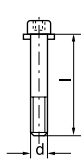
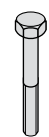
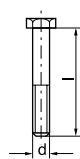
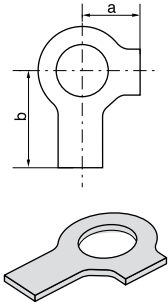
Cover plate	Bolts		Bolts		Bolts		Locking washer ¹⁾		
	Slot head	Slot head	Socket head	Socket head	Hexagon head	Hexagon head	a	b	
									
	ISO 1207 (DIN 84)		ISO 4762 (DIN 912)		ISO 4014/4017 (DIN 931/933)				
390950	40	26	090050	M 06×25	090011	M 06×25	090101	M 06×25	
390947	70	52	090080	M 06×50	090031	M 06×50	090131	M 06×60	9 090600 18

¹⁾ When assembling solid rubber clamps, cover plates, hexagon screws and locking washers must be used.

Valves

9011-.. - 2-way BSPP brass ball valve

BSPP Female thread, long threaded

Connection : Female thread
 Material : Brass
 Surface treatment : Nickel plated
 Operation : Lever
 Handle material : Steel
 Handle colour : Yellow
 Seal material : PTFE
 Working temperature : -20 °C to + 150 °C

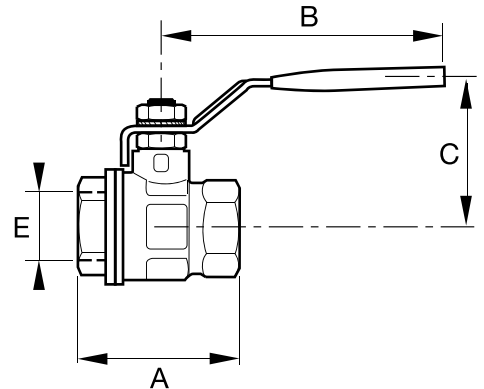

Size	A (mm)	B (mm)	C (mm)	E (inch)	ND (mm)	Order code	PN (bar)
1/2	56.2	95.5	45	G 1/2	14.5	9011-08	40
3/4	68	115.5	57	G 3/4	19.5	9011-12	40
1	78	115.5	65	G 1	24.5	9011-16	30
1 1/4	90	131	79	G 1 1/4	32	9011-20	30
1 1/2	102	163	82	G 1 1/2	39.5	9011-24	25
2	123	163	95	G 2	49.5	9011-32	25

9011-..Z - 2-way BSPP brass ball valve heavy

BSPP Female thread, long threaded

Connection : Female thread
 Material : Brass
 Surface treatment : Nickel plated
 Operation : Lever
 Handle material : Steel
 Handle colour : Black
 Seal material : PTFE
 Working temperature : -20 °C to + 170 °C

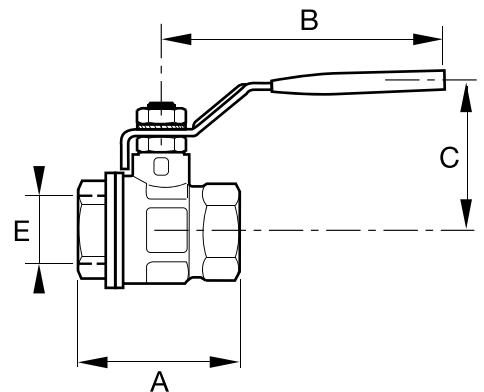

Size	A (mm)	B (mm)	C (mm)	E (inch)	ND (mm)	Order code	PN (bar)
1/4	51	28	40	G 1/4	8	9011-04Z	65
3/8	51	28	40	G 3/8	10	9011-06Z	65
1/2	61	34	42	G 1/2	15	9011-08Z	65
3/4	74,5	44	52	G 3/4	20	9011-12Z	40
1	90,5	52	57	G 1	25	9011-16Z	40
1 1/4	104	65	70	G 1 1/4	32	9011-20Z	40
1 1/2	117	80	78	G 1 1/2	40	9011-24Z	40
2	135	96	87	G 2	50	9011-32Z	40

9012-.. - Gate valve with cast handwheel

BSPP Female thread

Connection : Female thread
 Material : Brass
 Operation : Handwheel
 Handle material : Cast iron
 Handle colour : Red
 Plate material : Brass
 Working temperature : 0°C to + 170 °C

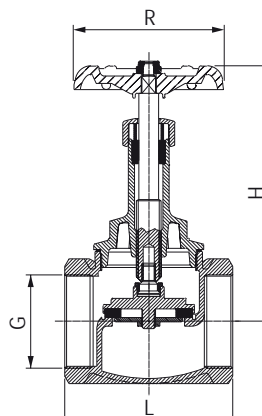

Size	L (mm)	H (mm)	R (mm)	G (inch)	ND (mm)	Order code	PN (bar)
1/2	50	77,5	55	G 1/2	12,5	9012-08	16
3/4	60	89	60	G 3/4	16,0	9012-12	16
1	70	98,5	65	G 1	21,5	9012-16	16
1 1/4	85	112,7	65	G 1 1/4	26,5	9012-20	16
1 1/2	90	133	75	G 1 1/2	32,0	9012-24	16
2	110	141	80	G 2	41,0	9012-32	16
2 1/2	135	208	120	G 2 1/2	58,0	9012-40	16
3	148	234,5	120	G 3	65,0	9012-48	16
4	190	288	175	G 4	94,5	9012-64	16

9013-.. - 2-way BSPP brass ball valve

BSPP Female thread

Connection : Female thread
 Material : Brass
 Surface treatment : Nickel plated
 Operation : Lever
 Handle material : Steel
 Handle colour : Red
 Seal material : PTFE
 Working temperature : -20 °C to + 150 °C

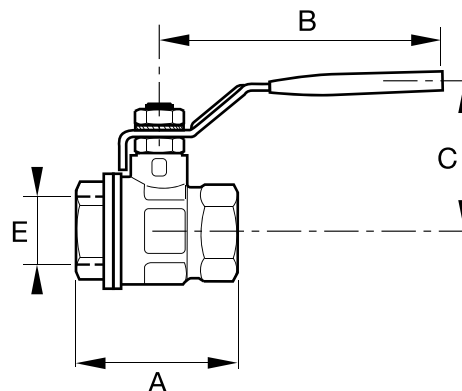

Size	A (mm)	B (mm)	C (mm)	E (inch)	ND (mm)	Order code	PN (bar)
1/4	40.5	86	42	G 1/4	9	9013-04	25
3/8	40.5	86	42	G 3/8	10	9013-06	25
1/2	48.5	100	46	G 1/2	15	9013-08	25
3/4	54.5	100	51.5	G 3/4	19	9013-12	25
1	66	125	54	G 1	24	9013-16	25
1 1/4	76	140	72	G 1 1/4	30	9013-20	25
1 1/2	88	140	78	G 1 1/2	37	9013-24	25
2	98.5	168	90	G 2	45	9013-32	25
2 1/2	132	226	110	G 2 1/2	62	9013-40	25
3	154	280	119	G 3	74	9013-48	25
4	179	280	130	G 4	90	9013-64	25

BVG4PLOCK - BSPP Female/Female, Vented, Locking Handle

BSPP Female thread, lockable vented valve with lever handle

Principle

Parker BVGPLOCK series of ball valves has been developed to meet the requirements of European Directive DI 89/392/CEE relating to the isolation of power supply and to meet the health and safety requirements for machines and materials in paragraphs L233-5 of the Code du Travail. **The BVGPLOCK series of ball valves incorporate two specific safety features :** An M5 threaded venting port enabling downstream pressure to be vented when the valve is closed. mechanism enabling the valve to be padlocked in the open position, thus preventing tampering or accidental closure of the valve during operation. All seals are treated with a silicone free lubricant enabling them to be used in water based paint spray applications.

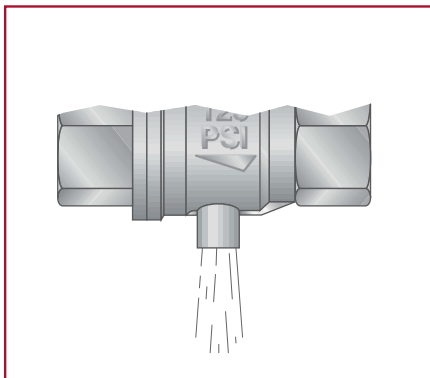
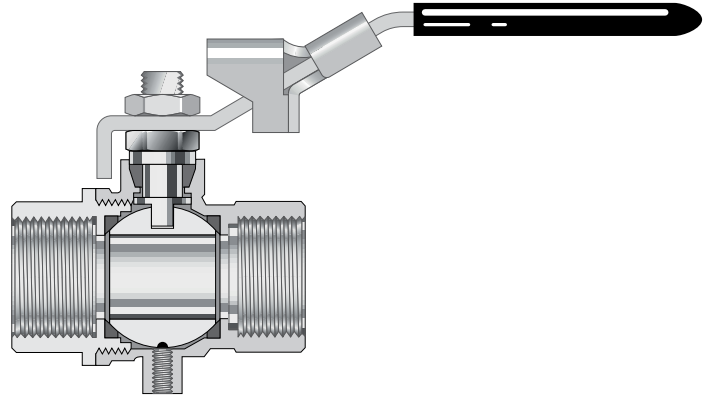

Threaded exhaust

BVGPLOCK series ball valves are manufactured with an M5 threaded exhaust port, this safety feature enables the downstream air pressure to be vented when the valve is closed.

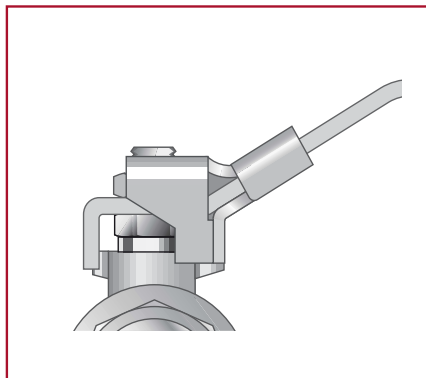

Lockable handle

The BVGPLOCK series ball valves are fitted with a handle that can be locked in the closed position with a padlock. This safety feature ensures the valve cannot be accidentally opened, and only authorised personnel can operate the valve

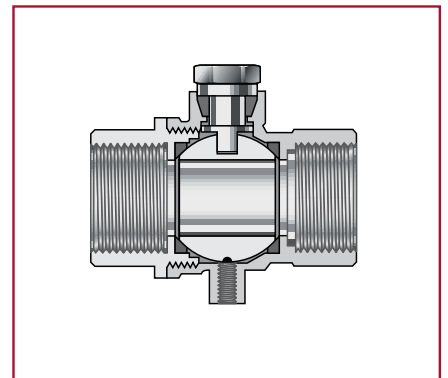

DIN 2999 / ISO 228 female threads

BVGPLOCK series valves are manufactured with female threads in accordance to DIN 2999/ ISO228. This enables the valves to be used with Prestolok, Metrulok and brass adaptors but also Parker's range of steel hydraulic fittings and EO-fittings form "A" or "C" to DIN 3852.

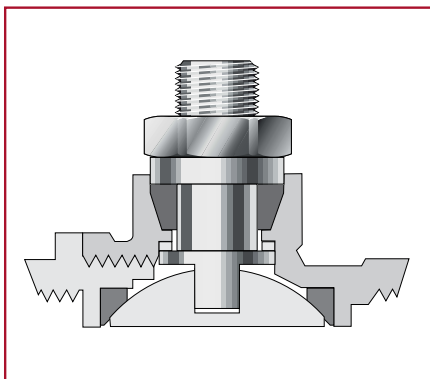

Anti extrusion stem

The BVGPLOCK series ball valves are fitted with an anti-extrusion stem to prevent blow out in the case of pressure peaks.

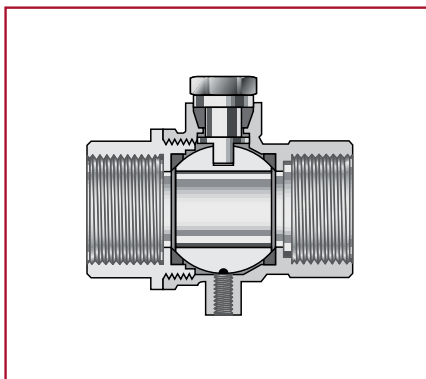

Full flow

All BVGPLOCK series valves are fullflow. This limits the turbulence created by the passage of fluid across the valve, minimizing pressure drop.

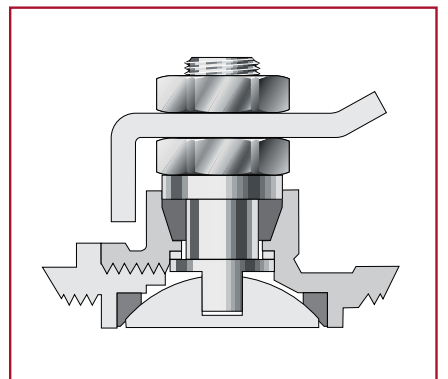

Adjustable packing

The PTFE packing gland and adjustable washer are designed to give longer service life and lower operating torques.

BVG4PLOCK - BSPP Female/Female, Vented, Locking Handle

BSPP Female thread, lockable vented valve with lever handle

Connection : Female thread
 Body : Brass nickel plated to DIN17660 and UNI5705 spec.
 Lever handle : Carbon steel with yellow PVC coating
 Anti-extrusion stem : Brass nickel plated
 Stem packing gland : PTFE
 Ball : Brass chrome plated
 Forcing nut : Brass nickel plated
 Working temperature : -20 °C to + 90 °C

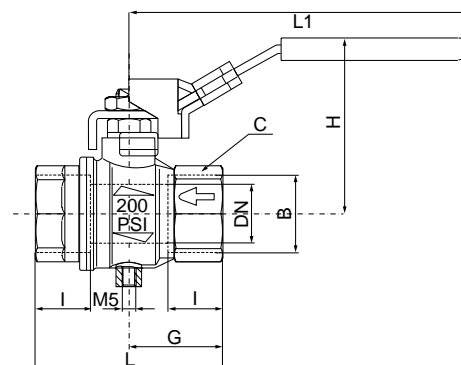

Size	C (mm)	G (mm)	H (mm)	I (mm)	L (mm)	L1 (mm)	DN (mm)	Order code	PN (bar)
1/4	20	22,5	47,5	12,0	45	96	8	BVG4P-1/4LOCK	13
3/8	20	22,5	47,5	12,0	45	96	10	BVG4P-3/8LOCK	13
1/2	25	29,5	52,0	15,5	59	96	16	BVG4P-1/2LOCK	13
3/4	31	32,0	59,5	17,0	64	117	20	BVG4P-3/4LOCK	13
1	40	40,5	63,5	21,0	81	117	25	BVG4P-1LOCK	13

MBVG series - BSPP short threads - Compact

BSPP Female thread

Principle

The MBVG series ball valves with their compact design offer the solution to applications where space is an important factor. The body is of a particularly robust design. The integrity of the sealing on the ball is obtained by the use of PTFE seats. The valves are available with BSPP female threads ISO-228/1 (DIN 299) in : 1/4" 3/8" and 1/2"

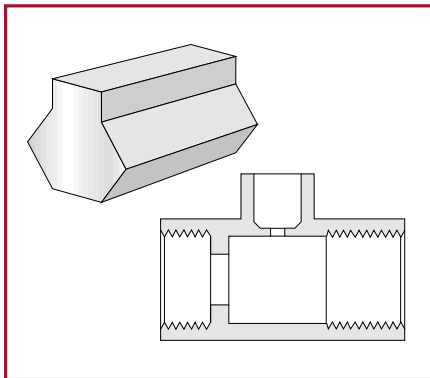
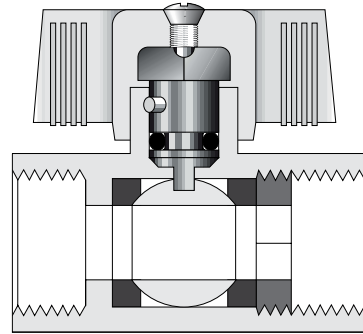

Design of the body

The valve is manufactured from a solid section which incorporates the stem housing in the body. This design allows excellent guidance of the stem, which increases its lifespan

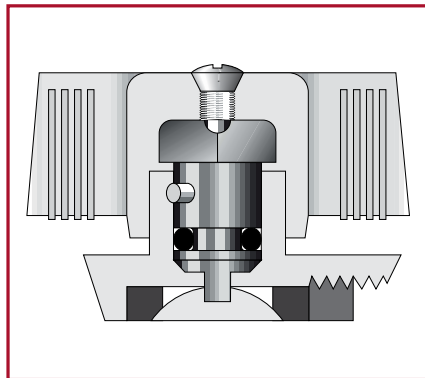

Stem tightness

A Fluorocarbon O-Ring assembled under compression automatically compensates for minute friction wear. Thus a high standard of seal is attained.

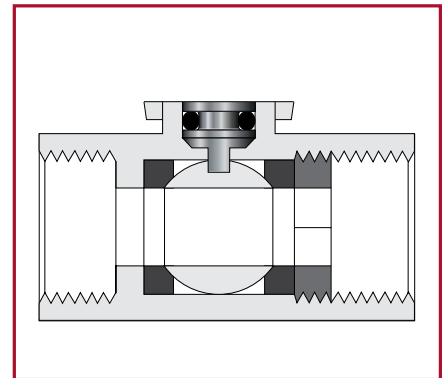

Tightness of the seals

The perfect tightness of the seals on the casing is obtained by the preset force of the nut, adjusted during assembly.

MBVG series - BSPP short threads - Compact

BSPP Female thread

Connection : Female thread
 Body : Brass chromium plated
 Handle retention screw : Brass chromium plated
 Stem : Brass
 Stem seal : Fluorocarbon
 Ball : Brass
 Anti-extrusion guide pin : Stainless chromium plated
 Seal material : PTFE
 Working temperature : -20 °C to + 90 °C

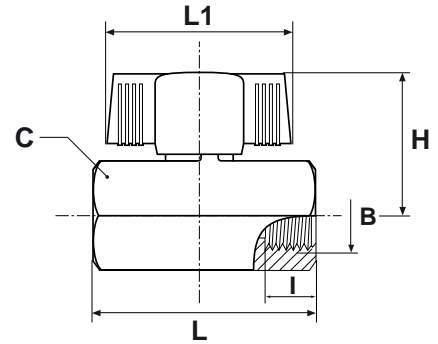

Size	C (mm)	H (mm)	L (mm)	L1 (mm)	I (mm)	DN (mm)	Order code	PN (bar)
1/4	21	31,5	41,5	39	11	8	MBVG4-1/4	13
3/8	21	31,5	41,5	39	11	8	MBVG4-3/8	13
1/2	25	33,5	48,0	39	13	10	MBVG4-1/2	13

9014-.. - 2-way BSPP ball valve

DIN ISO 228 BSPP Female thread

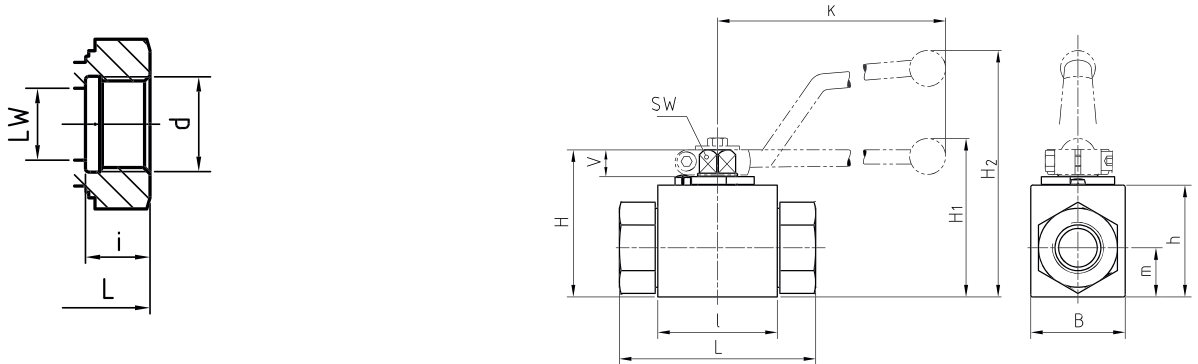

l	B	H	h	m	V	SW	K	H1	H2	LW	L	i	d	Weight kg/1 piece	Order code	PN (bar)
40	26	47	33	13,5	11	9	115	-	82	5	69	10	G 1/8	0,41	9014-02	500
40	26	47	33	13,5	11	9	115	-	82	6	69	14	G 1/4	0,40	9014-04	500
43	32	52	38	17,5	11	9	115	-	82	10	72	14	G 3/8	0,54	9014-06	500
48	35	54	40	19	11	9	115	-	82	13	83	16,3	G 1/2	0,65	9014-08	500
48	38	63	46	19	13	12	160	-	82	15	83	16	G 5/8	0,70	9014-10	420
62	49	75	57	24,5	14	14	200	79	-	20	95	18	G 3/4	1,50	9014-12	420
66	58	83	65	29,5	14	14	200	87	-	25	113	20	G 1	2,20	9014-16	315
74	70	88	70	34,5	14	14	200	92	-	25	113	20	G 1	3,10	9014-16-PN420	420
66	58	83	65	29,5	14	14	200	87	-	25	120	22	G 1 1/4	2,30	9014-20	315
66	58	83	65	29,5	14	14	200	87	-	25	130	24	G 1 1/2	2,60	9014-24	315

9015-.. - 2-way BSPP ball valve

ANSI B1.20.1 NPT Female thread

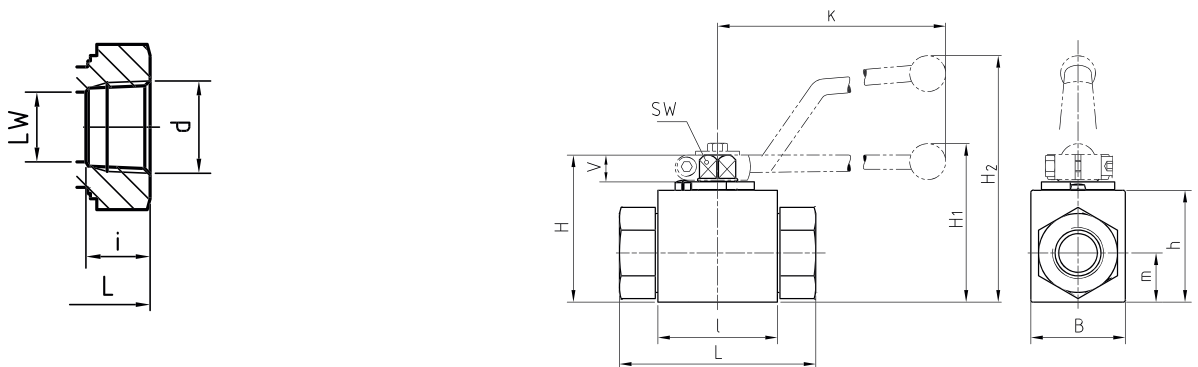

l	B	H	h	m	V	SW	K	H1	H2	LW	L	i	d	Weight kg/1 piece	Order code	PN (bar)
40	26	47	33	13,5	11	9	115	-	82	5	69	10,5	1/8 NPT	0,30	9015-02	500
40	26	47	33	13,5	11	9	115	-	82	6	69	13,7	1/4 NPT	0,40	9015-04	500
43	32	52	38	17,5	11	9	115	-	82	10	72	13,5	3/8 NPT	0,55	9015-06	500
48	35	54	40	19	11	9	115	-	82	13	83	17	1/2 NPT	0,75	9015-08	500
62	49	75	57	24,5	14	14	200	79	-	20	95	18,3	3/4 NPT	1,63	9015-12	420
66	58	83	65	29,5	14	14	200	87	-	25	113	21,6	1 NPT	2,30	9015-16	315
74	70	88	70	34,5	14	14	200	92	-	25	113	21,6	1 NPT	3,16	9015-16-PN420	420
66	58	83	65	29,5	14	14	200	87	-	25	120	22,1	1 1/4 NPT	2,51	9015-20	315
66	58	83	65	29,5	14	14	200	87	-	25	130	22,1	1 1/2 NPT	2,70	9015-24	250

9016-.. - 2-way Metric ball valve

DIN 2353 / ISO 8434-1 Light Series

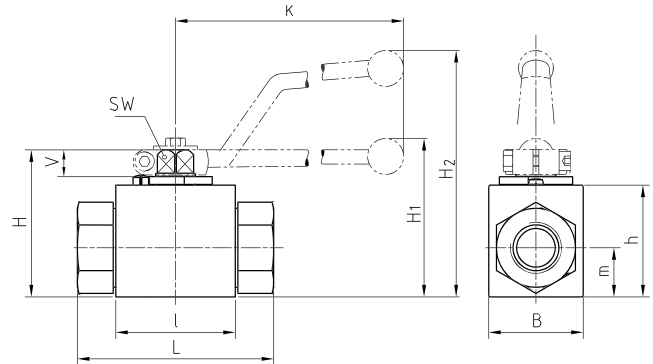
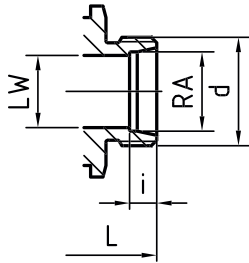

l	B	H	h	m	V	SW	K	H1	H2	LW	L	RA	i	d	Weight kg/1 piece	Order code	PN (bar)
40	26	47	33	13,5	11	9	115	-	82	5	67	6	7	M 12x1.5	0,36	9016-06	500
40	26	47	33	13,5	11	9	115	-	82	6	67	8	7	M 14x1.5	0,37	9016-08	500
40	26	47	33	13,5	11	9	115	-	82	8	74	10	7	M 16x1.5	0,38	9016-10	500
43	32	52	38	17,5	11	9	115	-	82	10	74	12	7	M 18x1.5	0,50	9016-12	500
48	35	54	40	19	11	9	115	-	82	13	82	15	7	M 22x1.5	0,61	9016-15	500
48	35	54	40	19	11	9	115	-	82	13	82	18	7,5	M 26x1.5	0,60	9016-18-DN13	500
48	38	63	46	19	13	12	160	-	82	15	82	18	7,5	M 26x1.5	0,75	9016-18	420
62	49	75	57	24,5	14	14	200	79	-	20	101	22	7,5	M 30x2.0	1,49	9016-22	420
66	58	83	65	29,5	14	14	200	87	-	25	108	28	7,5	M 36x2.0	2,00	9016-28	315
66	58	83	65	29,5	14	14	200	87	-	25	112	35	10,5	M 45x2.0	2,12	9016-35	315
66	58	83	65	29,5	14	14	200	87	-	25	112	42	11	M 52x2.0	2,27	9016-42	315

Please note the pressure ratings of the tube connections!

9017-.. - 2-way Metric ball valve

DIN 2353 / ISO 8434-1 Heavy Series

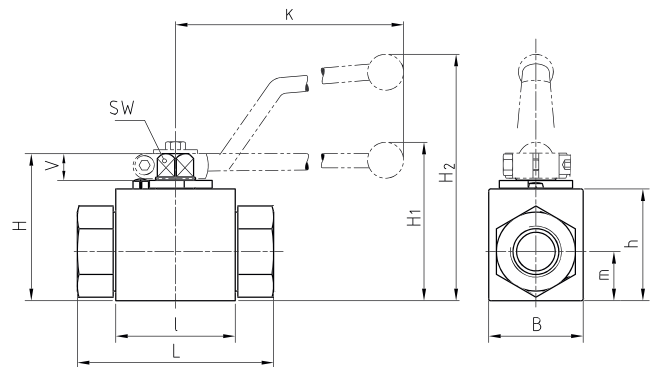
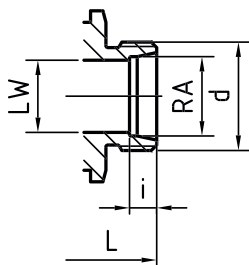

l	B	H	h	m	V	SW	K	H1	H2	LW	L	RA	i	d	Weight kg/1 piece	Order code	PN (bar)
40	26	47	33	13,5	11	9	115	-	82	5	73	8	7	M 16x1.5	0,36	9017-08	500
40	26	47	33	13,5	11	9	115	-	82	6	73	10	7,5	M 18x1.5	0,39	9017-10	500
40	26	47	33	13,5	11	9	115	-	82	8	76	12	7,5	M 20x1.5	0,39	9017-12	500
43	32	52	38	17,5	11	9	115	-	82	10	80	14	8	M 22x1.5	0,50	9017-14	500
48	35	54	40	19	11	9	115	-	82	13	86	16	8,5	M 24x1.5	0,60	9017-16	500
48	35	54	40	19	11	9	115	-	82	13	90	20	10,5	M 30x2.0	0,60	9017-20-DN13	500
48	38	63	46	19	13	12	160	-	82	15	90	20	10,5	M 30x2.0	0,80	9017-20	420
62	49	75	57	24,5	14	14	200	79	-	20	109	25	12	M 36x2.0	1,55	9017-25	420
66	58	83	65	29,5	14	14	200	87	-	25	120	30	13,5	M 42x2.0	2,10	9017-30	315
66	58	83	65	29,5	14	14	200	87	-	25	130	30	13,5	M 42x2.0	3,06	9017-30-PN420	420
66	58	83	65	29,5	14	14	200	87	-	25	124	38	16	M 52x2.0	2,30	9017-38	315

Please note the pressure ratings of the tube connections!

9018-.. - 2-way BSPP ball valve

DIN ISO 228 BSPP Female thread

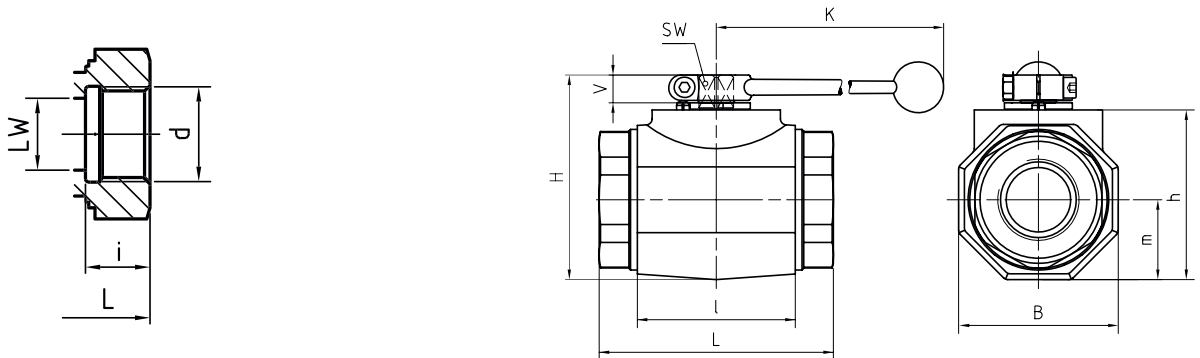

l	B	H	h	m	V	SW	K	LW	L	i	d	Weight kg/1 piece	Order code	PN (bar)
80	81	107	86	40,5	16,5	17	320	32	111	22	G 1 1/4	3,47	9018-20	420
85	100	124	103	50	16,5	17	320	38	130	24	G 1 1/2	5,67	9018-24	420
100	118	138	117	59	16,5	17	320	48	140	26	G 2	8,14	9018-32	420

9018-..NPT - 2-way NPT ball valve

ANSI B1.20.1 NPT Female thread

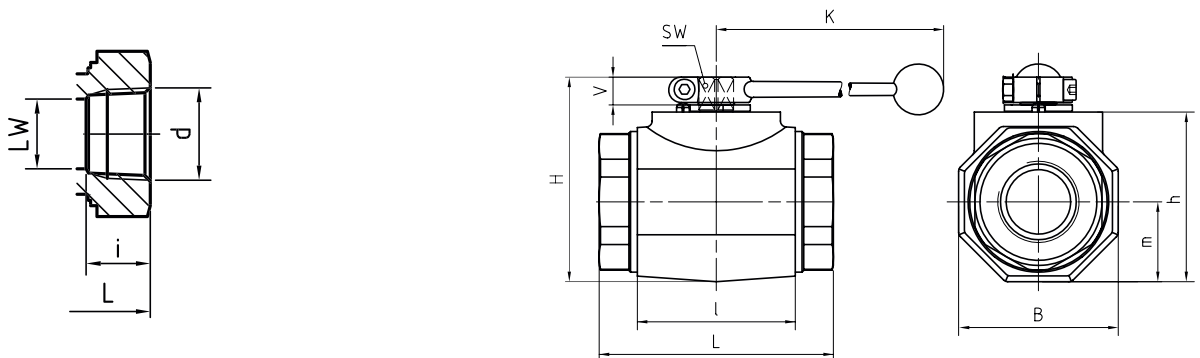

l	B	H	h	m	V	SW	K	LW	L	i	d	Weight kg/1 piece	Order code	PN (bar)
80	81	107	86	40,5	16,5	17	320	32	120	22,1	1 1/4 NPT	3,52	9018-20NPT	420
85	100	124	103	50	16,5	17	320	38	130	22,1	1 1/2 NPT	5,69	9018-24NPT	420
100	118	138	117	59	16,5	17	320	48	140	30,3	2 NPT	8,14	9018-32NPT	420

9019-.. - 2-way Metric ball valve

DIN 2353 / ISO 8434-1 Light Series

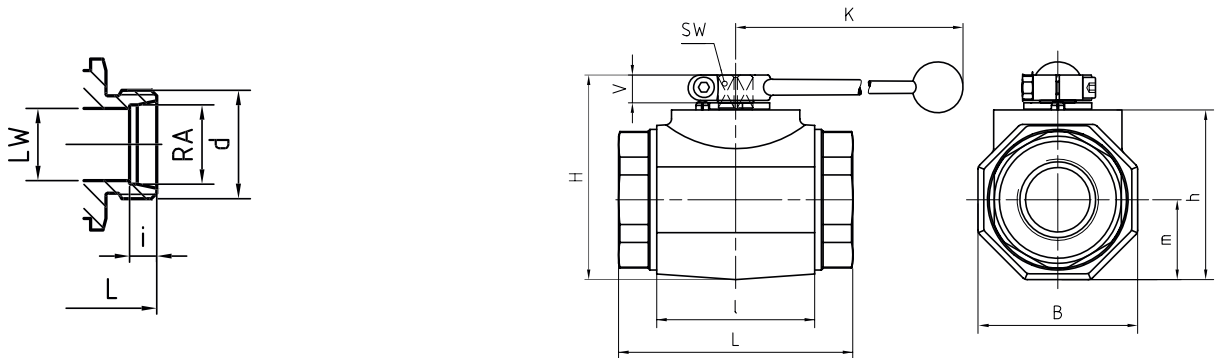

l	B	H	h	m	V	SW	K	LW	L	RA	i	d	Weight kg/1 piece	Order code	PN (bar)
80	81	107	86	40,5	16,5	17	320	32	111	35	10,5	M 45x2.0	3,58	9019-35	420
85	100	124	103	50	16,5	17	320	38	130	42	11	M 52x2.0	5,54	9019-42	420

Please note the pressure ratings of the tube connections!

9019-.. - 2-way Metric ball valve

DIN 2353 / ISO 8434-1 Heavy Series

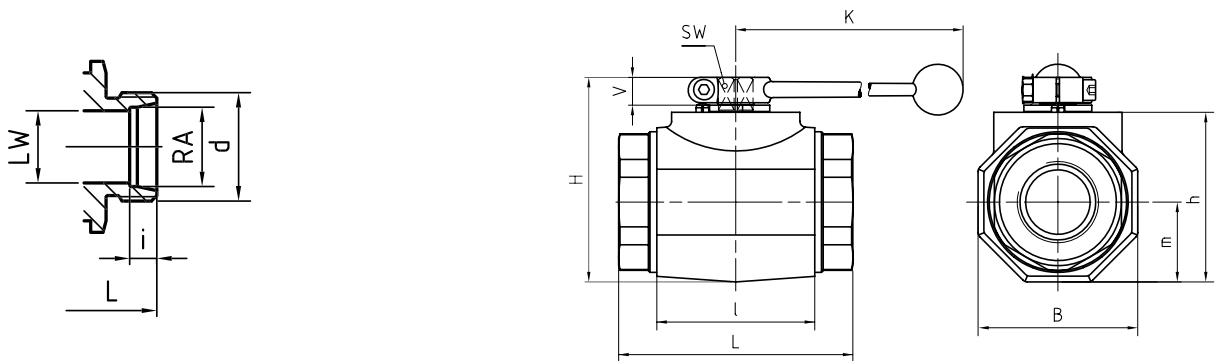

l	B	H	h	m	V	SW	K	LW	L	RA	i	d	Weight kg/1 piece	Order code	PN (bar)
80	81	107	86	40,5	16,5	17	320	32	148	38	16	M 52x2.0	3,77	9019-38	420

Please note the pressure ratings of the tube connections!

9028-.. - 2-way NPT ball valve (800 bar)

ANSI B1.20.1 NPT Female thread

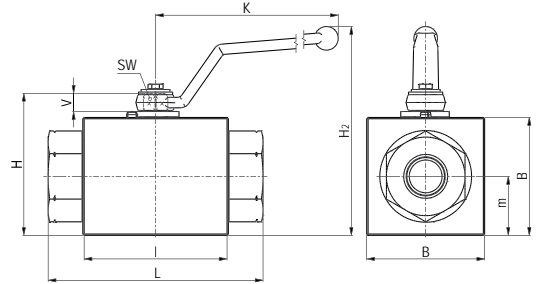
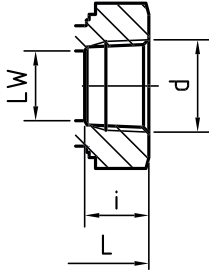

l	B	H	m	V	SW	K	H2	LW	L	i	d	Weight kg/1 piece	Order code	PN (bar)
76	50	64	25	11	9	115	101	6	130	13,7	1/4 NPT	1,92	9028-04	800
76	50	64	25	11	9	115	101	13	130	13,5	3/8 NPT	1,85	9028-06	800
76	50	64	25	11	9	115	101	13	130	17	1/2 NPT	1,79	9028-08	800
111	90	108	45	14	14	171	159	20	161	18,3	3/4 NPT	7,83	9028-12	800
111	90	108	45	14	14	171	159	25	164	21,6	1 NPT	7,68	9028-16	800

9029-.. - 2-way Metric ball valve (800 bar)

DIN 2353 / ISO 8434-1 Heavy Series

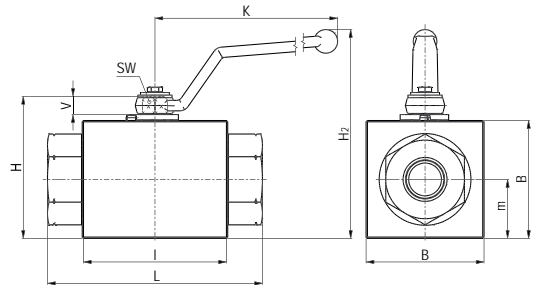
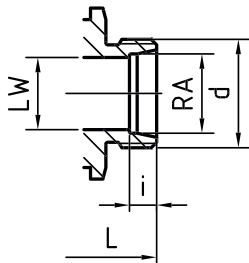

l	B	H	m	V	SW	K	H2	LW	RA	L	i	d	Weight kg/1 piece	Order code	PN (bar)
76	50	64	25	11	9	115	101	5	8	110	7	M 16x1.5	1,60	9029-08	800
76	50	64	25	11	9	115	101	6	10	114	7,5	M 18x1.5	1,60	9029-10	800
76	50	64	25	11	9	115	101	8	12	114	7,5	M 20x1.5	1,64	9029-12	800
76	50	64	25	11	9	115	101	13	14	114	8	M 22x1.5	1,56	9029-14	800
76	50	64	25	11	9	115	101	13	16	114	8,5	M 24x1.5	1,58	9029-16	800
76	50	64	25	11	9	115	101	13	20	118	10,5	M 30x2.0	1,63	9029-20	800
111	90	108	45	14	14	171	159	20	25	162	12	M 36x2.0	7,31	9029-25	800
111	90	108	45	14	14	171	159	25	30	166	13,5	M42 x2.0	7,40	9029-30	800

Please note the pressure ratings of the tube connections!

9001-.. - 3-way BSPP ball valve (L-bore)

DIN ISO 228 BSPP Female thread

 Pressure inlet only from center port (port 2)!

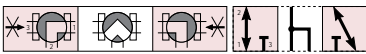
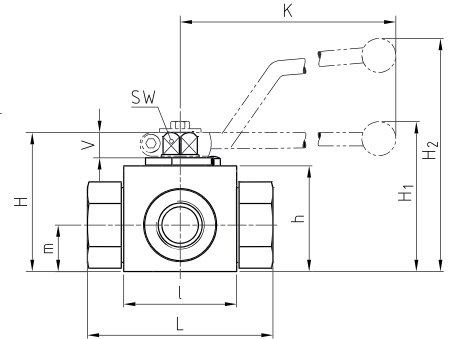
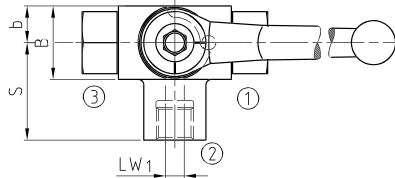
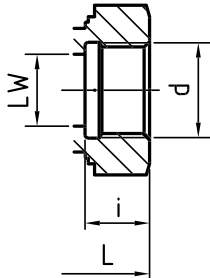

l	b	B	H	h	m	V	SW	K	H1	H2	LW	L	S	LW ₁	i	d	Weight kg/1 piece	Order code	PN (bar)
40	13	29	47	33	13,5	11	9	115	-	82	5	69	34,5	4	10	G 1/8	0,40	9001-02	500
40	13	29	47	33	13,5	11	9	115	-	82	6	69	34,5	6	14	G 1/4	0,46	9001-04	500
43	16	35	52	38	17,5	11	9	115	-	82	10	72	36	10	14	G 3/8	0,60	9001-06	500
48	17,5	38	54	40	19	11	9	115	-	86	13	83	41,5	13	16,6	G 1/2	0,70	9001-08	500
48	17,5	38	54	40	19	11	9	115	-	86	13	83	41,5	13	16	G 5/8	0,70	9001-10	500
62	24,5	52	75	57	24,5	14	14	200	79	-	20	95	47,5	20	18	G 3/4	1,80	9001-12	315
66	29	61	83	65	29,5	14	14	200	87	-	25	113	56,5	25	20	G 1	2,40	9001-16	315
66	29	61	83	65	29,5	14	14	200	87	-	25	120	57	25	22	G 1 1/4	2,64	9001-20	315
81	39	-	106	84.5	39	16,5	17	320	115	-	30	111	55	30	22	G 1 1/4	4,80	9001-20-DN32	350
104	53	-	127	106	53	16,5	17	320	136	-	38	130	65	38	24	G 1 1/2	8,90	9001-24	350
118	58	116	137	116	58	16,5	17	320	146	-	48	150	75	48	26	G 2	12,40	9001-32	350

Pressure inlet from all ports, add ADA behind Order code

9004-.. - 3-way BSPP ball valve (T-bore)

DIN ISO 228 BSPP Female thread

 Pressure inlet only from center port (port 2)!

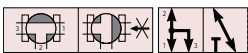
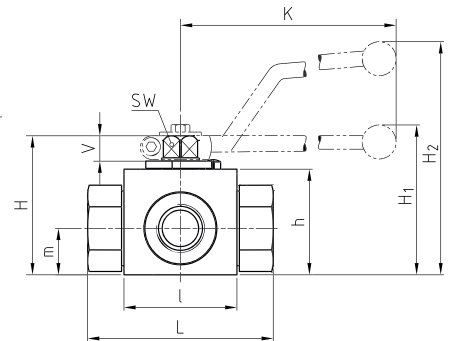
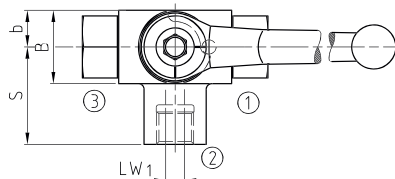
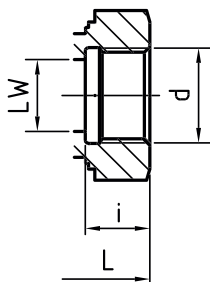

l	b	B	H	h	m	V	SW	K	H1	H2	LW	L	S	LW ₁	i	d	Weight kg/1 piece	Order code	PN (bar)
40	13	29	47	33	13,5	11	9	115	-	82	5	69	34,5	4	10	G 1/8	0,40	9004-02	500
40	13	29	47	33	13,5	11	9	115	-	82	6	69	34,5	6	14	G 1/4	0,46	9004-04	500
43	16	35	52	38	17,5	11	9	115	-	82	10	72	36	10	14	G 3/8	0,60	9004-06	500
48	17,5	38	54	40	19	11	9	115	-	86	13	83	41,5	13	16,6	G 1/2	0,70	9004-08	500
48	17,5	38	54	40	19	11	9	115	-	86	13	83	41,5	13	16	G 5/8	0,70	9004-10	500
62	24,5	52	75	57	24,5	14	14	200	79	-	20	95	47,5	20	18	G 3/4	1,80	9004-12	315
66	29	61	83	65	29,5	14	14	200	87	-	25	113	56,5	25	20	G 1	2,40	9004-16	315
66	29	61	83	65	29,5	14	14	200	87	-	25	120	57	25	22	G 1 1/4	2,64	9004-20	315
81	39	-	106	84.5	39	16,5	17	320	115	-	30	111	55	30	22	G 1 1/4	4,80	9004-20-DN32	350
104	53	-	127	106	53	16,5	17	320	136	-	38	130	65	38	24	G 1 1/2	8,90	9004-24	350
118	58	116	137	116	58	16,5	17	320	146	-	48	150	75	48	26	G 2	12,40	9004-32	350

Pressure inlet from all ports, add ADA behind Order code

9002-.. - 3-way Metric ball valve (L-bore)

DIN 2353 / ISO 8434-1 Light Series

 Pressure inlet only from center port (port 2)!

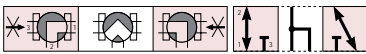
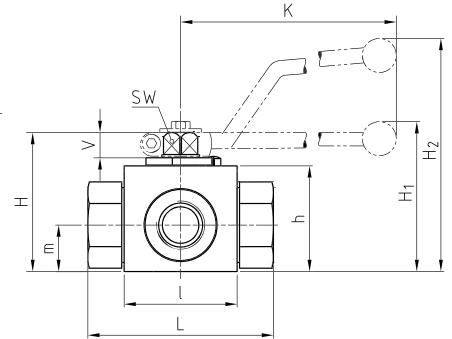
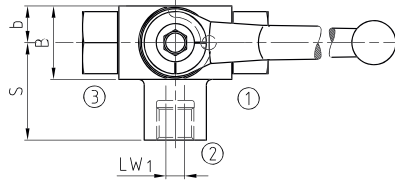
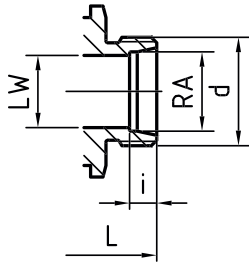

l	b	B	H	h	m	V	SW	K	H1	H2	LW	RA	L	S	LW ₁	i	d	Weight kg/1 piece	Order code	PN (bar)
40	13	29	47	33	13,5	11	9	115	-	82	5	6	67	33,5	4	7	M 12x1,5	0,30	9002-06	500
40	13	29	47	33	13,5	11	9	115	-	82	6	8	67	33,5	6	7	M 14x1,5	0,40	9002-08	500
40	13	29	47	33	13,5	11	9	115	-	82	8	10	74	34,5	8	7	M 16x1,5	0,40	9002-10	500
43	16	35	52	38	17,5	11	9	115	-	86	10	12	74	36,5	10	7	M 18x1,5	0,50	9002-12	500
48	17,5	38	54	40	19	11	9	115	-	89	13	15	82	41	13	7	M 22x1,5	0,65	9002-15	500
48	17,5	38	54	40	19	11	9	115	-	89	13	18	82	41,5	13	7,5	M 26x1,5	0,69	9002-18	500
62	24,5	52	75	57	24,5	14	14	200	79	-	20	22	101	48	20	7,5	M 30x2,0	1,50	9002-22	315
66	29	61	83	65	29,5	14	14	200	87	-	25	28	108	54	25	7,5	M 36x2,0	2,10	9002-28	315
66	29	61	83	65	29,5	14	14	200	87	-	25	35	112	56	25	10,5	M 45x2,0	2,50	9002-35	315

Please note the pressure ratings of the tube connections!
Pressure inlet from all ports, add ADA behind Order code

9005-.. - 3-way Metric ball valve (T-bore)

DIN 2353 / ISO 8434-1 Light Series

 Pressure inlet only from center port (port 2)!

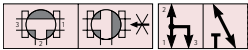
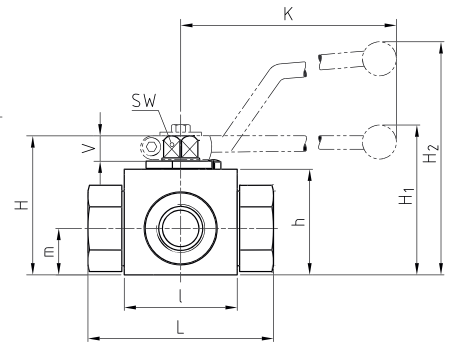
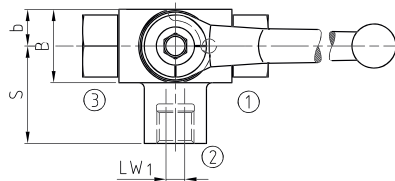
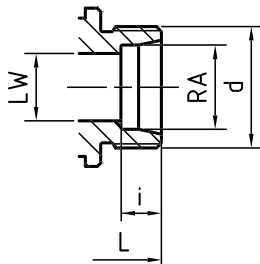

l	b	B	H	h	m	V	SW	K	H1	H2	LW	RA	L	S	LW ₁	i	d	Weight kg/1 piece	Order code	PN (bar)
40	13	29	47	33	13,5	11	9	115	-	82	5	6	67	33,5	4	7	M 12x1,5	0,30	9005-06	500
40	13	29	47	33	13,5	11	9	115	-	82	6	8	67	33,5	6	7	M 14x1,5	0,40	9005-08	500
40	13	29	47	33	13,5	11	9	115	-	82	8	10	74	34,5	8	7	M 16x1,5	0,40	9005-10	500
43	16	35	52	38	17,5	11	9	115	-	86	10	12	74	36,5	10	7	M 18x1,5	0,50	9005-12	500
48	17,5	38	54	40	19	11	9	115	-	89	13	15	82	41	13	7	M 22x1,5	0,65	9005-15	500
48	17,5	38	54	40	19	11	9	115	-	89	13	18	82	41,5	13	7,5	M 26x1,5	0,69	9005-18	500
62	24,5	52	75	57	24,5	14	14	200	79	-	20	22	101	48	20	7,5	M 30x2,0	1,50	9005-22	315
66	29	61	83	65	29,5	14	14	200	87	-	25	28	108	54	25	7,5	M 36x2,0	2,10	9005-28	315
66	29	61	83	65	29,5	14	14	200	87	-	25	35	112	56	25	10,5	M 45x2,0	2,50	9005-35	315

Please note the pressure ratings of the tube connections!
Pressure inlet from all ports, add ADA behind Order code

9003-.. - 3-way Metric ball valve (L-bore)

DIN 2353 / ISO 8434-1 Heavy Series

 Pressure inlet only from center port (port 2)!

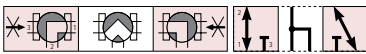
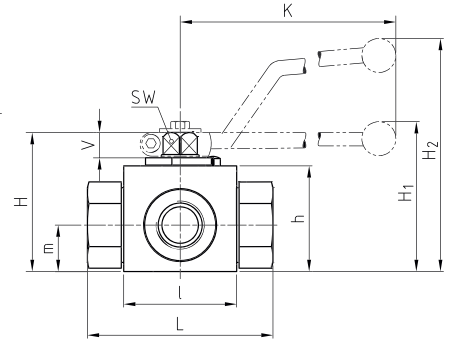
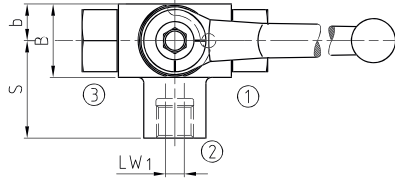
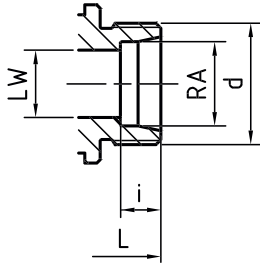

l	b	B	H	h	m	V	SW	K	H1	H2	LW	RA	L	S	LW1	i	d	Weight kg/1 piece	Order code	PN (bar)
40	13	29	47	33	13,5	11	9	115	-	82	5	8	73	34,5	4	7	M 16x1,5	0,42	9003-08	500
40	13	29	47	33	13,5	11	9	115	-	82	6	10	73	34,5	6	7,5	M 18x1,5	0,43	9003-10	500
40	13	29	47	33	13,5	11	9	115	-	82	8	12	76	34,5	8	7,5	M 20x1,5	0,44	9003-12	500
43	16	35	52	38	17,5	11	9	115	-	86	10	14	80	36,5	10	8	M 22x1,5	0,50	9003-14	500
48	17,5	38	54	40	19	11	9	115	-	89	13	16	86	43	13	8,5	M 24x1,5	0,65	9003-16	500
48	17,5	38	54	40	19	11	9	115	-	89	13	20	90	43	15	10,5	M 30x2,0	0,70	9003-20	500
62	24,5	52	75	57	24,5	14	14	200	79	-	20	25	109	48	20	12	M 36x2,0	1,70	9003-25	315
66	29	61	83	65	29,5	14	14	200	87	-	25	30	120	57,5	25	13,5	M 42x2,0	2,40	9003-30	315
66	29	61	83	65	29,5	14	14	200	87	-	25	38	124	57,5	25	16	M 52x2,0	2,80	9003-38	315

Please note the pressure ratings of the tube connections!
Pressure inlet from all ports, add ADA behind Order code

9006-.. - 3-way Metric ball valve (T-bore)

DIN 2353 / ISO 8434-1 Heavy Series

 Pressure inlet only from center port (port 2)!

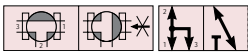
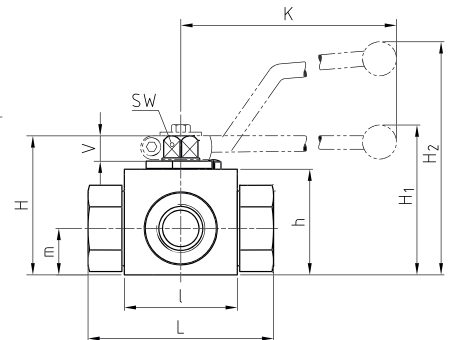
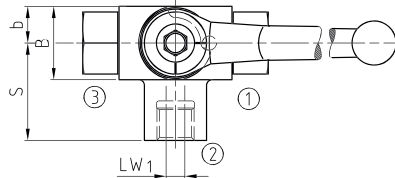
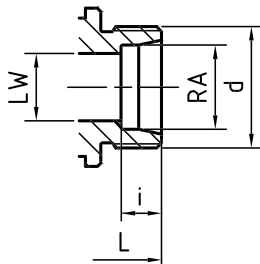

l	b	B	H	h	m	V	SW	K	H1	H2	LW	RA	L	S	LW1	i	d	Weight kg/1 piece	Order code	PN (bar)
40	13	29	47	33	13,5	11	9	115	-	82	5	8	73	34,5	4	7	M 16x1,5	0,42	9006-08	500
40	13	29	47	33	13,5	11	9	115	-	82	6	10	73	34,5	6	7,5	M 18x1,5	0,43	9006-10	500
40	13	29	47	33	13,5	11	9	115	-	82	8	12	76	34,5	8	7,5	M 20x1,5	0,44	9006-12	500
43	16	35	52	38	17,5	11	9	115	-	86	10	14	80	36,5	10	8	M 22x1,5	0,50	9006-14	500
48	17,5	38	54	40	19	11	9	115	-	89	13	16	86	43	13	8,5	M 24x1,5	0,65	9006-16	500
48	17,5	38	54	40	19	11	9	115	-	89	13	20	90	43	15	10,5	M 30x2,0	0,70	9006-20	500
62	24,5	52	75	57	24,5	14	14	200	79	-	20	25	109	48	20	12	M 36x2,0	1,70	9006-25	315
66	29	61	83	65	29,5	14	14	200	87	-	25	30	120	57,5	25	13,5	M 42x2,0	2,40	9006-30	315
66	29	61	83	65	29,5	14	14	200	87	-	25	38	124	57,5	25	16	M 52x2,0	2,80	9006-38	315

Please note the pressure ratings of the tube connections!
Pressure inlet from all ports, add ADA behind Order code

9030-.. - BSPP 3-way ball valve (L-bore)

DIN ISO 228 BSPP Female thread

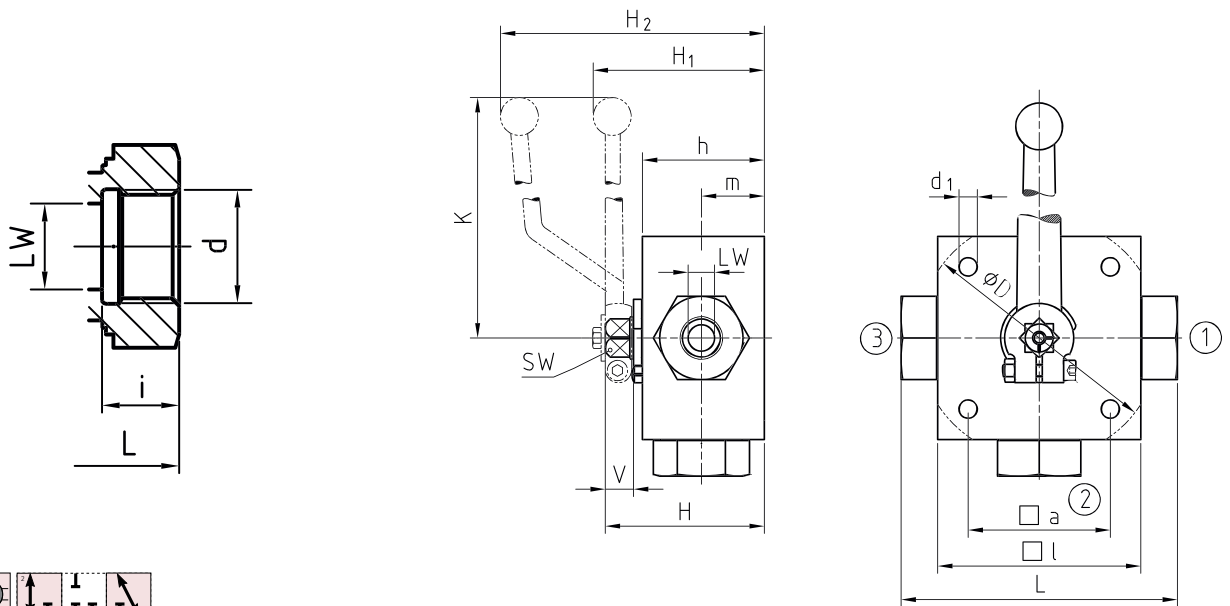

LW	D	a	l	d ₁	H	h	m	K	V	SW	H ₁	H ₂	L	i	d	Weight kg/1 piece	Order code	PN (bar)
5	-	55	70	6,5	58	40	22	160	14	12	-	101	100	10	G 1/8	1,60	9030-02	500
5	-	55	70	6,5	58	40	22	160	14	12	-	101	100	14	G 1/4	1,60	9030-04	500
8	-	65	80	6,5	68	50	27	200	14	14	72	-	115	14	G 3/8	2,70	9030-06	500
13	-	80	100	9	78	60	31	200	14	14	82	-	136	16,3	G 1/2	4,90	9030-08	400
13	-	80	100	9	78	60	31	200	14	14	82	-	139	18	G 5/8	4,90	9030-10	400
18	138	85	113	8,5	88	67	36,5	320	16,5	17	96	-	154	18	G 3/4	6,70	9030-12	315
23	138	85	119	8,5	103	82	47,5	320	16,5	17	112	-	172	20	G 1	8,30	9030-16	315
23	138	85	119	8,5	103	82	47,5	320	16,5	17	112	-	180	22	G 1 1/4	8,50	9030-20	315
23	138	85	119	8,5	103	82	47,5	320	16,5	17	112	-	180	24	G 1 1/2	8,50	9030-24	250

9033-.. - BSPP 3-way ball valve (T-bore)

DIN ISO 228 BSPP Female thread

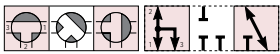
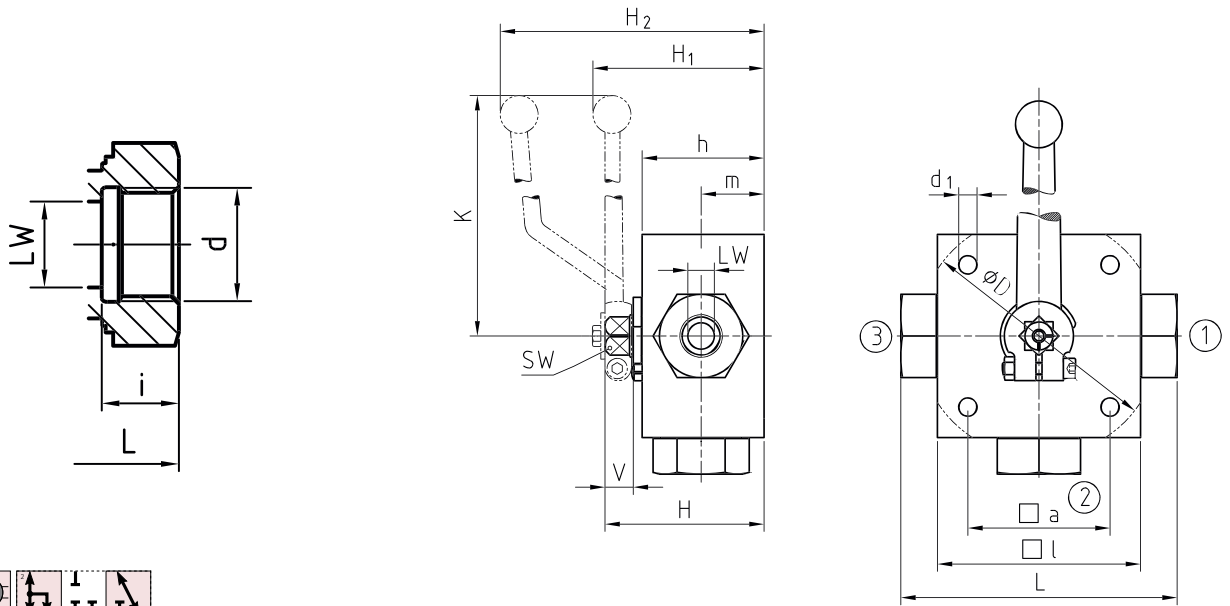

LW	D	a	l	d ₁	H	h	m	K	V	SW	H ₁	H ₂	L	i	d	Weight kg/1 piece	Order code	PN (bar)
5	-	55	70	6,5	58	40	22	160	14	12	-	101	100	10	G 1/8	1,60	9033-02	500
5	-	55	70	6,5	58	40	22	160	14	12	-	101	100	14	G 1/4	1,60	9033-04	500
8	-	65	80	6,5	68	50	27	200	14	14	72	-	115	14	G 3/8	2,70	9033-06	500
13	-	80	100	9	78	60	31	200	14	14	82	-	136	16,3	G 1/2	4,90	9033-08	400
13	-	80	100	9	78	60	31	200	14	14	82	-	139	18	G 5/8	4,90	9033-10	400
18	138	85	113	8,5	88	67	36,5	320	16,5	17	96	-	154	18	G 3/4	6,70	9033-12	315
23	138	85	119	8,5	103	82	47,5	320	16,5	17	112	-	172	20	G 1	8,30	9033-16	315
23	138	85	119	8,5	103	82	47,5	320	16,5	17	112	-	180	22	G 1 1/4	8,50	9033-20	315
23	138	85	119	8,5	103	82	47,5	320	16,5	17	112	-	180	24	G 1 1/2	8,50	9033-24	250

9031-.. - Metric 3-way ball valve (L-bore)

DIN 2353 / ISO 8434-1 Light Series

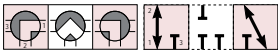
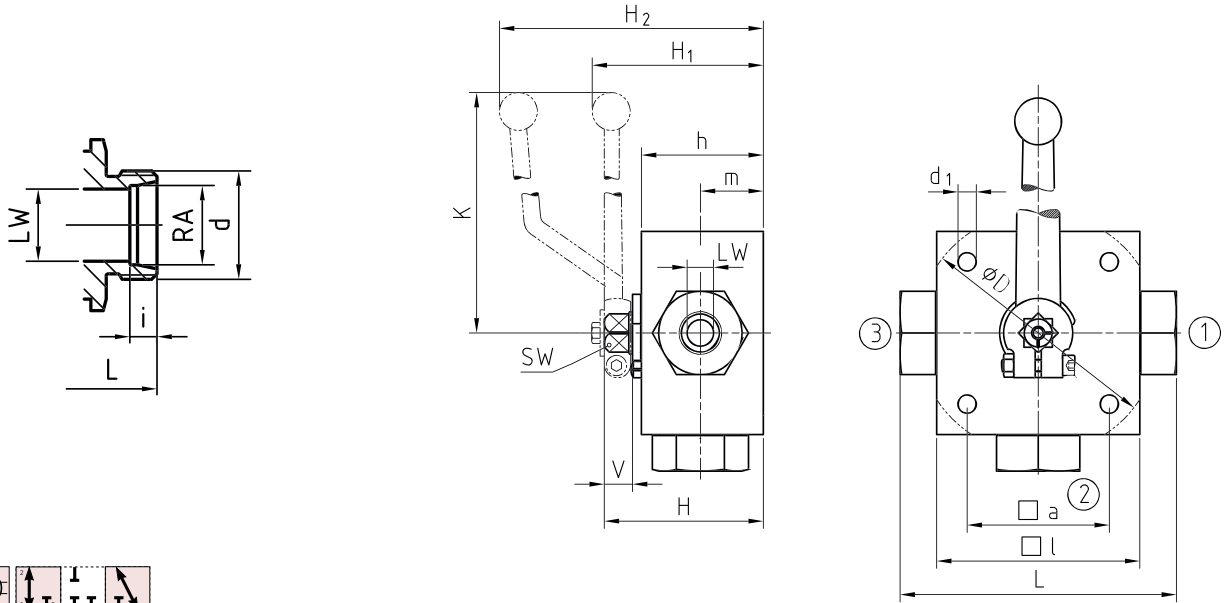

LW	D	a	l	d ₁	H	h	m	K	V	SW	H ₁	H ₂	L	RA	i	d	Weight kg/1 piece	Order code	PN (bar)
5	-	55	70	6,5	58	40	22	160	14	12	-	101	105	6	7	M 12x1,5	1,60	9031-06	500
5	-	55	70	6,5	58	40	22	160	14	12	-	101	105	8	7	M 14x1,5	1,80	9031-08	500
8	-	65	80	6,5	68	50	27	200	14	14	72	-	114	10	7	M 16x1,5	2,60	9031-10	500
8	-	65	80	6,5	68	50	27	200	14	14	72	-	114	12	7	M 18x1,5	2,60	9031-12	500
13	-	80	100	9	78	60	31	200	14	14	82	-	137	15	7	M 22x1,5	4,70	9031-15	400
13	-	80	100	9	78	60	31	200	14	14	82	-	137	18	7,5	M 26x1,5	4,70	9031-18	400
18	138	85	113	8,5	88	67	36,5	320	16,5	17	96	-	152	22	7,5	M 30x2,0	6,60	9031-22	315
23	138	85	119	8,5	103	82	47,5	320	16,5	17	112	-	166	28	7,5	M 36x2,0	8,00	9031-28	315
23	138	85	119	8,5	103	82	47,5	320	16,5	17	112	-	170	35	10,5	M 45x2,0	8,12	9031-35	315

Please note the pressure ratings of the tube connections

9034-.. - Metric 3-way ball valve (T-bore)

DIN 2353 / ISO 8434-1 Light Series

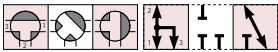
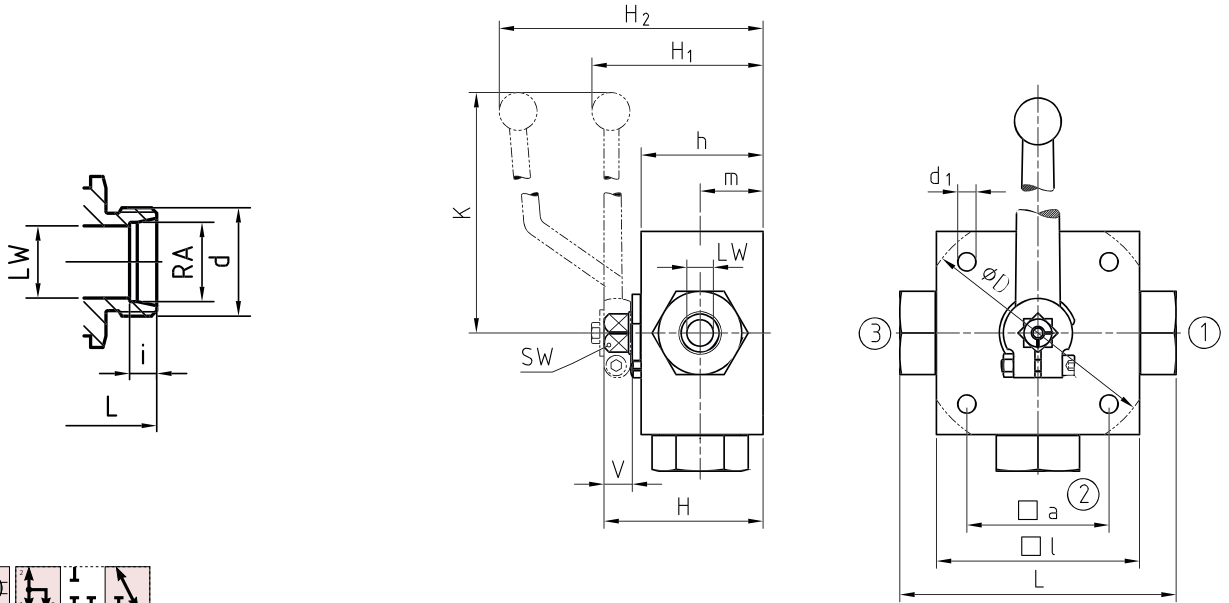

LW	D	a	l	d ₁	H	h	m	K	V	SW	H ₁	H ₂	L	RA	i	d	Weight kg/1 piece	Order code	PN (bar)
5	-	55	70	6,5	58	40	22	160	14	12	-	101	105	6	7	M 12x1,5	1,60	9034-06	500
5	-	55	70	6,5	58	40	22	160	14	12	-	101	105	8	7	M 14x1,5	1,80	9034-08	500
8	-	65	80	6,5	68	50	27	200	14	14	72	-	114	10	7	M 16x1,5	2,60	9034-10	500
8	-	65	80	6,5	68	50	27	200	14	14	72	-	114	12	7	M 18x1,5	2,60	9034-12	500
13	-	80	100	9	78	60	31	200	14	14	82	-	137	15	7	M 22x1,5	4,70	9034-15	400
13	-	80	100	9	78	60	31	200	14	14	82	-	137	18	7,5	M 26x1,5	4,70	9034-18	400
18	138	85	113	8,5	88	67	36,5	320	16,5	17	96	-	152	22	7,5	M 30x2,0	6,60	9034-22	315
23	138	85	119	8,5	103	82	47,5	320	16,5	17	112	-	166	28	7,5	M 36x2,0	8,00	9034-28	315
23	138	85	119	8,5	103	82	47,5	320	16,5	17	112	-	170	35	10,5	M 45x2,0	8,12	9034-35	315

Please note the pressure ratings of the tube connections!

9032-.. - Metric 3-way ball valve (L-bore)

DIN 2353 / ISO 8434-1 Heavy Series

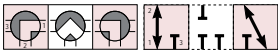
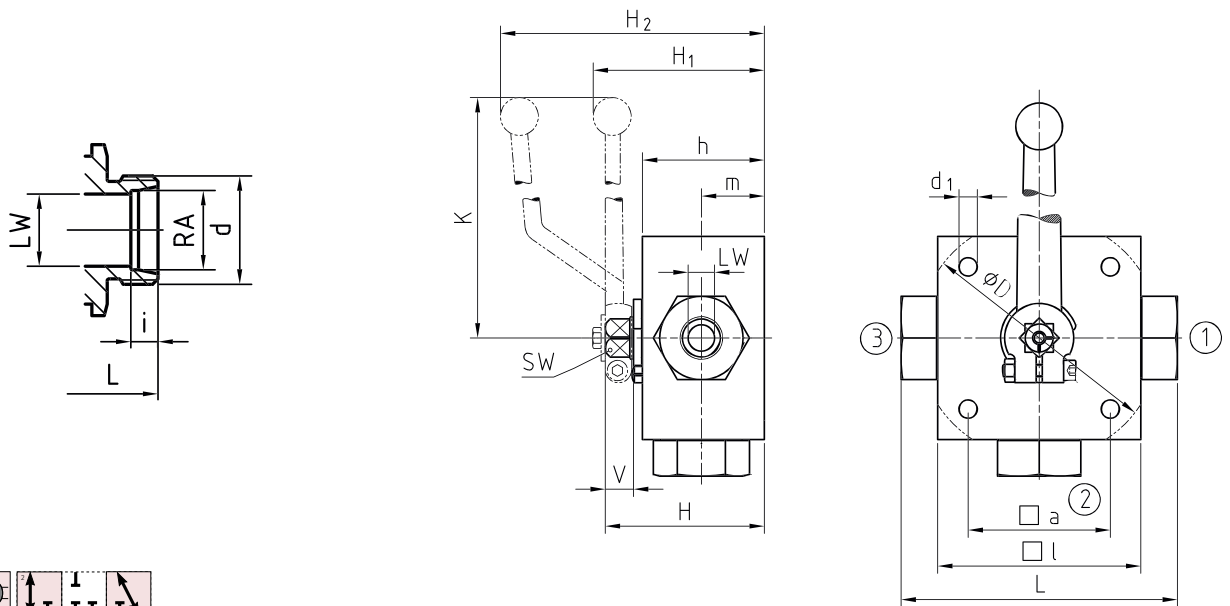

LW	D	a	l	d ₁	H	h	m	K	V	SW	H ₁	H ₂	L	RA	i	d	Weight kg/1 piece	Order code	PN (bar)
5	-	55	70	6,5	58	40	22	160	14	12	-	101	105	8	7	M 16x1,5	1,60	9032-08	500
5	-	55	70	6,5	58	40	22	160	14	12	-	101	105	10	7,5	M 18x1,5	1,60	9032-10	500
8	-	65	80	6,5	68	50	27	200	14	14	72	-	116	12	7,5	M 20x1,5	2,60	9032-12	500
10	-	65	80	6,5	68	50	27	200	14	14	72	-	120	14	8	M 22x1,5	2,60	9032-14	500
13	-	80	100	9	78	60	31	200	14	14	82	-	141	16	8,5	M 24x1,5	4,70	9032-16	400
13	-	80	100	9	78	60	31	200	14	14	82	-	145	20	10,5	M 30x2,0	4,70	9032-20	400
20	138	85	113	8,5	88	67	36,5	320	16,5	17	96	-	160	25	12	M 36x2,0	6,60	9032-25	315
25	138	85	119	8,5	103	82	47,5	320	16,5	17	112	-	176	30	13,5	M 42x2,0	8,00	9032-30	315
25	138	85	119	8,5	103	82	47,5	320	16,5	17	112	-	180	38	16	M 52x2,0	8,30	9032-38	315

Please note the pressure ratings of the tube connections!

9035-.. - Metric 3-way ball valve (T-bore)

DIN 2353 / ISO 8434-1 Heavy Series

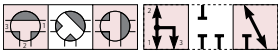
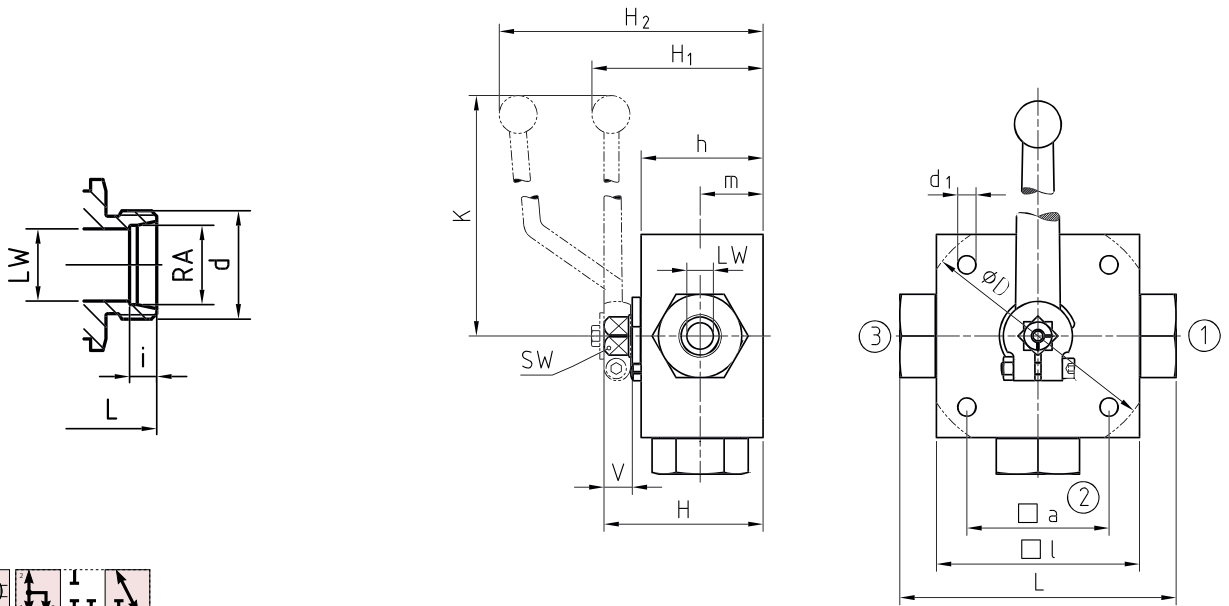

LW	D	a	l	d ₁	H	h	m	K	V	SW	H ₁	H ₂	L	RA	i	d	Weight kg/1 piece	Order code	PN (bar)
5	-	55	70	6,5	58	40	22	160	14	12	-	101	105	8	7	M 16x1,5	1,60	9035-08	500
5	-	55	70	6,5	58	40	22	160	14	12	-	101	105	10	7,5	M 18x1,5	1,60	9035-10	500
8	-	65	80	6,5	68	50	27	200	14	14	72	-	116	12	7,5	M 20x1,5	2,60	9035-12	500
10	-	65	80	6,5	68	50	27	200	14	14	72	-	120	14	8	M 22x1,5	2,60	9035-14	500
13	-	80	100	9	78	60	31	200	14	14	82	-	141	16	8,5	M 24x1,5	4,70	9035-16	400
13	-	80	100	9	78	60	31	200	14	14	82	-	145	20	10,5	M 30x2,0	4,70	9035-20	400
20	138	85	113	8,5	88	67	36,5	320	16,5	17	96	-	160	25	12	M 36x2,0	6,60	9035-25	315
25	138	85	119	8,5	103	82	47,5	320	16,5	17	112	-	176	30	13,5	M 42x2,0	8,00	9035-30	315
25	138	85	119	8,5	103	82	47,5	320	16,5	17	112	-	180	38	16	M 52x2,0	8,30	9035-38	315

Please note the pressure ratings of the tube connections!

9043-.. - BSPP 4-way ball valve (T-bore)

DIN ISO 228 BSPP Female thread

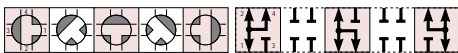
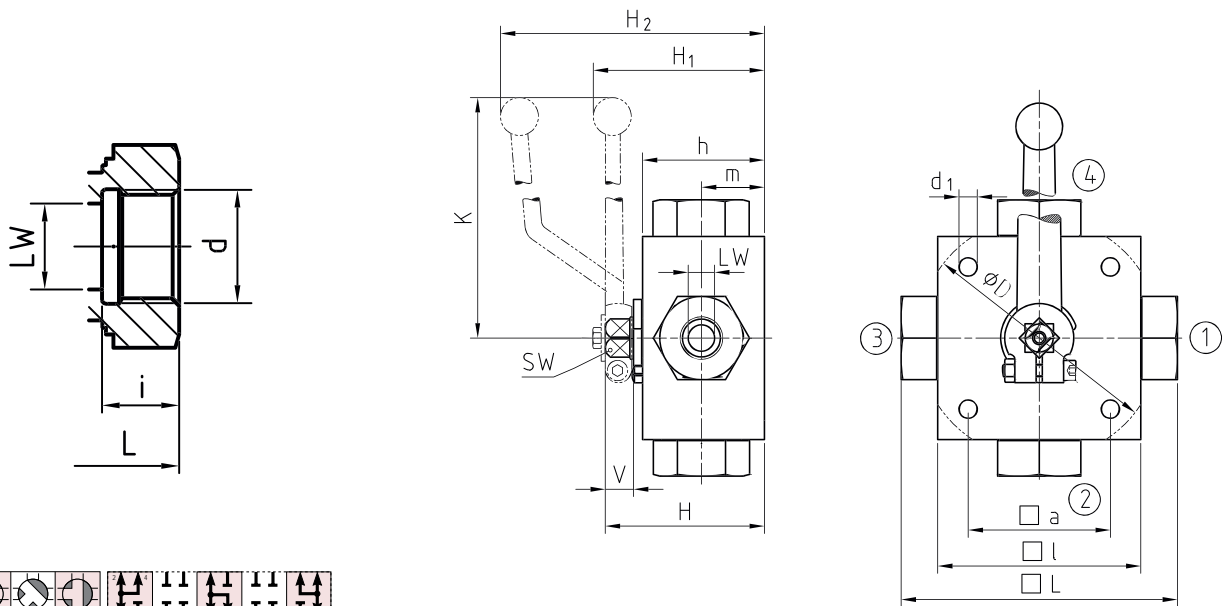

LW	D	a	l	d ₁	H	h	m	K	V	SW	H ₁	H ₂	L	i	d	Weight kg/1 piece	Order code	PN (bar)
5	-	55	70	6,5	58	40	22	160	14	12	-	101	100	10	G 1/8	1,60	9043-02	500
5	-	55	70	6,5	58	40	22	160	14	12	-	101	100	14	G 1/4	1,60	9043-04	500
8	-	65	80	6,5	68	50	27	200	14	14	72	-	115	14	G 3/8	2,80	9043-06	500
13	-	80	100	9	78	60	31	200	14	14	82	-	136	16,3	G 1/2	4,90	9043-08	400
13	-	80	100	9	78	60	31	200	14	14	82	-	139	18	G 5/8	4,90	9043-10	400
18	138	85	113	8,5	88	67	36,5	320	16,5	17	96	-	154	18	G 3/4	6,80	9043-12	315
23	138	85	119	8,5	103	82	47,5	320	16,5	17	112	-	172	20	G 1	8,50	9043-16	315
23	138	85	119	8,5	103	82	47,5	320	16,5	17	112	-	180	22	G 1 1/4	8,80	9043-20	315
23	138	85	119	8,5	103	82	47,5	320	16,2	17	112	-	180	24	G 1 1/2	8,80	9043-24	250

9044-.. - Metric 4-way ball valve (T-bore)

DIN 2353 / ISO 8434-1 Light Series

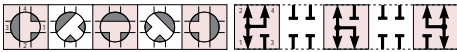
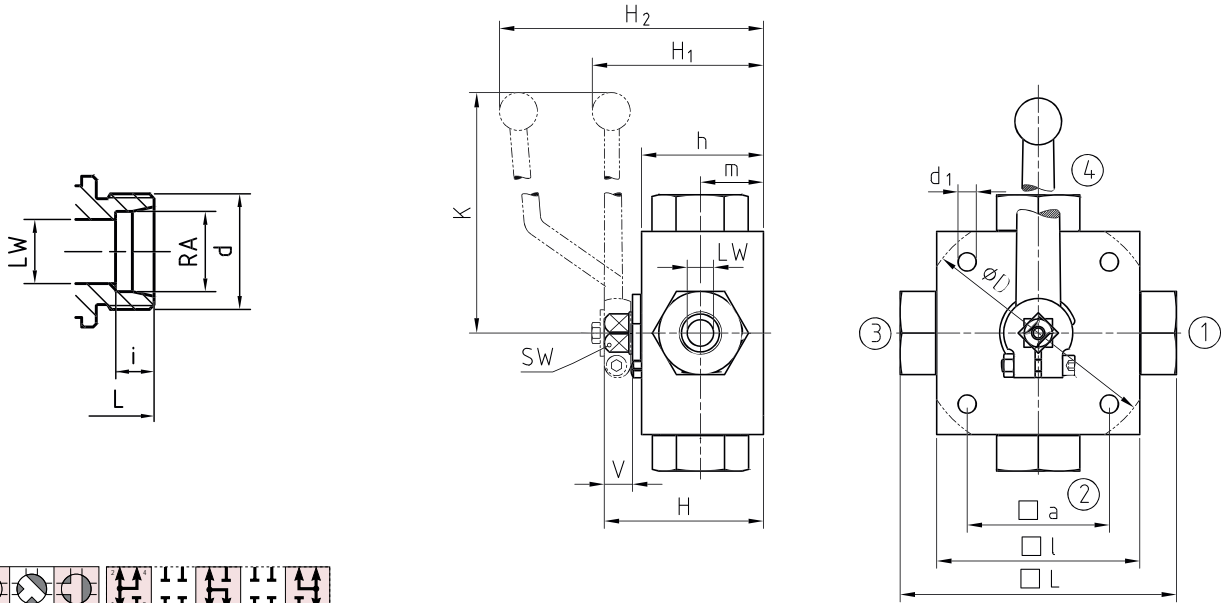

LW	D	a	l	d ₁	H	h	m	K	V	SW	H ₁	H ₂	L	RA	i	d	Weight kg/1 piece	Order code	PN (bar)
5	-	55	70	6,5	58	40	22	160	14	12	-	101	105	6	7	M 12x1,5	1,60	9044-06	500
5	-	55	70	6,5	58	40	22	160	14	12	-	101	105	8	7	M 14x1,5	1,80	9044-08	500
8	-	65	80	6,5	68	50	27	200	14	14	72	-	114	10	7	M 16x1,5	2,60	9044-10	500
8	-	65	80	6,5	68	50	27	200	14	14	72	-	114	12	7	M 18x1,5	2,60	9044-12	500
13	-	80	100	9	78	60	31	200	14	14	82	-	137	15	7	M 22x1,5	4,70	9044-15	400
13	-	80	100	9	78	60	31	200	14	14	82	-	137	18	7,5	M 26x1,5	4,70	9044-18	400
18	138	85	113	8,5	88	67	36,5	320	16,5	17	96	-	152	22	7,5	M 30x2,0	6,60	9044-22	315
23	138	85	119	8,5	103	82	47,5	320	16,5	17	112	-	166	28	7,5	M 36x2,0	8,00	9044-28	315
23	138	85	119	8,5	103	82	47,5	320	16,5	17	112	-	170	35	10,5	M 45x2,0	8,12	9044-35	315

Please note the pressure ratings of the tube connections!

9045-.. - Metric 4-way ball valve (T-bore)

DIN 2353 / ISO 8434-1 Heavy Series

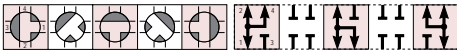
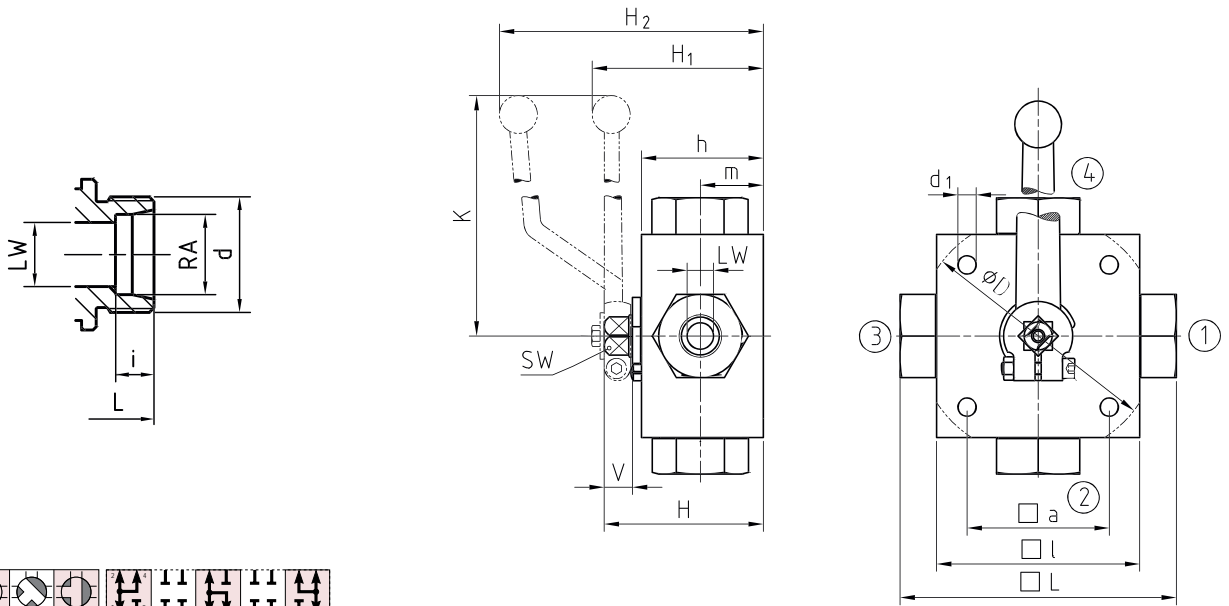

LW	D	a	l	d ₁	H	h	m	K	V	SW	H ₁	H ₂	L	RA	i	d	Weight kg/1 piece	Order code	PN (bar)
5	-	55	70	6,5	58	40	22	160	14	12	-	101	105	8	7	M 16x1,5	1,60	9045-08	500
5	-	55	70	6,5	58	40	22	160	14	12	-	101	105	10	7,5	M 18x1,5	1,60	9045-10	500
8	-	65	80	6,5	68	50	27	200	14	14	72	-	116	12	7,5	M 20x1,5	2,60	9045-12	500
8	-	65	80	6,5	68	50	27	200	14	14	72	-	120	14	8	M 22x1,5	2,60	9045-14	500
13	-	80	100	9	78	60	31	200	14	14	82	-	141	16	8,5	M 24x1,5	4,70	9045-16	400
13	-	80	100	9	78	60	31	200	14	14	82	-	145	20	10,5	M 30x2,0	4,70	9045-20	400
18	138	85	113	8,5	88	67	36,5	320	16,5	17	96	-	160	25	12	M 36x2,0	6,60	9045-25	315
23	138	85	119	8,5	103	82	47,5	320	16,5	17	112	-	176	30	13,5	M 42x2,0	8,20	9045-30	315
23	138	85	119	8,5	103	82	47,5	320	16,5	17	112	-	180	38	16	M 52x2,0	8,30	9045-38	315

Please note the pressure ratings of the tube connections!

9046-.. - BSPP 4-way ball valve (X-bore)

DIN ISO 228 BSPP Female thread

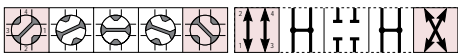
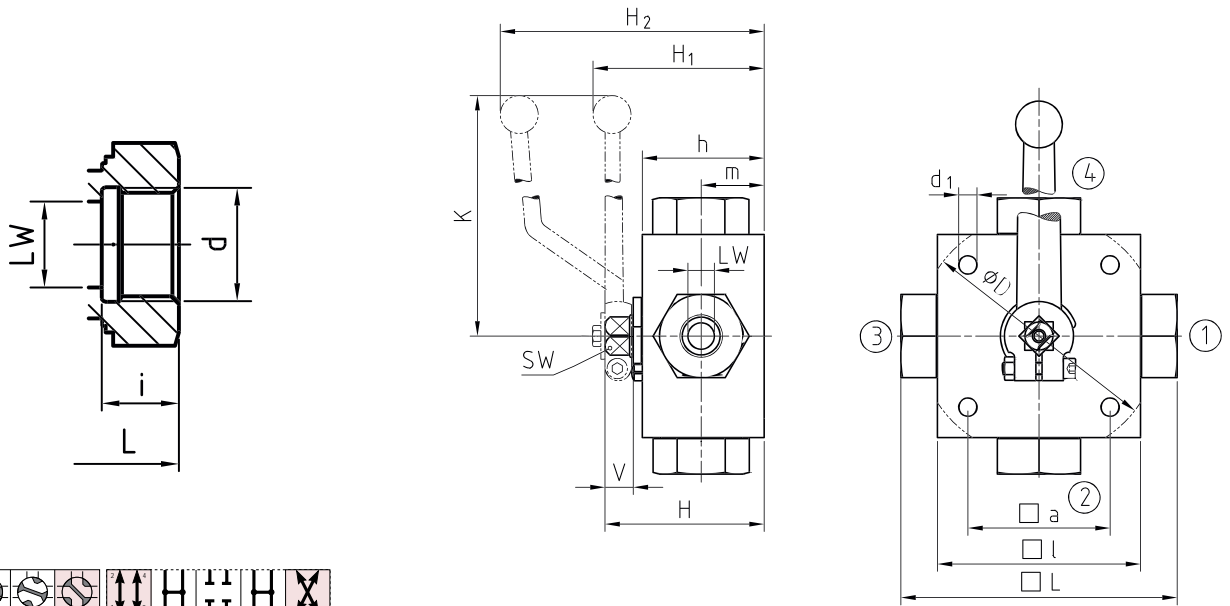

LW	D	a	l	d ₁	H	h	m	K	V	SW	H ₁	H ₂	L	i	d	Weight kg/1 piece	Order code	PN (bar)
4	-	55	70	6,5	58	40	22	160	14	12	-	101	100	10	G 1/8	1,60	9046-02	500
4	-	55	70	6,5	58	40	22	160	14	12	-	101	100	14	G 1/4	1,60	9046-04	500
7	-	65	80	6,5	68	50	27	200	14	14	72	-	115	14	G 3/8	2,80	9046-06	500
10	-	80	100	9	78	60	31	200	14	14	82	-	136	16,3	G 1/2	4,90	9046-08	400
10	-	80	100	9	78	60	31	200	14	14	82	-	139	18	G 5/8	4,90	9046-10	400
14	138	85	113	8,5	88	67	36,5	320	16,5	17	96	-	154	18	G 3/4	6,80	9046-12	315
17	138	85	119	8,5	103	82	47,5	320	16,5	17	112	-	172	20	G 1	8,50	9046-16	315
17	138	85	119	8,5	103	82	47,5	320	16,5	17	112	-	180	22	G 1 1/4	8,80	9046-20	315
17	138	85	119	8,5	103	82	47,5	320	16,2	17	112	-	180	24	G 1 1/2	8,80	9046-24	250

9047-.. - Metric 4-way ball valve (X-bore)

DIN 2353 / ISO 8434-1 Light Series

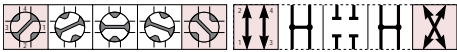
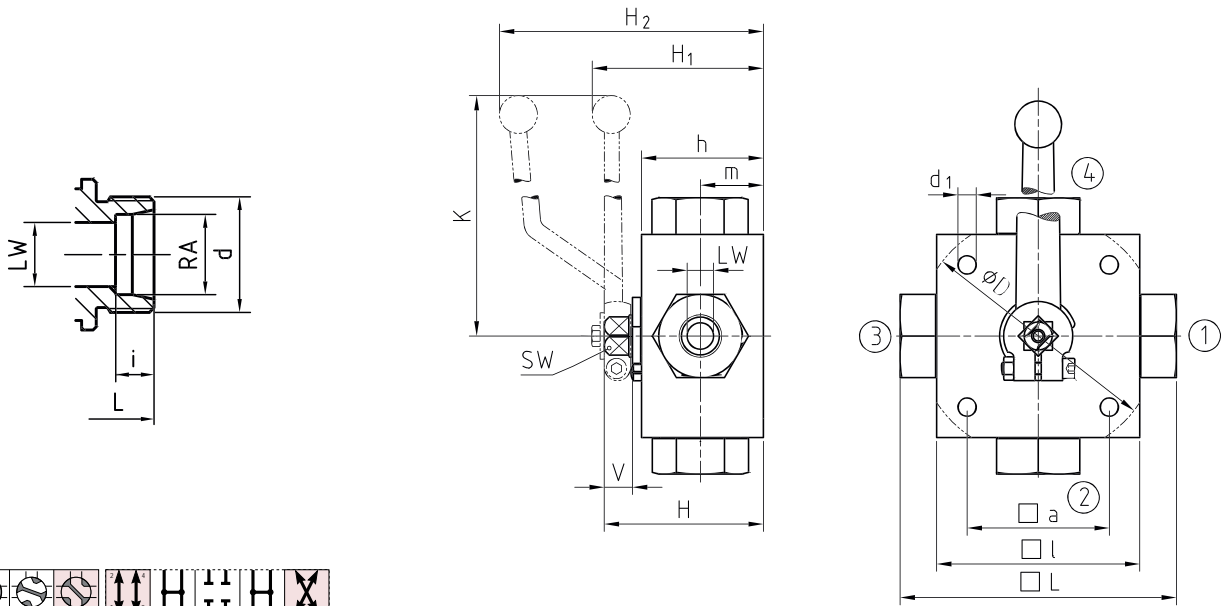

LW	D	a	l	d ₁	H	h	m	K	V	SW	H ₁	H ₂	L	RA	i	d	Weight kg/1 piece	Order code	PN (bar)
4	-	55	70	6,5	58	40	22	160	14	12	-	101	105	6	7	M 12x1,5	1,60	9047-06	500
4	-	55	70	6,5	58	40	22	160	14	12	-	101	105	8	7	M 14x1,5	1,80	9047-08	500
7	-	65	80	6,5	68	50	27	200	14	14	72	-	114	10	7	M 16x1,5	2,60	9047-10	500
7	-	65	80	6,5	68	50	27	200	14	14	72	-	114	12	7	M 18x1,5	2,60	9047-12	500
10	-	80	100	9	78	60	31	200	14	14	82	-	137	15	7	M 22x1,5	4,70	9047-15	400
10	-	80	100	9	78	60	31	200	14	14	82	-	137	18	7,5	M 26x1,5	4,70	9047-18	400
14	138	85	113	8,5	88	67	36,5	320	16,5	17	96	-	152	22	7,5	M 30x2,0	6,60	9047-22	315
17	138	85	119	8,5	103	82	47,5	320	16,5	17	112	-	166	28	7,5	M 36x2,0	8,00	9047-28	315
17	138	85	119	8,5	103	82	47,5	320	16,5	17	112	-	170	35	10,5	M 45x2,0	8,12	9047-35	315

Please note the pressure ratings of the tube connections!

9048-.. - Metric 4-way ball valve (X-bore)

DIN 2353 / ISO 8434-1 Heavy Series

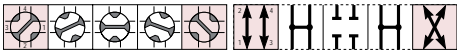
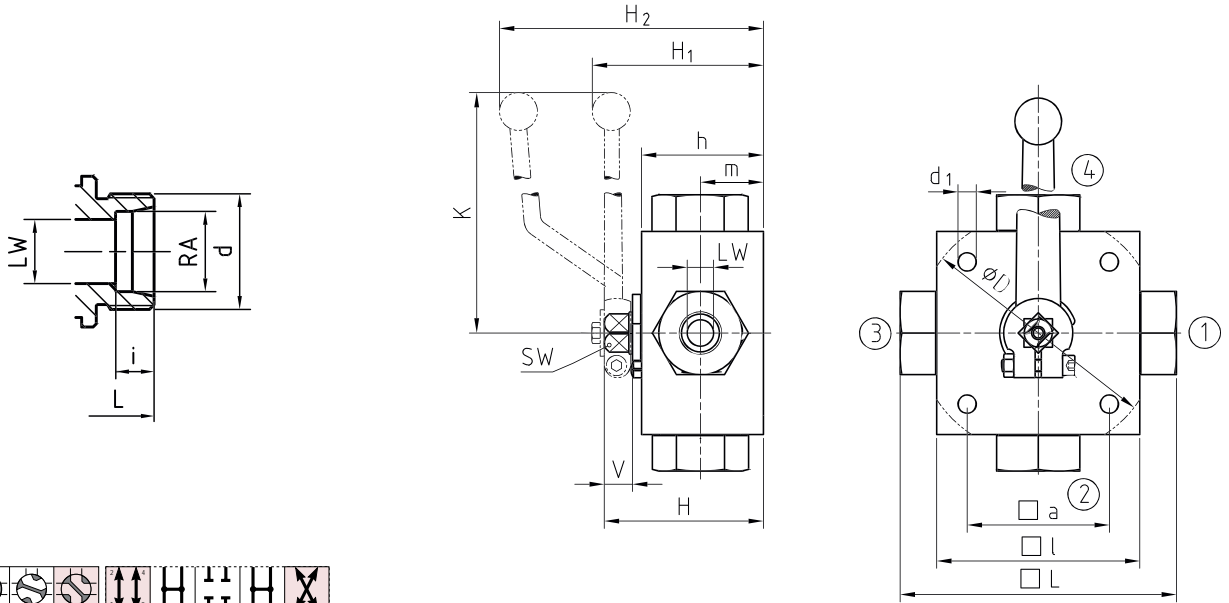

LW	D	a	l	d ₁	H	h	m	K	V	SW	H ₁	H ₂	L	RA	i	d	Weight kg/1 piece	Order code	PN (bar)
4	-	55	70	6,5	58	40	22	160	14	12	-	101	105	8	7	M 16x1,5	1,60	9048-08	500
4	-	55	70	6,5	58	40	22	160	14	12	-	101	105	10	7,5	M 18x1,5	1,60	9048-10	500
7	-	65	80	6,5	68	50	27	200	14	14	72	-	116	12	7,5	M 20x1,5	2,60	9048-12	500
7	-	65	80	6,5	68	50	27	200	14	14	72	-	120	14	8	M 22x1,5	2,60	9048-14	500
10	-	80	100	9	78	60	31	200	14	14	82	-	141	16	8,5	M 24x1,5	4,70	9048-16	400
10	-	80	100	9	78	60	31	200	14	14	82	-	145	20	10,5	M 30x2,0	4,70	9048-20	400
14	138	85	113	8,5	88	67	36,5	320	16,5	17	96	-	160	25	12	M 36x2,0	6,60	9048-25	315
17	138	85	119	8,5	103	82	47,5	320	16,5	17	112	-	176	30	13,5	M 42x2,0	8,20	9048-30	315
17	138	85	119	8,5	103	82	47,5	320	16,5	17	112	-	180	38	16	M 52x2,0	8,30	9048-38	315

Please note the pressure ratings of the tube connections!

9020-.. - Flange ball valve with SAE connection

ISO 6162-1 and -2 (double flange pattern)

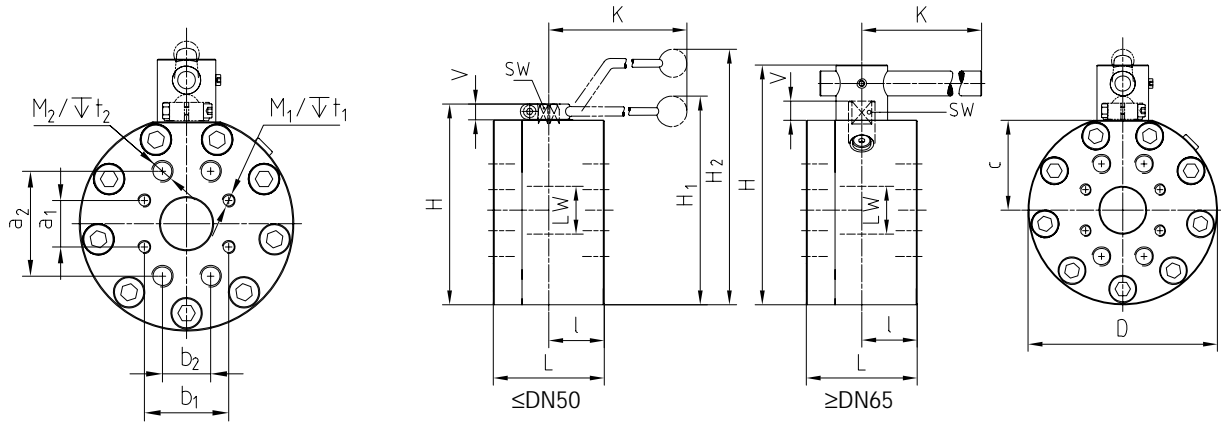

LW	L	I	D	H	c	V	K	SW	H ₁	H ₂	a ₁	b ₁	M ₁	T ₁	a ₂	b ₂	M ₂	T ₂	Weight kg/1 piece	Order code	PN (bar)
15	75	35	88	88	31	13	160	12	-	132	17,5	38,1	M8	18	40,5	18,2	M8	18	2.96	9020-08	350/420
20	80	35	98	100	36,5	14	200	14	103	-	22,2	47,6	M10	18	50,8	23,8	M10	18	4.20	9020-12	350/420
25	88	38	118	113	39,5	14	200	14	116	-	27,8	57,2	M12	20	52,4	26,2	M10	20	6.00	9020-16	350/420
32	100	50	145	158	68	17	320	17	167	-	30,2	58,7	M10	20	66,7	31,8	M12	22	11.70	9020-20	280/420
38	110	55	165	178	78	17	320	17	187	-	35,7	69,9	M12	21	79,4	36,5	M16	27	17.10	9020-24	210/420
48	116	58	198	210	94	17	320	17	219	-	42,9	77,8	M12	20	96,8	44,5	M20	28	24.60	9020-32	210/420
63	170	75	218	275	100	20	600	16	-	-	58,7	123,8	M24	41	88,9	50,8	M12	19	44.40	9020-40	175/420
76	170	79	258	315	114,5	26	600	19	-	-	71,4	152,4	M30	17	106,4	61,9	M16	24	60.40	9020-48	160/420

Please note the pressure ratings of the tube connections!

9021-.. - Flange ball valve with SAE connection

ISO 6162-1 and -2 (double flange pattern)

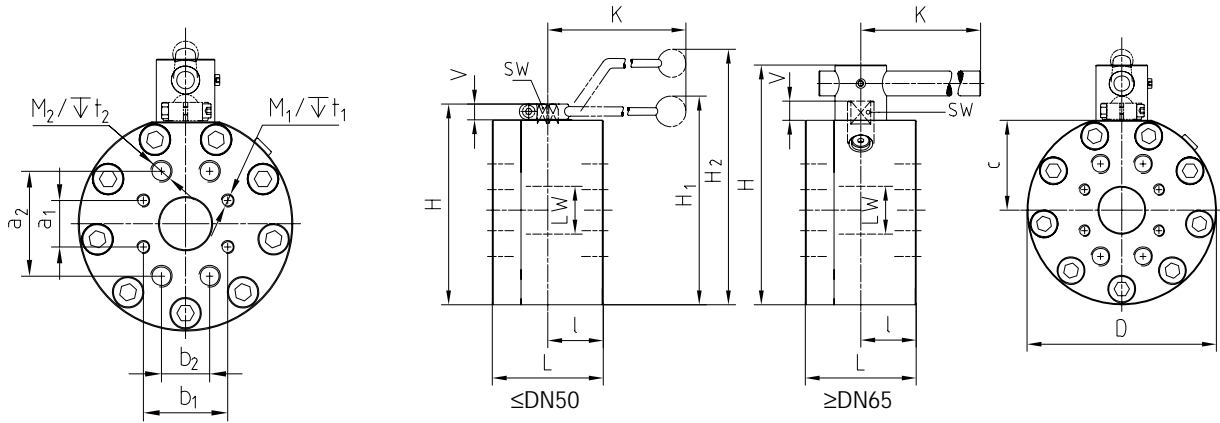

LW	L	I	D	H	c	V	K	SW	H ₁	H ₂	a ₁	b ₁	M ₁	T ₁	a ₂	b ₂	M ₂	T ₂	Weight kg/1 piece	Order code	PN (bar)
15	75	35	88	88	31	13	160	12	-	132	17,5	38,1	M8	18	40,5	18,2	M8	18	2.96	9021-08	350/420
20	80	35	98	100	36,5	14	200	14	103	-	22,2	47,6	M10	18	50,8	23,8	M10	18	4.20	9021-12	350/420
25	88	38	118	113	39,5	14	200	14	116	-	27,8	57,2	M12	20	52,4	26,2	M10	20	6.00	9021-16	350/420
32	100	50	145	158	68	17	320	17	167	-	30,2	58,7	M10	20	66,7	31,8	M12	22	11.70	9021-20	280/420
38	110	55	165	178	78	17	320	17	187	-	35,7	69,9	M12	21	79,4	36,5	M16	27	17.10	9021-24	210/420
48	116	58	198	210	94	17	320	17	219	-	42,9	77,8	M12	20	96,8	44,5	M20	28	24.60	9021-32	210/420
63	170	75	218	275	100	20	600	16	-	-	58,7	123,8	M24	41	88,9	50,8	M12	19	44.40	9021-40	175/420
76	170	79	258	315	114,5	26	600	19	-	-	71,4	152,4	M30	17	106,4	61,9	M16	24	60.40	9021-48	160/420

Please note the pressure ratings of the tube connections!

9022-.. - Ball valve with SAE split flange adapter

ISO 6162-1 - 3000 PSI

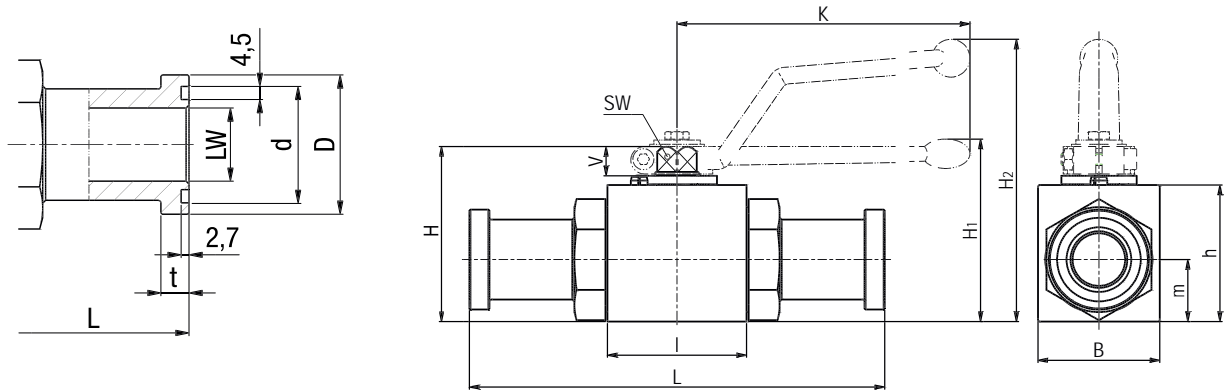

LW	l	B	H	h	m	V	SW	K	H ₁	H ₂	L	d	D	t	Weight kg/1 piece	Order code	PN (bar)
13	48	35	54	40	19	11	9	115	-	89	151	25,5	30,2	6,8	0,85	9022-08	350
19	62	49	75	57	24,5	14	14	200	79	-	162	31,9	38,1	6,8	1,87	9022-12	350
25	66	58	83	65	29,5	14	14	200	87	-	178	39,8	44,4	8,1	2,70	9022-16	315
30	80	81	107	86	40,5	16,5	17	320	-	-	191	44,6	50,8	8,1	4,22	9022-20	280
38	85	100	124	103	50	16,5	17	320	-	-	231	54,1	60,3	8,1	6,54	9022-24	210
48	100	118	138	117	59	16,5	17	320	-	-	232	63,6	71,4	9,6	9,29	9022-32	210

Please note the pressure ratings of the tube connections!

9023-.. - Ball valve with SAE split flange adapter

ISO 6162-2 - 6000 PSI

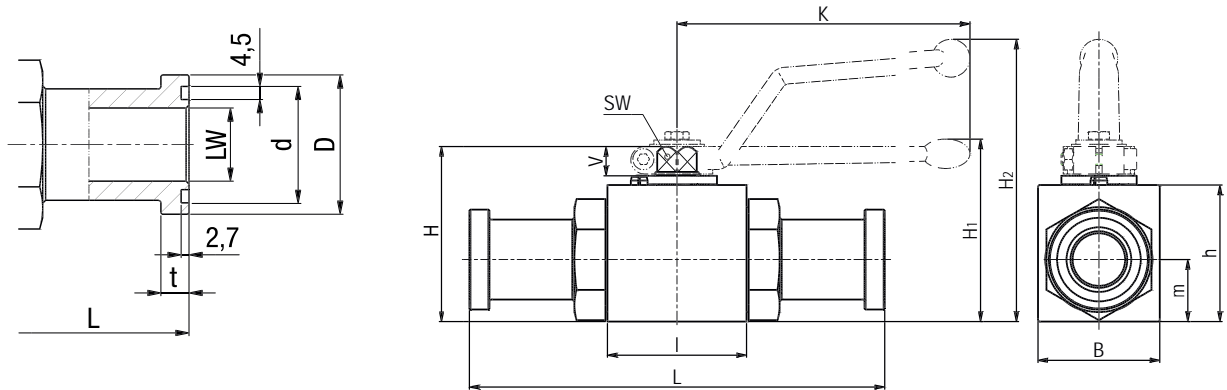

LW	l	B	H	h	m	V	SW	K	H ₁	H ₂	L	d	D	t	Weight kg/1 piece	Order code	PN (bar)
13	48	35	54	40	19	11	9	115	-	89	151	25,5	31,8	7,9	0,90	9023-08	420
19	62	49	75	57	24,5	14	14	200	79	-	174	31,9	41,3	8,9	1,99	9023-12	420
25	74	70	88	70	34,5	14	14	200	92	-	206	39,8	47,7	9,6	3,66	9023-16	420
30	80	81	107	86	40,5	16,5	17	320	-	-	223	44,6	54	10,4	4,72	9023-20	420
38	85	100	124	103	50	16,5	17	320	-	-	281	54,1	63,5	12,7	7,49	9023-24	420
48	100	118	138	117	59	16,5	17	320	-	-	316	63,6	79,4	12,7	11,39	9023-32	420

Please note the pressure ratings of the tube connections!

9024-.. - Ball valve with SAE adapter

ISO 6162-1 - 3000 PSI

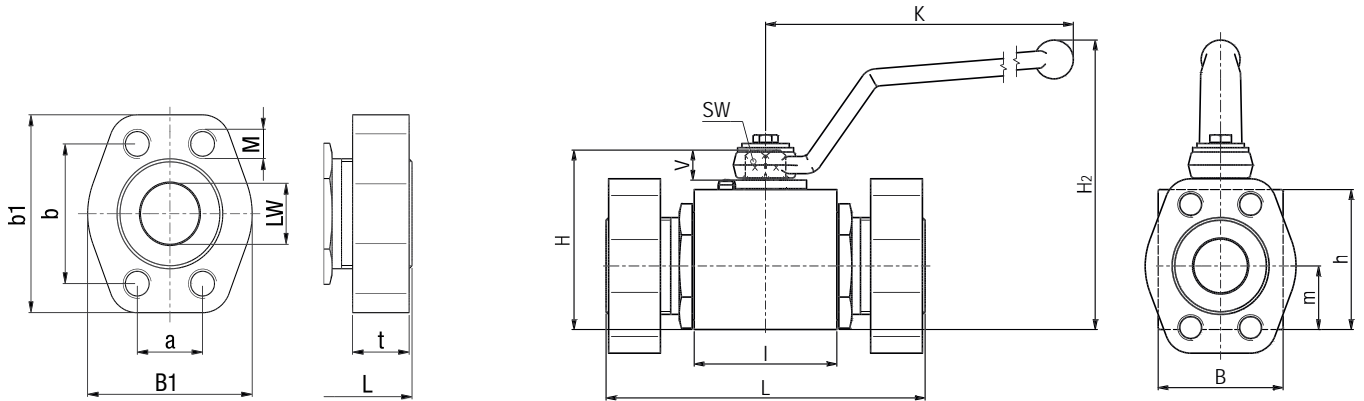

LW	l	B	H	h	m	V	SW	K	H ₂	L	B ₁	b ₁	t	a	b	M	Weight kg/1 piece	Order code	PN (bar)
13	48	35	54	40	19	11	9	115	89	120	48	56	13	17,5	38,1	M8	1,50	9024-08	350
20	62	49	75	57	24,5	14	14	171	127	136	50	65	14	22,2	47,6	M10	3,00	9024-12	350
25	66	58	83	65	29,5	14	14	171	135	148	60	70	16	26,2	52,4	M10	4,50	9024-16	315
32	80	81	107	103	40,5	16,5	17	306	197	172	68	79	16	30,2	58,7	M10	7,52	9024-20	280
38	85	100	124	103	50	16,5	17	306	211	177	78	93	16	35,7	69,9	M12	11,09	9024-24	210
48	100	118	138	117	59	16,5	17	306	211	196	90	102	16	42,9	77,8	M12	19,29	9024-32	210

Please note the pressure ratings of the tube connections!

9025-.. - Ball valve with SAE adapter

ISO 6162-2 - 6000 PSI

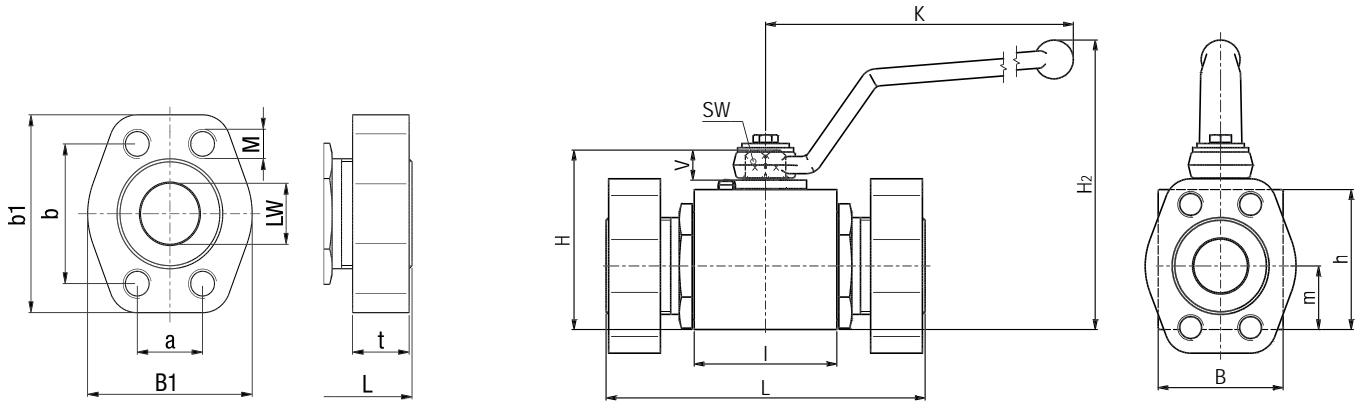

LW	l	B	H	h	m	V	SW	K	H ₂	L	B ₁	b ₁	t	a	b	M	Weight kg/1 piece	Order code	PN (bar)
13	48	35	54	40	19	11	9	115	89	120	48	56	16	18,2	40,5	M8	1,50	9025-08	420
20	62	49	75	57	24,5	14	14	171	127	136	60	71	19	23,8	50,8	M10	2,75	9025-12	420
25	66	58	83	65	29,5	14	14	171	135	156	70	81	24	27,8	57,2	M12	4,50	9025-16	420
32	80	81	107	103	40,5	16,5	17	306	197	172	78	95	27	31,8	66,7	M14	7,52	9025-20	420
38	85	100	124	103	50	16,5	17	306	211	177	94	112	30	36,5	79,4	M16	11,09	9025-24	420
48	100	118	138	117	59	16,5	17	306	211	196	114	134	35	44,5	96,8	M20	19,29	9025-32	420

Please note the pressure ratings of the tube connections!

9026-.. - Ball valve with SAE adapter / split flange adapter

ISO 6162-1 - 3000 PSI

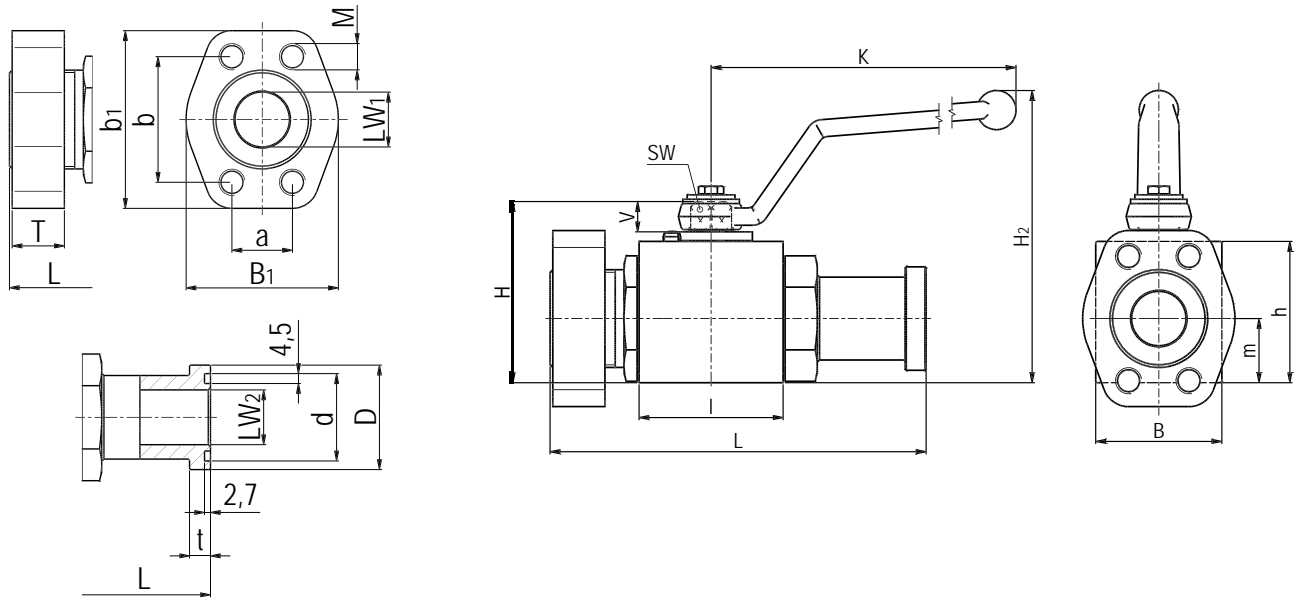

LW ₁	LW ₂	l	B	H	h	m	V	SW	K	H ₂	L	B ₁	b ₁	T	a	b	M	d	D	t	Weight kg/1 piece	Order code	PN (bar)
13	13	48	35	54	40	19	11	9	115	89	136	48	56	13	17,5	38,1	M8	25,5	30,2	6,8	1,18	9026-08	350
20	19	62	49	75	57	24,5	14	14	171	127	149	50	65	14	22,2	47,6	M10	31,9	38,1	6,8	2,15	9026-12	350
25	25	66	58	83	65	29,5	14	14	171	135	163	60	70	16	26,2	52,4	M10	39,8	44,4	8,1	3,60	9026-16	315
32	30	80	81	107	86	40,5	16,5	17	306	180	181	68	79	16	30,2	58,7	M10	44,6	50,8	8,1	5,87	9026-20	280
38	38	85	100	124	103	50	16,5	17	306	197	204	78	93	16	35,7	69,9	M12	54,1	60,3	8,1	8,82	9026-24	210
48	48	100	118	138	117	59	16,5	17	306	211	214	90	102	16	42,9	77,8	M12	63,6	71,4	9,6	14,30	9026-32	210

Please note the pressure ratings of the tube connections!

9027-.. - Ball valve with SAE adapter / split flange adapter

ISO 6162-2 - 6000 PSI

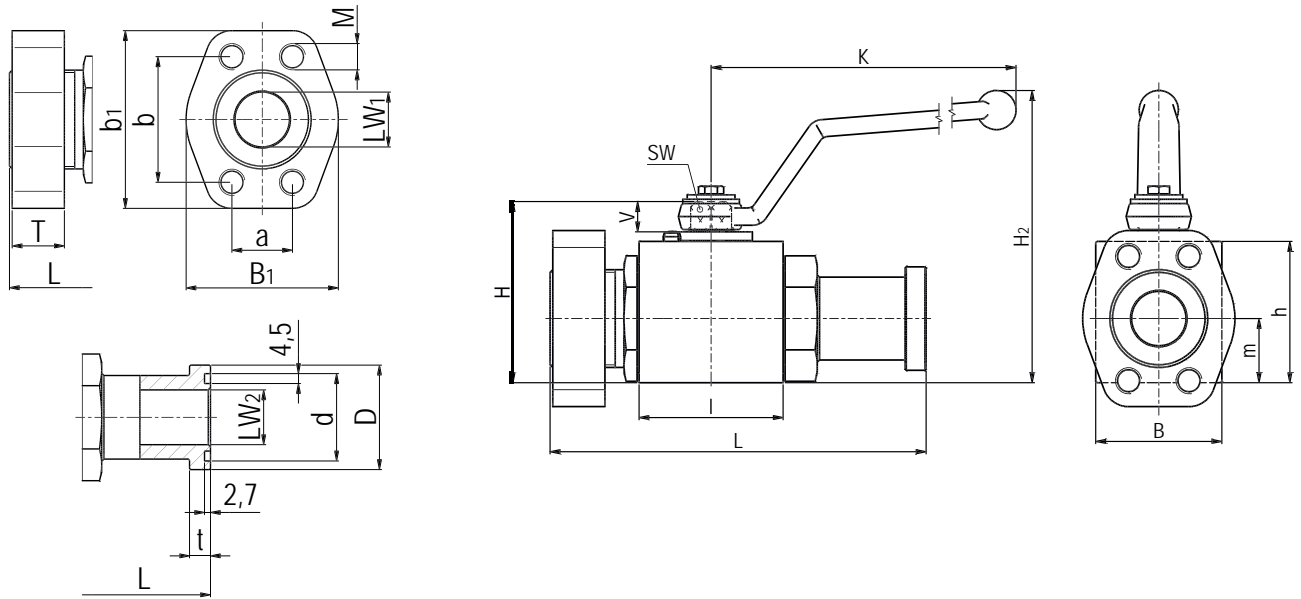

LW ₁	LW ₂	l	B	H	h	m	V	SW	K	H ₂	L	B ₁	b ₁	T	a	b	M	d	D	t	Weight kg/1 piece	Order code	PN (bar)
13	13	48	35	54	40	19	11	9	115	89	136	48	56	16	18,2	40,5	M8	25,5	31,8	7,9	1,20	9027-08	420
20	19	62	49	75	57	24,5	14	14	171	127	155	60	71	19	23,8	50,8	M10	31,9	41,3	8,9	2,26	9027-12	420
25	25	66	58	83	65	29,5	14	14	171	135	181	70	81	24	27,8	57,2	M12	39,8	47,6	9,6	3,75	9027-16	420
32	30	80	81	107	86	40,5	16,5	17	306	180	198	78	95	27	31,8	66,7	M12	44,6	54	10,4	6,12	9027-20	420
38	38	85	100	124	103	50	16,5	17	306	197	229	94	112	30	36,5	79,4	M16	54,1	53,5	12,7	9,29	9027-24	420
48	48	100	118	138	117	59	16,5	17	306	211	256	114	134	35	44,5	96,8	M20	63,6	79,4	12,7	15,34	9027-32	420

Please note the pressure ratings of the tube connections!

9114-.. - Bent levers

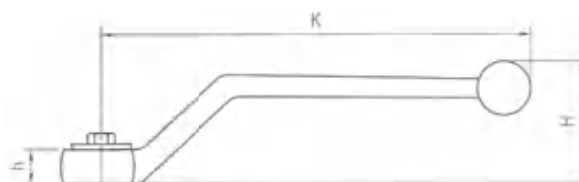

SW	K	h	H	material	Weight kg/1 piece	Order code
9	115	8,7	45	zinc	0,09	9114-19
9	115	9	47	steel	0,10	9114-01
9	115	8,7	45	stainless	0,10	9114-19RVS
14	171	12	64	steel	0,25	9117-21
14	160	12	48	stainless	0,20	9117-21RVS
17	306	16	89	steel	0,70	9117-22
17	227,5	15	90	stainless	0,40	9117-22RVS

9114-.. - Bent levers

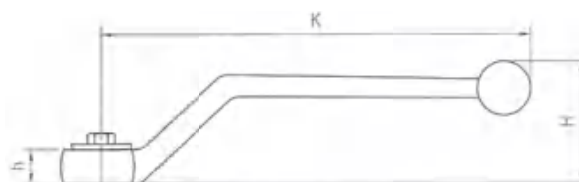

SW	K	h	H	material	Weight kg/1 piece	Order code
12	160	12	55	aluminium	0,07	9114-02

9114-.. - Straight levers

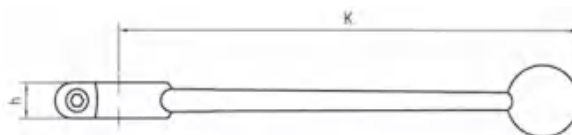

SW	K	h	material	Weight kg/1 piece	Order code
9	155	10	zinc	0,09	9114-09
14	200	13	zinc	0,26	9114-30

9114-.. - Straight levers

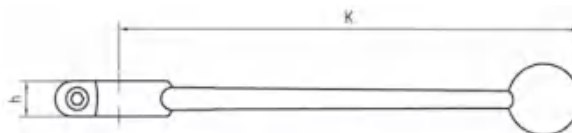

SW	K	h	material	Weight kg/1 piece	Order code
9	150	11	aluminium	0,09	9114-10
14	200	12	aluminium	0,11	9114-12
14	320	16	aluminium	0,26	9114-13

UC-.... - Inline Check Valves

Valve crack pressures: 0.35 and 4.5 bar

Construction:

Steel UNI 5105

Ball and spring:

Chrome finished steel

Retainer:

Nylon

Flow rates:

From 20 l/min to 150 l/min.

Max. working pressure:

350 bar.

Valve crack pressures:

0.35 and 4.5 bar

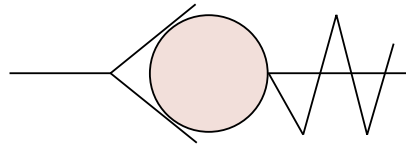

Circuit Symbol

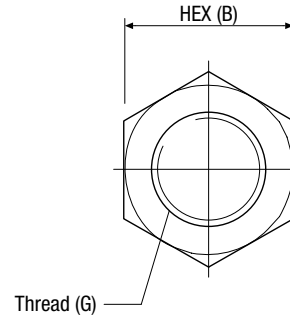
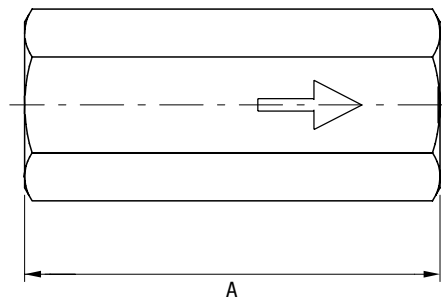

Flow l/min	Cracking pressure (bar)	Thread G	A (mm)	B (mm)	Weight kg/1 piece	Order code
20	0.35	1/4	54	19	0.09	UC-2301
30	0.35	3/8	66	24	0.17	UC-2302
50	0.35	1/2	77	30	0.32	UC-2303
100	0.35	3/4	88	36	0.48	UC-2304
150	0.35	1	108	46	0.99	UC-2305
20	4.50	1/4	54	19	0.09	UC-2311
30	4.50	3/8	65	24	0.17	UC-2312
50	4.50	1/2	77	30	0.32	UC-2313
100	4.50	3/4	88	36	0.48	UC-2314
150	4.50	1	108	46	0.99	UC-2315

Pressure Drop Flow Curves

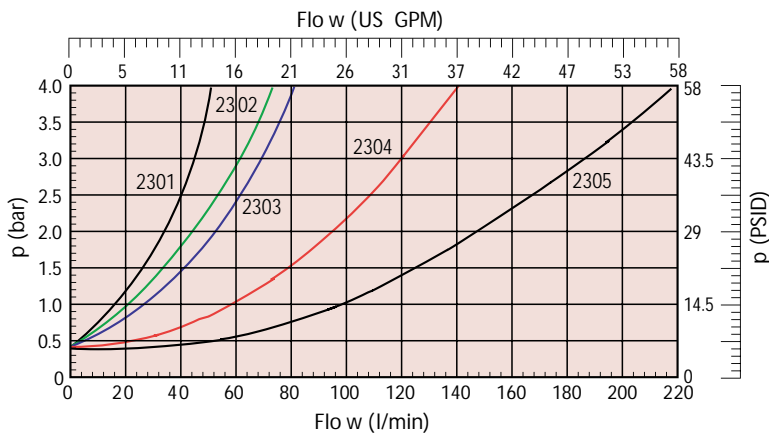

600013-...-... - Check valve for piping-system assembly

Valve crack pressures: 0.5 bar DN6 - DN40 (1/8" to 2")

Body:

Steel

Temperature:

-20 °C to + 100 °C

Cracking pressure:

0,5 bar*

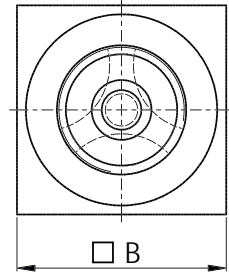
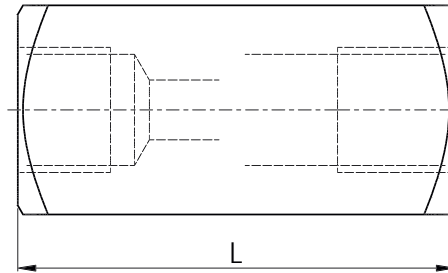
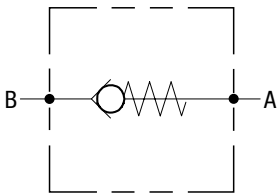

DN	Thread G	L (mm)	B (mm)	Weight kg/1 piece	Order code*	PN (bar)
06	G 1/8	45	16	0,10	600013-02-02	500
08	G 1/4	55	25	0,20	600013-04-04	500
10	G 3/8	65	30	0,40	600013-06-06	500
12	G 1/2	73	35	0,70	600013-08-08	500
16	G 3/4	88	45	1,20	600013-12-12	500
20	G1	127	50	2,00	600013-16-16	500
25	G 1 1/4	143	60	3,30	600013-20-20	400
30	G 1 1/2	143	70	4,20	600013-24-24	350
40	G 2	165	90	7,20	600013-32-32	350

*Option: Cracking pressure 4,5 bar

9049-.. - Flow control valve for piping-system assembly

DIN ISO 228 Female thread DN6 - DN40 (1/8" to 2")

Body:
Steel
O-rings:
NBR
Temperature:
-20 °C to + 100 °C

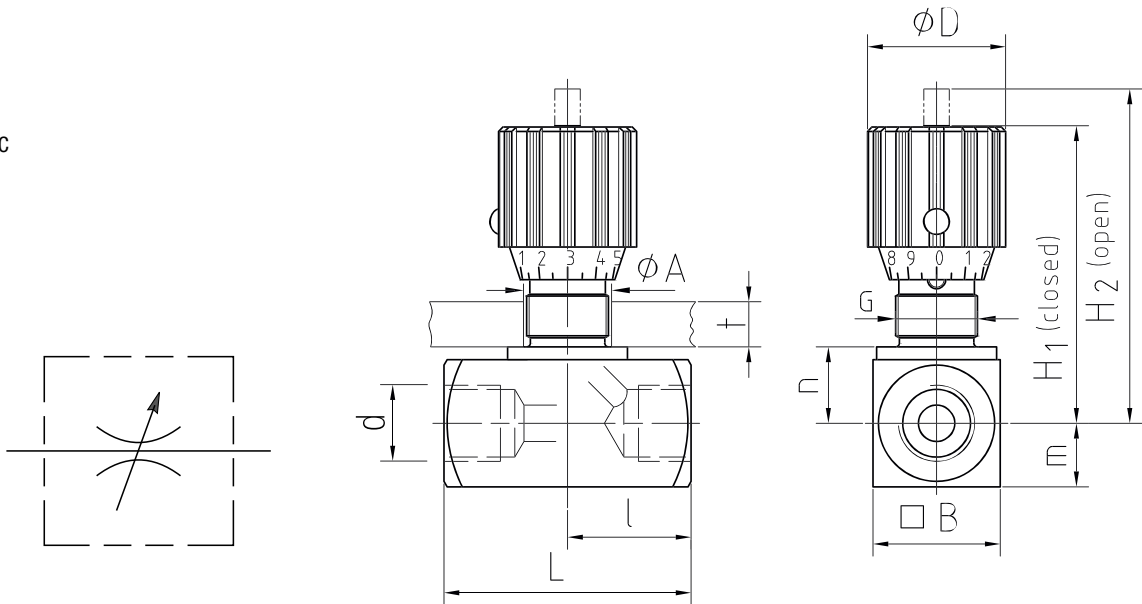

DN	H ₁	H ₂	m	n	B	l	L	D	A	d	G	t _{max}	Weight kg/1 piece	Order code	PN (bar)
06	51	56	8	10	16	19	38	24	13	G 1/8	Pg 7	4	0,12	9049-02	350
08	65	71	12,5	14,5	25	24	48	29	19	G 1/4	Pg 11	7	0,25	9049-04	350
10	68	75	15	17	30	29	58	29	19	G 3/8	Pg 11	7	0,40	9049-06	350
12	82	92	17,5	21	35	34	68	38	23	G 1/2	Pg 16	7	0,60	9049-08	350
16	96	106	2,5	26	45	39	78	38	23	G 3/4	Pg 16	7	1,10	9049-12	350
20	121	134	25	30	50	54	108	49	38	G 1	Pg 29	10	2,40	9049-16	350
25	126	139	30	35	60	54	108	49	38	G 1 1/4	Pg 29	10	2,80	9049-20	350
30	131	144	35	40	70	54	108	49	38	G 1 1/2	Pg 29	10	3,50	9049-24	350
40	141	154	45	50	90	60	120	49	38	G 2	Pg 29	10	6,24	9049-32	350

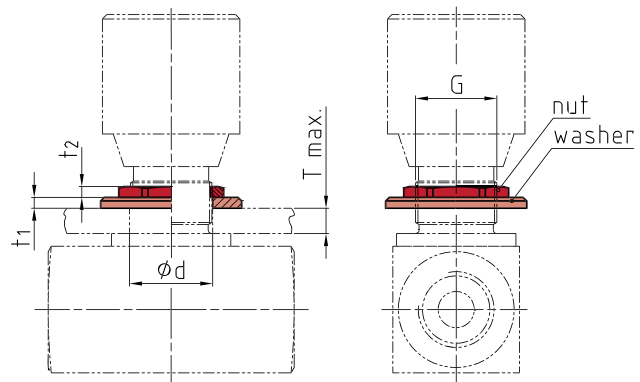

T _{max}	d	t ₁	t ₂	Thread	Diameter (mm)	Order code
4	13	2,5	2,8	Pg 7	12,5	9050-PG7
7	19	3	3	Pg 11	18,6	9050-PG11
7	23	3	3	Pg 16	22,5	9050-PG16
10	38	5	4	Pg 29	37,0	9050-PG29

9050-.. - Flow control check valve for piping-system assembly

DIN ISO 228 Female thread DN6 - DN40 (1/8" to 2")

Body:

Steel

O-rings:

NBR

Temperature:

-20 °C to + 100 °C

Cracking pressure:

0,5 bar*

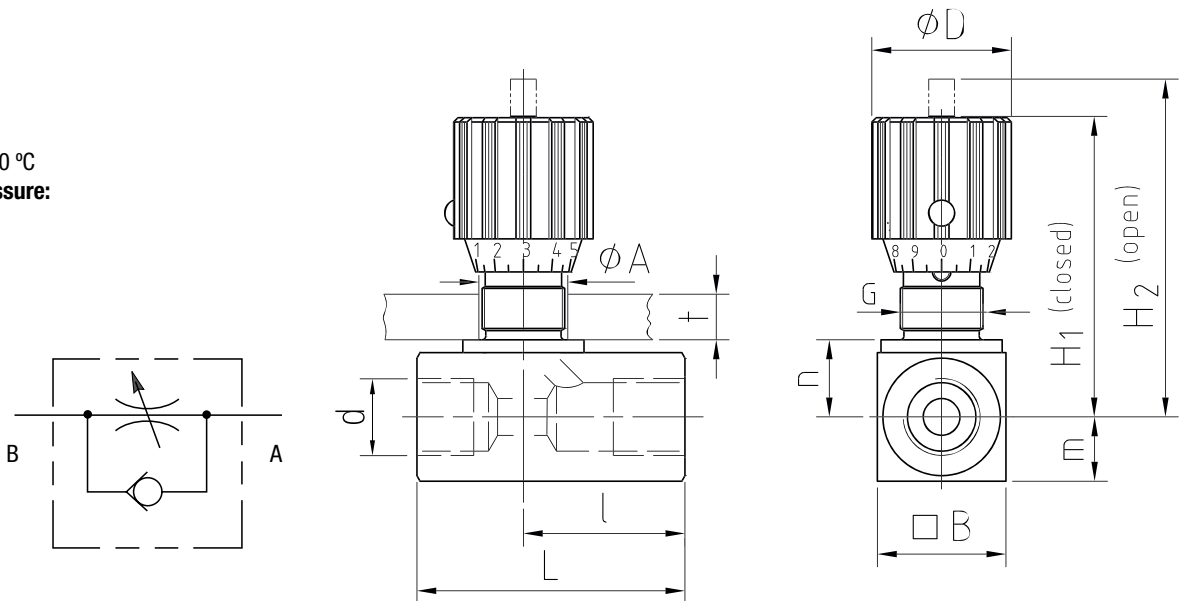

DN	H ₁	H ₂	m	n	B	l	L	D	A	d	G	t _{max}	Weight kg/1 piece	Order code	PN (bar)
06	51	56	8	10	16	26	45	24	13	G 1/8	Pg 7	4	0,12	9050-02	350
08	65	71	12,5	14,5	25	33,5	55	29	19	G 1/4	Pg 11	7	0,25	9050-04	350
10	68	75	15	17	30	41	65	29	19	G 3/8	Pg 11	7	0,40	9050-06	350
12	82	92	17,5	21	35	44	73	38	23	G 1/2	Pg 16	7	0,60	9050-08	350
16	96	106	2,5	26	45	57	88	38	23	G 3/4	Pg 16	7	1,10	9050-12	350
20	121	134	25	30	50	77	127	49	38	G 1	Pg 29	10	2,40	9050-16	350
25	126	139	30	35	60	93	143	49	38	G 1 1/4	Pg 29	10	2,80	9050-20	350
30	131	144	35	40	70	91	143	49	38	G 1 1/2	Pg 29	10	3,50	9050-24	350
40	141	154	45	50	90	111	165	49	38	G 2	Pg 29	10	6,24	9050-32	350

*Option: Cracking pressure 4,5 bar

SCV-.. - Speed control check valve

DIN ISO 228 Female thread

Body:

Brass 58

Temperature:

-20 °C to + 100 °C

Cracking pressure:

0,5 bar

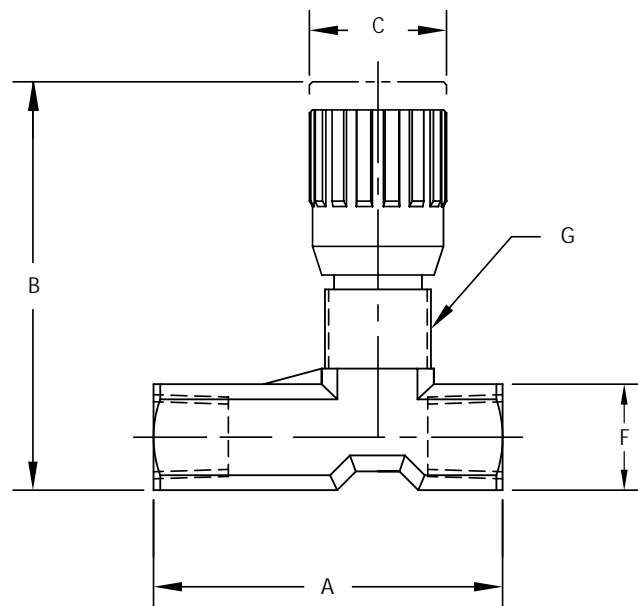
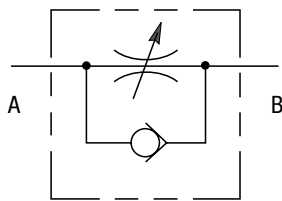

A	B	C	F	Panel mounting thread (G)	Thread	Weight kg/1 piece	Order code	PN (bar)
36	60	2	16,5	M17 x 1.0	G 1/4	0,13	SCV-1700	210
41,5	72,5	27	21,5	M 20 x 1,0	G 3/8	0,24	SCV-1701	210
57	85	33	27,0	M 25 x 1,5	G 1/2	0,45	SCV-1702	210

UC-.. - Speed control valve

DIN ISO 228 Female thread

Body:

Brass 58
(G 3/4 model-steel)

Temperature:

-20 °C to + 100 °C

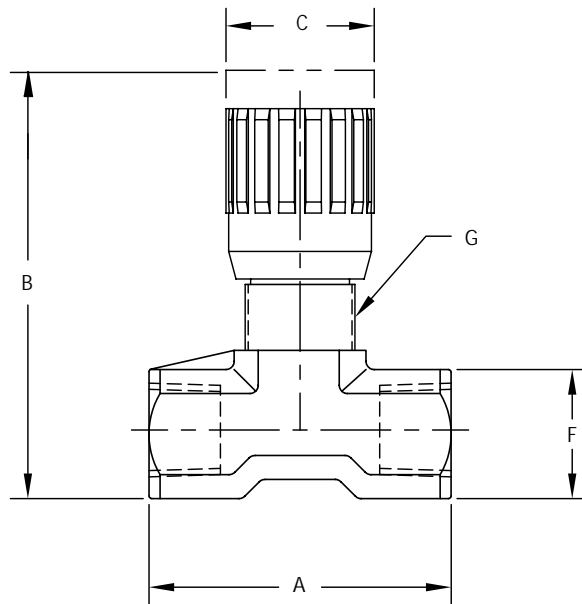
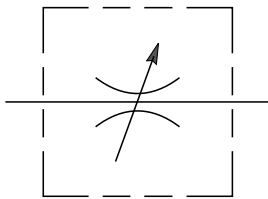

A	B	C	F	Panel mounting thread (G)	Thread	Weight kg/1 piece	Order code	PN (bar)
55,5	60	22	16,5	M17 x 1,0	G 1/4	0,13	UC-2000	210
64,5	72,5	27	21,5	M 20 x 1,0	G 3/8	0,24	UC-2001	210
87	85	33	27	M 25 x 1,5	G 1/2	0,45	UC-2002	210

Also Available...

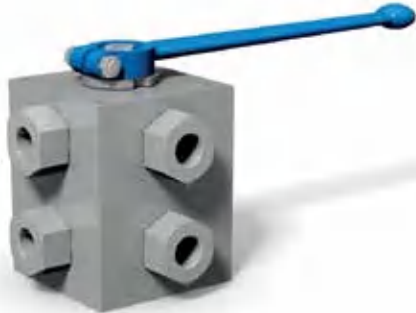

Multiway ball valve combinations



Multiway ball valve



3/2-way selector ball valve with SAE flange connection



Flow control valve for manifold mounting

Also Available...



Flow control valve for cartridge assembly



Check valve with SAE adapter



Ball valves with pneumatic actuator



Ball valves with electric actuator

Alphanumerical index

5060-08.....	36	5103-32-32.....	22	5119-20.....	11	5127-034-16.....	18
5060-12.....	36	5103N-08-08.....	25	5119-24.....	11	5127-035-20.....	18
5060-16.....	36	5103N-12-12.....	25	5119-32.....	11	5127-038-20.....	18
5060-20.....	36	5103N-16-16.....	25	5119-40.....	11	5127-038-24.....	18
5060-24.....	36	5103N-20-20.....	25	5119-48.....	11	5127-042-20.....	18
5060-32.....	36	5103N-24-24.....	25	5119-56.....	11	5127-042-24.....	18
5060-40.....	36	5103N-32-32.....	25	5119-64.....	11	5127-048-24.....	18
5060-48.....	36	5106-021-08.....	31	5119-80.....	11	5127-050-32.....	18
5060-56.....	36	5106-027-12.....	31	5120-08.....	11	5127-060-32.....	18
5060-64.....	36	5106-034-16.....	31	5120-12.....	11	5127-065-32.....	18
5060-80.....	36	5106-042-20.....	31	5120-16.....	11	5127-076-40.....	18
5061-08.....	36	5106-048-24.....	31	5120-20.....	11	5127-090-48.....	18
5061-12.....	36	5106-061-32.....	31	5120-24.....	11	5127-100-56.....	18
5061-16.....	36	5106-076-40.....	31	5120-32.....	11	5127-114-64.....	18
5061-20.....	36	5107-021-08.....	31	5120-40.....	11	5127-140-80.....	18
5061-24.....	36	5107-027-12.....	31	5120-48.....	11	5128-016-08.....	19
5061-32.....	36	5107-034-16.....	31	5125-015-08.....	18	5128-016-12.....	19
5061-40.....	36	5107-042-20.....	31	5125-016-08.....	18	5128-020-12.....	19
5061-48.....	36	5107-048-24.....	31	5125-018-12.....	18	5128-021-08.....	19
5062-08.....	35	5107-061-32.....	31	5125-020-12.....	18	5128-025-12.....	19
5062-12.....	35	5112-16.....	37	5125-020-16.....	18	5128-025-16.....	19
5062-16.....	35	5112-20.....	37	5125-021-08.....	18	5128-027-12.....	19
5062-20.....	35	5112-24.....	37	5125-022-12.....	18	5128-030-16.....	19
5062-24.....	35	5112-32.....	37	5125-025-12.....	18	5128-030-20.....	19
5062-32.....	35	5112-40.....	37	5125-025-20.....	18	5128-034-16.....	19
5062-40.....	35	5112-48.....	37	5125-027-12.....	18	5128-038-20.....	19
5062-48.....	35	5112-56.....	37	5125-028-16.....	18	5128-038-24.....	19
5062-56.....	35	5112-64.....	37	5125-030-16.....	18	5128-042-20.....	19
5062-64.....	35	5112-80.....	37	5125-030-20.....	18	5128-048-24.....	19
5062-80.....	35	5113-16.....	37	5125-034-16.....	18	5128-050-32.....	19
5063-08.....	35	5113-20.....	37	5125-035-20.....	18	5128-061-32.....	19
5063-12.....	35	5113-24.....	37	5125-038-20.....	18	5128-065-32.....	19
5063-16.....	35	5113-32.....	37	5125-038-24.....	18	5128-073-40.....	19
5063-20.....	35	5113-40.....	37	5125-042-20.....	18	5128-089-48.....	19
5063-24.....	35	5113-48.....	37	5125-042-24.....	18	5130-37.....	7
5063-32.....	35	5115-08.....	9	5125-048-24.....	18	5130-37VIT.....	7
5063-40.....	35	5115-12.....	9	5125-050-32.....	18	5130-51.....	7
5063-48.....	35	5115-16.....	9	5125-060-32.....	18	5130-51VIT.....	7
5064-08.....	34	5115-20.....	9	5125-065-32.....	18	5130-61.....	7
5064-12.....	34	5115-24.....	9	5125-076-40.....	18	5130-61VIT.....	7
5064-16.....	34	5115-32.....	9	5125-090-48.....	18	5130-67.....	7
5064-20.....	34	5115-40.....	9	5125-100-56.....	18	5130-67VIT.....	7
5064-24.....	34	5115-48.....	9	5125-114-64.....	18	5130-73.....	7
5064-32.....	34	5115-56.....	9	5125-140-80.....	18	5130-73VIT.....	7
5064-40.....	34	5115-64.....	9	5126-016-08.....	19	5130-75.....	7
5064-48.....	34	5115-80.....	9	5126-016-12.....	19	5130-75VIT.....	7
5064-56.....	34	5116-08.....	9	5126-020-12.....	19	5130-79.....	7
5064-64.....	34	5116-12.....	9	5126-021-08.....	19	5130-79VIT.....	7
5064-80.....	34	5116-12.....	9	5126-025-12.....	19	5130-81.....	7
5065-08.....	34	5116-20.....	9	5126-025-16.....	19	5130-81VIT.....	7
5065-12.....	34	5116-24.....	9	5126-027-12.....	19	5130-83.....	7
5065-16.....	34	5116-32.....	9	5126-030-16.....	19	5130-83VIT.....	7
5065-20.....	34	5116-40.....	9	5126-030-20.....	19	5130-85.....	7
5065-24.....	34	5116-48.....	9	5126-034-16.....	19	5130-85VIT.....	7
5065-32.....	34	5117-08.....	10	5126-038-20.....	19	5130-87.....	7
5065-40.....	34	5117-12.....	10	5126-038-24.....	19	5130-87VIT.....	7
5065-48.....	34	5117-16.....	10	5126-042-20.....	19	5138-017-08.....	29
5102-08-08.....	22	5117-20.....	10	5126-048-24.....	19	5138-021-08.....	29
5102-12-12.....	22	5117-24.....	10	5126-050-32.....	19	5138-027-12.....	29
5102-16-16.....	22	5117-32.....	10	5126-061-32.....	19	5138-034-16.....	29
5102-20-20.....	22	5117-40.....	10	5126-065-32.....	19	5138-040-80.....	29
5102-24-24.....	22	5117-48.....	10	5126-073-40.....	19	5138-042-20.....	29
5102-32-32.....	22	5117-56.....	10	5126-089-48.....	19	5138-048-24.....	29
5102-40-40.....	22	5117-64.....	10	5127-015-08.....	18	5138-060-32.....	29
5102N-08-08.....	25	5117-80.....	10	5127-016-08.....	18	5138-076-40.....	29
5102N-12-12.....	25	5118-08.....	10	5127-018-12.....	18	5138-090-48.....	29
5102N-16-16.....	25	5118-12.....	10	5127-020-12.....	18	5138-103-56.....	29
5102N-20-20.....	25	5118-16.....	10	5127-020-16.....	18	5138-115-64.....	29
5102N-24-24.....	25	5118-20.....	10	5127-021-08.....	18	5139-017-08.....	29
5102N-32-32.....	25	5118-24.....	10	5127-022-12.....	18	5139-021-08.....	29
5102N-40-40.....	25	5118-32.....	10	5127-025-12.....	18	5139-027-12.....	29
5103-08-08.....	22	5118-40.....	10	5127-025-20.....	18	5139-034-16.....	29
5103-12-12.....	22	5118-48.....	10	5127-027-12.....	18	5139-042-20.....	29
5103-16-16.....	22	5119-08.....	11	5127-028-16.....	18	5139-048-24.....	29
5103-20-20.....	22	5119-12.....	11	5127-030-16.....	18	5139-060-32.....	29
5103-24-24.....	22	5119-16.....	11	5127-030-20.....	18	5139-076-40.....	29

5139-090-48.....	29	5147-20.....	32	5151N-32-32.....	23	9001-10.....	103
5140-017-08.....	30	5147-24.....	32	5151N-40-40.....	23	9001-12.....	103
5140-021-08.....	30	5147-32.....	32	5151N-48-48.....	23	9001-16.....	103
5140-027-12.....	30	5147-40.....	32	5152-06-08.....	21	9001-20.....	103
5140-034-16.....	30	5147-48.....	32	5152-08-08.....	21	9001-20-DN32.....	103
5140-042-20.....	30	5148-08.....	33	5152-08-12.....	21	9001-24.....	103
5140-048-24.....	30	5148-12.....	33	5152-12-12.....	21	9001-32.....	103
5140-061-32.....	30	5148-16.....	33	5152-12-16.....	21	9002-06.....	104
5140-076-40.....	30	5148-20.....	33	5152-16-16.....	21	9002-08.....	104
5140-090-48.....	30	5148-24.....	33	5152-16-20.....	21	9002-10.....	104
5140-103-56.....	30	5148-32.....	33	5152-20-20.....	21	9002-12.....	104
5140-115-64.....	30	5148-40.....	33	5152-20-24.....	21	9002-15.....	104
5140-140-80.....	30	5148-48.....	33	5152-24-24.....	21	9002-18.....	104
5141-017-08.....	30	5148-56.....	33	5152-24-32.....	21	9002-22.....	104
5141-021-08.....	30	5148-64.....	33	5152-32-32.....	21	9002-28.....	104
5141-027-12.....	30	5148-80.....	33	5152-32-40.....	21	9002-35.....	104
5141-034-16.....	30	5149-08.....	33	5152-40-40.....	21	9003-08.....	105
5141-042-20.....	30	5149-12.....	33	5152-40-48.....	21	9003-10.....	105
5141-048-24.....	30	5149-16.....	33	5152-48-48.....	21	9003-12.....	105
5141-061-32.....	30	5149-20.....	33	5152-48-56.....	21	9003-14.....	105
5141-076-40.....	30	5149-24.....	33	5152-56-56.....	21	9003-16.....	105
5141-090-48.....	30	5149-32.....	33	5152-56-64.....	21	9003-20.....	105
5142-021-08.....	26	5149-40.....	33	5152-64-64.....	21	9003-25.....	105
5142-028-12.....	26	5149-48.....	33	5152-80-80.....	21	9003-30.....	105
5142-034-16.....	26	5150-06-08.....	20	5152N-06-08.....	24	9003-38.....	105
5142-042-20.....	26	5150-08-08.....	20	5152N-08-08.....	24	9004-02.....	103
5142-048-24.....	26	5150-08-12.....	20	5152N-12-12.....	24	9004-04.....	103
5142-061-32.....	26	5150-12-12.....	20	5152N-16-16.....	24	9004-06.....	103
5142-077-40.....	26	5150-12-16.....	20	5152N-20-20.....	24	9004-08.....	103
5142-092-48.....	26	5150-16-16.....	20	5152N-24-24.....	24	9004-10.....	103
5142-103-56.....	26	5150-16-20.....	20	5152N-32-32.....	24	9004-12.....	103
5142-115-64.....	26	5150-20-20.....	20	5152N-40-40.....	24	9004-16.....	103
5142-140-80.....	26	5150-20-24.....	20	5152N-48-48.....	24	9004-20.....	103
5143-017-08.....	26	5150-24-24.....	20	5152N-56-56.....	24	9004-20-DN32.....	103
5143-021-08.....	26	5150-24-32.....	20	5152N-64-64.....	24	9004-24.....	103
5143-028-12.....	26	5150-32-32.....	20	5152N-80-80.....	24	9004-32.....	103
5143-034-16.....	26	5150-32-40.....	20	5153-06-08.....	21	9005-06.....	104
5143-042-20.....	26	5150-40-40.....	20	5153-08-08.....	21	9005-08.....	104
5143-048-24.....	26	5150-40-48.....	20	5153-08-12.....	21	9005-10.....	104
5143-061-32.....	26	5150-48-48.....	20	5153-12-12.....	21	9005-12.....	104
5143-076-40.....	26	5150-48-56.....	20	5153-12-16.....	21	9005-15.....	104
5143-090-48.....	26	5150-56-56.....	20	5153-16-16.....	21	9005-18.....	104
5144-021-08.....	27	5150-56-64.....	20	5153-16-20.....	21	9005-22.....	104
5144-028-12.....	27	5150-64-64.....	20	5153-20-20.....	21	9005-28.....	104
5144-034-16.....	27	5150-80-80.....	20	5153-20-24.....	21	9005-35.....	104
5144-042-20.....	27	5150N-06-08.....	23	5153-24-24.....	21	9006-08.....	105
5144-048-24.....	27	5150N-08-08.....	23	5153-24-32.....	21	9006-10.....	105
5144-061-32.....	27	5150N-12-12.....	23	5153-32-32.....	21	9006-12.....	105
5144-077-40.....	27	5150N-16-16.....	23	5153-40-40.....	21	9006-14.....	105
5144-092-48.....	27	5150N-20-20.....	23	5153-48-48.....	21	9006-16.....	105
5144-103-56.....	27	5150N-24-24.....	23	5153N-06-08.....	24	9006-20.....	105
5144-115-64.....	27	5150N-32-32.....	23	5153N-08-08.....	24	9006-25.....	105
5144-140-80.....	27	5150N-40-40.....	23	5153N-12-12.....	24	9006-30.....	105
5145-017-08.....	27	5150N-48-48.....	23	5153N-16-16.....	24	9006-38.....	105
5145-021-08.....	27	5150N-56-56.....	23	5153N-20-20.....	24	9011-04Z.....	92
5145-028-12.....	27	5150N-64-64.....	23	5153N-24-24.....	24	9011-06Z.....	92
5145-034-16.....	27	5150N-80-80.....	23	5153N-32-32.....	24	9011-08.....	92
5145-042-20.....	27	5151-06-08.....	20	5153N-40-40.....	24	9011-08Z.....	92
5145-048-24.....	27	5151-08-08.....	20	5153N-48-48.....	24	9011-12.....	92
5145-061-32.....	27	5151-08-12.....	20	5167-021-08.....	28	9011-12Z.....	92
5145-076-40.....	27	5151-12-12.....	20	5167-027-12.....	28	9011-16.....	92
5145-090-48.....	27	5151-12-16.....	20	5167-034-16.....	28	9011-16Z.....	92
5146-08.....	32	5151-16-16.....	20	5167-042-20.....	28	9011-20.....	92
5146-12.....	32	5151-20-20.....	20	5167-048-24.....	28	9011-20Z.....	92
5146-16.....	32	5151-20-24.....	20	5167-060-32.....	28	9011-24.....	92
5146-20.....	32	5151-24-24.....	20	5167-076-40.....	28	9011-24Z.....	92
5146-24.....	32	5151-24-32.....	20	5168-021-08.....	28	9011-32.....	92
5146-32.....	32	5151-32-32.....	20	5168-027-12.....	28	9011-32Z.....	92
5146-40.....	32	5151-40-40.....	20	5168-034-16.....	28	9012-08.....	93
5146-48.....	32	5151-48-48.....	20	5168-042-20.....	28	9012-12.....	93
5146-56.....	32	5151N-06-08.....	23	5168-048-24.....	28	9012-16.....	93
5146-64.....	32	5151N-08-08.....	23	5168-060-32.....	28	9012-20.....	93
5146-80.....	32	5151N-12-12.....	23	9001-02.....	103	9012-24.....	93
5147-08.....	32	5151N-16-16.....	23	9001-04.....	103	9012-32.....	93
5147-12.....	32	5151N-20-20.....	23	9001-06.....	103	9012-40.....	93
5147-16.....	32	5151N-24-24.....	23	9001-08.....	103	9012-48.....	93

Alphanumerical index

9012-64.....	93	9021-40.....	119	9032-30.....	110	9048-12.....	117
9013-04.....	93	9021-48.....	119	9032-38.....	110	9048-14.....	117
9013-06.....	93	9022-08.....	120	9033-02.....	107	9048-16.....	117
9013-08.....	93	9022-12.....	120	9033-04.....	107	9048-20.....	117
9013-12.....	93	9022-16.....	120	9033-06.....	107	9048-25.....	117
9013-16.....	93	9022-20.....	120	9033-08.....	107	9048-30.....	117
9013-20.....	93	9022-24.....	120	9033-10.....	107	9048-38.....	117
9013-24.....	93	9022-32.....	120	9033-12.....	107	9049-02.....	130
9013-32.....	93	9023-08.....	121	9033-16.....	107	9049-04.....	130
9013-40.....	93	9023-12.....	121	9033-20.....	107	9049-06.....	130
9013-48.....	93	9023-16.....	121	9033-24.....	107	9049-08.....	130
9013-64.....	93	9023-20.....	121	9034-06.....	109	9049-12.....	130
9014-02.....	98	9023-24.....	121	9034-08.....	109	9049-16.....	130
9014-04.....	98	9023-32.....	121	9034-10.....	109	9049-20.....	130
9014-06.....	98	9024-08.....	122	9034-12.....	109	9049-24.....	130
9014-08.....	98	9024-12.....	122	9034-15.....	109	9049-32.....	130
9014-10.....	98	9024-16.....	122	9034-18.....	109	9050-02.....	131
9014-12.....	98	9024-20.....	122	9034-22.....	109	9050-04.....	131
9014-16.....	98	9024-24.....	122	9034-28.....	109	9050-06.....	131
9014-16-PN420.....	98	9024-32.....	122	9034-35.....	109	9050-08.....	131
9014-20.....	98	9025-08.....	123	9035-08.....	111	9050-12.....	131
9014-24.....	98	9025-12.....	123	9035-10.....	111	9050-16.....	131
9015-02.....	98	9025-16.....	123	9035-12.....	111	9050-20.....	131
9015-04.....	98	9025-20.....	123	9035-14.....	111	9050-24.....	131
9015-06.....	98	9025-24.....	123	9035-16.....	111	9050-32.....	131
9015-08.....	98	9025-32.....	123	9035-20.....	111	9050-PG7.....	130
9015-12.....	98	9026-08.....	124	9035-25.....	111	9050-PG11.....	130
9015-16.....	98	9026-12.....	124	9035-30.....	111	9050-PG16.....	130
9015-16-PN420.....	98	9026-16.....	124	9035-38.....	111	9050-PG29.....	130
9015-20.....	98	9026-20.....	124	9043-02.....	112	9114-01.....	126
9015-24.....	98	9026-24.....	124	9043-04.....	112	9114-02.....	126
9016-06.....	99	9026-32.....	124	9043-06.....	112	9114-09.....	127
9016-08.....	99	9027-08.....	125	9043-08.....	112	9114-10.....	127
9016-10.....	99	9027-12.....	125	9043-10.....	112	9114-12.....	127
9016-12.....	99	9027-16.....	125	9043-12.....	112	9114-13.....	127
9016-15.....	99	9027-20.....	125	9043-16.....	112	9114-19.....	126
9016-18.....	99	9027-24.....	125	9043-20.....	112	9114-19RVS.....	126
9016-18-DN13.....	99	9027-32.....	125	9043-24.....	112	9114-30.....	127
9016-22.....	99	9028-04.....	102	9044-06.....	113	9117-21.....	126
9016-28.....	99	9028-06.....	102	9044-08.....	113	9117-21RVS.....	126
9016-35.....	99	9028-08.....	102	9044-10.....	113	9117-22.....	126
9016-42.....	99	9028-12.....	102	9044-12.....	113	9117-22RVS.....	126
9017-08.....	99	9028-16.....	102	9044-15.....	113	089231.....	79
9017-10.....	99	9029-08.....	102	9044-18.....	113	089241.....	79
9017-12.....	99	9029-10.....	102	9044-22.....	113	089251.....	79
9017-14.....	99	9029-12.....	102	9044-28.....	113	089261.....	79
9017-16.....	99	9029-14.....	102	9044-35.....	113	089271.....	74
9017-20.....	99	9029-16.....	102	9045-08.....	114	089271.....	79
9017-20-DN13.....	99	9029-20.....	102	9045-10.....	114	090001.....	74
9017-25.....	99	9029-25.....	102	9045-12.....	114	090001.....	74
9017-30.....	99	9029-30.....	102	9045-14.....	114	090011.....	74
9017-30-PN420.....	99	9030-02.....	106	9045-16.....	114	090011.....	91
9017-38.....	99	9030-04.....	106	9045-20.....	114	090021.....	74
9018-20.....	100	9030-06.....	106	9045-25.....	114	090031.....	74
9018-20NPT.....	100	9030-08.....	106	9045-30.....	114	090031.....	91
9018-24.....	100	9030-10.....	106	9045-38.....	114	090032.....	74
9018-24NPT.....	100	9030-12.....	106	9046-02.....	115	090040.....	74
9018-32.....	100	9030-16.....	106	9046-04.....	115	090050.....	74
9018-32NPT.....	100	9030-20.....	106	9046-06.....	115	090050.....	91
9019-35.....	101	9030-24.....	106	9046-08.....	115	090060.....	74
9019-38.....	101	9031-06.....	108	9046-10.....	115	090070.....	74
9019-42.....	101	9031-08.....	108	9046-12.....	115	090080.....	74
9020-08.....	118	9031-10.....	108	9046-16.....	115	090080.....	91
9020-12.....	118	9031-12.....	108	9046-20.....	115	090081.....	74
9020-16.....	118	9031-15.....	108	9046-24.....	115	090082.....	74
9020-20.....	118	9031-18.....	108	9047-06.....	116	090091.....	74
9020-24.....	118	9031-22.....	108	9047-08.....	116	090091.....	74
9020-32.....	118	9031-28.....	108	9047-10.....	116	090092.....	74
9020-40.....	118	9031-35.....	108	9047-12.....	116	090093.....	74
9020-48.....	118	9032-08.....	110	9047-15.....	116	090101.....	74
9021-08.....	119	9032-10.....	110	9047-18.....	116	090101.....	77
9021-12.....	119	9032-12.....	110	9047-22.....	116	090101.....	91
9021-16.....	119	9032-14.....	110	9047-28.....	116	090111.....	74
9021-20.....	119	9032-16.....	110	9047-35.....	116	090121.....	74
9021-24.....	119	9032-20.....	110	9048-08.....	117	090131.....	74
9021-32.....	119	9032-25.....	110	9048-10.....	117	090131.....	91

090141.....	83	390026.....	70	390148.....	81	390928.....	77
090151.....	83	390027.....	70	390149.....	81	390929.....	77
090161.....	83	390028.....	70	390150.....	81	390930.....	77
090181.....	83	390029.....	70	390151.....	81	390931.....	83
090191.....	83	390032.....	70	390152.....	81	390932.....	83
090201.....	83	390034.....	70	390153.....	81	390933.....	83
090211.....	83	390035.....	70	390154.....	81	390934.....	83
090231.....	77	390037.....	70	390155.....	81	390935.....	83
090241.....	77	390038.....	70	390156.....	81	390936.....	83
090251.....	77	390040.....	70	390157.....	81	390937.....	83
090261.....	77	390044.....	70	390158.....	81	390938.....	83
090270.....	75	390045.....	70	390159.....	81	390939.....	83
090270.....	75	390046.....	70	390160.....	81	390940.....	83
090270.....	79	390047.....	70	390162.....	81	390941.....	83
090280.....	75	390048.....	70	390163.....	81	390942.....	83
090290.....	75	390050.....	70	390164.....	81	390943.....	83
090300.....	75	390051.....	70	390165.....	81	390944.....	83
090310.....	75	390052.....	70	390166.....	81	390945.....	83
090330.....	79	390060.....	71	390167.....	80	390946.....	83
090340.....	79	390061.....	71	390168.....	80	390947.....	74
090350.....	79	390062.....	71	390200.....	76	390947.....	91
090360.....	79	390063.....	71	390201.....	76	390948.....	74
090361.....	75	390064.....	71	390201.....	82	390949.....	74
090401.....	83	390065.....	71	390202.....	76	390950.....	74
090510.....	84	390070.....	71	390203.....	76	390950.....	91
090520.....	84	390071.....	71	390204.....	76	390951.....	74
090530.....	84	390099.....	80	390204.....	86	390952.....	74
090540.....	84	390100.....	80	390205.....	76	390953.....	76
090550.....	84	390101.....	80	390206.....	76	390954.....	76
090560.....	84	390102.....	80	390207.....	76	390955.....	76
090570.....	84	390103.....	80	390208.....	76	390956.....	76
090580.....	84	390104.....	80	390209.....	76	390957.....	76
090600.....	75	390105.....	80	390210.....	76	390958.....	82
090600.....	91	390106.....	80	390211.....	76	390959.....	82
090700.....	7	390107.....	80	390212.....	76	390960.....	82
090700.....	7	390108.....	80	390213.....	76	390961.....	82
090701.....	7	390109.....	80	390214.....	76	390962.....	82
090730.....	7	390110.....	80	390215.....	76	390963.....	82
090730.....	7	390111.....	80	390218.....	76	390964.....	82
090730.....	7	390112.....	80	390219.....	76	390965.....	82
090731.....	7	390113.....	80	390220.....	76	390966.....	82
090750.....	7	390114.....	80	390225.....	76	390967.....	82
090760.....	7	390115.....	80	390226.....	76	390968.....	82
090770.....	7	390116.....	80	390227.....	76	390969.....	82
090771.....	7	390116-2.....	80	390228.....	76	390970.....	82
090790.....	7	390117.....	80	390235.....	76	390971.....	82
090791.....	7	390118.....	80	390237.....	76	390972.....	82
090800.....	7	390119.....	80	390238.....	76	390973.....	82
090801.....	7	390120.....	80	390510.....	84	390974.....	72
090810.....	7	390121.....	80	390520.....	84	390975.....	72
090820.....	7	390122.....	80	390530.....	84	390977.....	72
090821.....	7	390123.....	80	390540.....	84	390978.....	91
390000.....	70	390124.....	80	390550.....	84	390979.....	72
390001.....	70	390125.....	80	390560.....	84	390980.....	72
390002.....	70	390126.....	80	390570.....	84	390981.....	72
390003.....	70	390127.....	80	390580.....	84	390982.....	72
390004.....	70	390128.....	80	390894.....	73	390983.....	72
390005.....	70	390129.....	80	390895.....	73	390984.....	72
390006.....	70	390130.....	80	390896.....	73	390985.....	72
390007.....	70	390131.....	80	390897.....	73	390986.....	72
390008.....	70	390132.....	80	390898.....	73	390987.....	72
390009.....	70	390133.....	80	390899.....	73	390988.....	72
390010.....	70	390134.....	80	390904.....	73	390989.....	72
390011.....	70	390135.....	80	390904.....	78	390990.....	72
390012.....	70	390136.....	80	390906.....	78	390991.....	72
390013.....	70	390137.....	81	390907.....	83	390992.....	72
390014.....	70	390138.....	81	390908.....	83	390993.....	72
390015.....	70	390139.....	81	390913.....	78	390994.....	70
390016.....	70	390140.....	81	390914.....	73	390995.....	70
390017.....	70	390141.....	81	390914.....	78	390996.....	70
390018.....	70	390141-5.....	81	390915.....	73	390997.....	70
390019.....	70	390142.....	81	390918.....	79	390998.....	70
390020.....	70	390143.....	81	390919.....	79	390999.....	70
390021.....	70	390144.....	81	390925.....	75	391000.....	70
390022.....	70	390145.....	81	390926.....	77	391001.....	72
390025.....	70	390147.....	81	390927.....	77	391002.....	72

391003.....	72	392222.....	86	395120E.....	89	BFW-G112/LK55.....	43
391004.....	72	392223.....	86	395121E.....	89	BFW-G134/LK40.....	43
391005.....	72	392224.....	86	395125E.....	89	BFW-G134/LK55.....	43
391007.....	71	392927.....	86	600013-02-02.....	129	BFW-G138/LK35.....	43
391008.....	71	392928.....	86	600013-04-04.....	129	BFW-G138/LK40.....	43
391043.....	74	392929.....	86	600013-06-06.....	129	BVG4P-1/2LOCK.....	95
391044.....	74	392930.....	86	600013-08-08.....	129	BVG4P-1/4LOCK.....	95
391045.....	74	393004.....	91	600013-12-12.....	129	BVG4P-1LOCK.....	95
391800.....	73	393005.....	91	600013-16-16.....	129	BVG4P-3/4LOCK.....	95
392001.....	85	393006.....	91	600013-20-20.....	129	BVG4P-3/8LOCK.....	95
392001PA.....	85	393007.....	91	600013-24-24.....	129	EE12X.....	88
392002.....	85	393008.....	91	600013-32-32.....	129	EE15X.....	88
392002PA.....	85	393009.....	91	3909745.....	78	EE20X.....	88
392003.....	85	393010.....	91	3909754.....	78	EE25X.....	88
392003PA.....	85	393011.....	91	3909773.....	78	EE30X.....	88
392004.....	85	393012.....	91	3909792.....	78	EE35X.....	88
392004PA.....	85	393013.....	91	3909801.....	78	EE38X.....	88
392005.....	85	393014.....	91	BFG10L/LK35.....	39	EE42X.....	88
392005PA.....	85	393015.....	91	BFG12L/LK35.....	39	EE206/406X.....	89
392006.....	85	393016.....	91	BFG15L/LK35.....	39	EE208/408X.....	89
392006PA.....	85	393017.....	91	BFG15L/LK40.....	39	EE210/410X.....	89
392007.....	85	393018.....	91	BFG16S/LK35.....	39	EE212.7/412.7X.....	89
392007PA.....	85	393019.....	91	BFG18L/LK40.....	39	EE212/412X.....	89
392008.....	85	393020.....	91	BFG20S/LK55.....	39	EE214/414X.....	89
392008PA.....	85	393021.....	91	BFG22L/LK40.....	39	EE215/415X.....	89
392009.....	85	393022.....	91	BFG28L/LK40.....	39	EE216/416X.....	89
392009PA.....	85	393025.....	91	BFW3-12L/LK30.....	41	EE217.2/417.2X.....	89
392010.....	85	393026.....	91	BFW3-15L/LK30.....	41	EE218/418X.....	89
392010PA.....	85	393027.....	91	BFW3-18L/LK30.....	41	EE219/419X.....	89
392011.....	85	393028.....	91	BFW3-22L/LK40.....	41	EE320/620X.....	89
392011PA.....	85	393029.....	91	BFW3-28L/LK40.....	41	EE321.3/621.3X.....	89
392012.....	85	393035.....	91	BFW3-G1/LK51.....	44	EE322/622X.....	89
392012PA.....	85	393037.....	91	BFW3-G1/LK56.....	44	EE323/623X.....	89
392013.....	85	393038.....	91	BFW3-G1/LK62.....	44	EE325/625X.....	89
392013PA.....	85	393040.....	91	BFW3-G1/LK62/12.....	44	EE326.9/626.9X.....	89
392014.....	85	393979.....	91	BFW3-G12/LK26.....	44	EE328/628X.....	89
392014PA.....	85	394004E.....	89	BFW3-G12/LK30.....	44	EE330/630X.....	89
392015.....	85	394005E.....	89	BFW3-G12/LK40.....	44	EE332/632X.....	89
392015PA.....	85	394006E.....	89	BFW3-G34/LK40.....	44	EE432X.....	89
392016.....	85	394007E.....	89	BFW3-G34/LK51.....	44	EE433.7X.....	89
392016PA.....	85	394008E.....	89	BFW3-G34/LK56.....	44	EE435X.....	89
392017.....	85	394009E.....	89	BFW3-G38/LK26.....	44	EE438X.....	89
392017PA.....	85	394010E.....	89	BFW3-G38/LK30.....	44	EE440X.....	89
392018.....	85	394011E.....	89	BFW3-G112/LK72.5.....	44	EE442X.....	89
392018PA.....	85	394012E.....	89	BFW3-G114/LK62.....	44	EE445.5X.....	89
392019.....	85	394013E.....	89	BFW3-G114/LK62/12.....	44	EE448X.....	89
392019PA.....	85	394014E.....	89	BFW3-G114/LK72.5.....	44	EE451X.....	89
392020.....	85	394015E.....	89	BFW10L/LK35.....	40	EE453.4X.....	89
392020PA.....	85	394016E.....	89	BFW12L/LK35.....	40	EE456.4X.....	89
392021.....	85	394017E.....	89	BFW15L/LK35.....	40	GFS32/12G.....	16
392021PA.....	85	394018E.....	89	BFW15L/LK40.....	40	GFS32/15L.....	12
392022.....	85	394026E.....	89	BFW16S/LK35.....	40	GFS32/16S.....	12
392022PA.....	85	394027E.....	89	BFW18L/LK40.....	40	GFS32/18L.....	12
392023.....	85	394028E.....	89	BFW20S/LK35.....	40	GFS32/38G.....	16
392023PA.....	85	394038E.....	89	BFW20S/LK40.....	40	GFS33/12G.....	16
392024.....	85	394040E.....	89	BFW20S/LK55.....	40	GFS33/16S.....	12
392201.....	86	395099E.....	89	BFW22L/LK40.....	40	GFS33/18L.....	12
392202.....	86	395100E.....	89	BFW25S/LK55.....	40	GFS33/20S.....	12
392203.....	86	395101E.....	89	BFW28L/LK40.....	40	GFS33/22L.....	12
392205.....	86	395102E.....	89	BFW30S/LK55.....	40	GFS33/25S.....	12
392206.....	86	395104E.....	89	BFW35L/LK40.....	40	GFS33/28L.....	12
392207.....	86	395105E.....	89	BFW35L/LK55.....	40	GFS33/34G.....	16
392208.....	86	395106E.....	89	BFW42L/LK55.....	40	GFS34/1G.....	16
392209.....	86	395107E.....	89	BFW-G1/LK40.....	42	GFS34/20S.....	12
392210.....	86	395108E.....	89	BFW-G1/LK55.....	42	GFS34/25S.....	12
392211.....	86	395109E.....	89	BFW-G12/LK35.....	42	GFS34/28L.....	12
392212.....	86	395110E.....	89	BFW-G12/LK40.....	42	GFS34/30S.....	12
392213.....	86	395111E.....	89	BFW-G12/LK55.....	42	GFS34/34G.....	16
392214.....	86	395112E.....	89	BFW-G34/LK35.....	42	GFS34/42L.....	12
392215.....	86	395113E.....	89	BFW-G34/LK40.....	42	GFS35/1G.....	16
392216.....	86	395114E.....	89	BFW-G34/LK55.....	42	GFS35/25S.....	12
392217.....	86	395115E.....	89	BFW-G38/LK35.....	42	GFS35/25S/10.....	12
392218.....	86	395116E.....	89	BFW-G38/LK40.....	42	GFS35/28L.....	12
392219.....	86	395117E.....	89	BFW-G11/LK55.....	43	GFS35/30S.....	12
392220.....	86	395118E.....	89	BFW-G112/LK35.....	43	GFS35/30S/10.....	12
392221.....	86	395119E.....	89	BFW-G112/LK40.....	43	GFS35/35L.....	12

Alphanumerical index

GFS35/35L/10	12	HSRS50	88	R06X1	48	R15X1.5CF	48
GFS35/38S	12	MBVG4-1/2	97	R06X1.5	48	R15X1.5ST52CF	50
GFS35/38S/10	12	MBVG4-1/4	97	R06X1.5-316BA	52	R15X1.571	51
GFS35/114G	16	MBVG4-3/8	97	R06X1.5CF	48	R15X1CF	48
GFS36/35L	12	PA392024	85	R06X1-316BA	52	R15X2	48
GFS36/38S	12	PRF102/100	38	R06X1.571	51	R15X2CF	48
GFS36/42L	12	PRF102/102	38	R06X1CF	48	R15X2ST52CF	50
GFS36/112G	16	PRF104/102	38	R06X2.25	48	R15X171	51
GFS36/114G	16	PRF104/104	38	R06X2.25CF	48	R15X271	51
GFS38/2G	16	PRF106/104	38	R06X2CF	48	R16X1.5	48
GFS38/112G	16	PRF106/106	38	R06X171	51	R16X1.5CF	48
GFS62/12G	16	PRF108/106	38	R08X1	48	R16X1.5ST52CF	50
GFS62/12S	13	PRF108/108	38	R08X1.5	48	R16X1.571	51
GFS62/14S	13	PRF110/108	38	R08X1.5CF	48	R16X2	48
GFS62/16S	13	PRF110/110	38	R08X1-316BA	52	R16X2	54
GFS62/38G	16	PRF112/110	38	R08X1.571	51	R16X2	55
GFS63/12G	16	PRF112/112	38	R08X1CF	48	R16X2.5	48
GFS63/16S	13	PRF402/402	38	R08X2	48	R16X2.5-316	52
GFS63/20S	13	PRF403/402	38	R08X2.5CF	48	R16X2.5CF	48
GFS63/25S	13	PRF403/403	38	R08X2CF	48	R16X2.5ST52CF	50
GFS63/30S	13	PRF404/403	38	R08X171	51	R16X2-316	52
GFS63/34G	16	PRF404/404	38	R10X1	48	R16X2-316	60
GFS63/38S	13	PRF405/404	38	R10X1.5	48	R16X2-316	61
GFS64/1G	16	PRF405/405	38	R10X1.5-316BA	52	R16X2.571	51
GFS64/20S	13	PRF406/405	38	R10X1.5CF	48	R16X2CF	48
GFS64/25S	13	PRF406/406	38	R10X1-316BA	52	R16X2CF	54
GFS64/30S	13	PRF408/406	38	R10X1.571	51	R16X2CF	55
GFS64/34G	16	PRF410/406	38	R10X1CF	48	R16X2ST52	50
GFS64/38S	13	PWDA-1/12	46	R10X2	48	R16X2ST52	56
GFS65/1G	16	PWDA-1/38	46	R10X2.5	48	R16X2ST52	57
GFS65/25S	13	PWDA-2/12	46	R10X2.5CF	48	R16X2ST52CF	50
GFS65/30S	13	PWDA-2/34	46	R10X2-316BA	52	R16X2ST52CF	56
GFS65/30S/12	13	PWDA-3/34	46	R10X2CF	48	R16X2ST52CF	57
GFS65/38S	13	PWDA-3/100	46	R10X2ST52CF	50	R16X3	48
GFS65/38S/12	13	PWDA-05/12	46	R10X3CF	48	R16X3CF	48
GFS65/114G	16	PWDA-05/38	46	R10X171	51	R16X271	51
GFS66/30S	13	PWDS-G1/LK55	45	R10X271	51	R16X271	58
GFS66/38S	13	PWDS-G12/LK30	45	R12X1	48	R16X271	59
GFS66/112G	16	PWDS-G12/LK35	45	R12X1.5	48	R16X371	51
GFS66/114G	16	PWDS-G12/LK40	45	R12X1.5	54	R18X1	48
GFS68/2G	16	PWDS-G34/LK40	45	R12X1.5	55	R18X1.5	48
GFS68/112G	16	PWDS-G34/LK55	45	R12X1.5-316BA	52	R18X1.5-316	52
GFSG32/12G	16	PWDS-G38/LK30	45	R12X1.5-316BA	60	R18X1.5CF	48
GFSG32/38G	16	PWDS-G38/LK35	45	R12X1.5-316BA	61	R18X1.5ST52CF	50
GFSG33/12G	16	R1/2X0.035TP316/L	53	R12X1.5CF	48	R18X1.571	51
GFSG33/34G	16	R1/2X0.049TP316/L	53	R12X1.5CF	54	R18X1CF	48
GFSG34/1G	16	R1/2X0.065TP316/L	53	R12X1.5CF	55	R18X2	48
GFSG34/34G	16	R1/2X0.083TP316/L	53	R12X1.5ST52CF	50	R18X2	54
GFSG35/1G	16	R1/4X0.035TP316/L	53	R12X1.5ST52CF	56	R18X2	55
GFSG35/114G	16	R1/4X0.049TP316/L	53	R12X1.5ST52CF	57	R18X2.5	48
GFSG36/112G	16	R1/4X0.065TP316/L	53	R12X1-316BA	52	R18X2.5CF	48
GFSG36/114G	16	R1/8X0.028TP316/L	53	R12X1.571	51	R18X2-316	52
GFSG38/2G	16	R1X0.065TP316/L	53	R12X1.571	58	R18X2-316	60
GFSG38/112G	16	R1X0.083TP316/L	53	R12X1.571	59	R18X2-316	61
GFSG62/12G	16	R1X0.095TP316/L	53	R12X1CF	48	R18X2CF	48
GFSG62/38G	16	R1X0.126TP316/L	53	R12X2	48	R18X2CF	54
GFSG63/12G	16	R3/4X0.049TP316/L	53	R12X2.5CF	48	R18X2CF	55
GFSG63/34G	16	R3/4X0.065TP316/L	53	R12X2-316BA	52	R18X2ST52CF	50
GFSG64/1G	16	R3/4X0.083TP316/L	53	R12X2CF	48	R18X2ST52CF	56
GFSG64/34G	16	R3/4X0.095TP316/L	53	R12X2ST52CF	50	R18X2ST52CF	57
GFSG65/1G	16	R3/4X0.109TP316/L	53	R12X3.5CF	48	R18X3CF	48
GFSG65/114G	16	R3/8X0.035TP316/L	53	R12X3CF	48	R18X271	51
GFSG66/112G	16	R3/8X0.049TP316/L	53	R12X171	51	R18X271	58
GFSG66/114G	16	R3/8X0.065TP316/L	53	R12X271	51	R18X271	59
GFSG68/2G	16	R3/16X0.035TP316/L	53	R14X1.5CF	48	R20X1.5CF	49
GFSG68/112G	16	R04X0.5	48	R14X1.571	51	R20X2	49
HSRS25	87	R04X0.5CF	48	R14X2	48	R20X2	54
HSRS25	88	R04X0.75CF	48	R14X2.5	48	R20X2	55
HSRS30	87	R04X1	48	R14X2.5CF	48	R20X2.5	49
HSRS30	88	R04X1-316BA	52	R14X2.571	51	R20X2.5	54
HSRS35	87	R04X1CF	48	R14X2CF	48	R20X2.5	55
HSRS35	88	R04X171	51	R14X3CF	48	R20X2.5-316	52
HSRS38	87	R5/8X0.049TP316/L	53	R14X271	51	R20X2.5-316	60
HSRS42	87	R5/8X0.065TP316/L	53	R15X1	48	R20X2.5-316	61
HSRS42	88	R05X1CF	48	R15X1.5	48	R20X2.5CF	49
HSRS50	87	R06X0.75CF	48	R15X1.5-316BA	52	R20X2.5CF	54

R20X2.5CF	55	R25X3ST52CF	56	R35X2.5	49	R42X2CF	49
R20X2.5ST52	56	R25X3ST52CF	57	R35X2.5CF	49	R42X2CF	54
R20X2.5ST52	57	R25X4	49	R35X2.571	51	R42X2CF	55
R20X2.5ST52CF	50	R25X4.5CF	49	R35X2CF	49	R42X3	49
R20X2.5ST52CF	56	R25X4CF	49	R35X3	49	R42X3	54
R20X2.5ST52CF	57	R25X4ST52CF	50	R35X3-316	52	R42X3	55
R20X2-316	52	R25X4ST52CF	56	R35X3CF	49	R42X3-316	52
R20X2-316	60	R25X4ST52CF	57	R35X3ST52CF	50	R42X3-316	60
R20X2-316	61	R25X271	51	R35X4CF	49	R42X3-316	61
R20X2.571	51	R25X371	51	R35X271	51	R42X3CF	49
R20X2.571	58	R25X371	58	R35X371	51	R42X3CF	54
R20X2.571	59	R25X371	59	R38X2.5-316	60	R42X3CF	55
R20X2CF	49	R26.67X2.11-316	62	R38X2.5-316	61	R42X3ST52CF	50
R20X2CF	54	R26.67X2.81-316	62	R38X2.5CF	49	R42X3ST52CF	56
R20X2CF	55	R26.67X3.91-316	62	R38X2.5CF	54	R42X3ST52CF	57
R20X2ST52	56	R26.67X5.56-316	62	R38X2.5CF	55	R42X4	49
R20X2ST52	57	R28X1.5	49	R38X2.571	51	R42X4	54
R20X2ST52CF	50	R28X1.5CF	49	R38X2.571	58	R42X4	55
R20X2ST52CF	56	R28X1.571	51	R38X2.571	59	R42X4CF	49
R20X2ST52CF	57	R28X2	49	R38X3	49	R42X4CF	54
R20X3	49	R28X2.5	49	R38X3	54	R42X4CF	55
R20X3.5CF	49	R28X2.5CF	49	R38X3	55	R42X4ST52CF	50
R20X3CF	49	R28X2-316	52	R38X3-316	52	R42X4ST52CF	56
R20X3ST52CF	50	R28X2.571	51	R38X3-316	60	R42X4ST52CF	57
R20X4CF	49	R28X2CF	49	R38X3-316	61	R42X5ST52CF	50
R20X271	51	R28X2ST52CF	50	R38X3CF	49	R42X5ST52CF	56
R20X271	58	R28X3	49	R38X3CF	54	R42X5ST52CF	57
R20X271	59	R28X3CF	49	R38X3CF	55	R42X271	51
R20X371	51	R28X271	51	R38X3ST52CF	50	R42X371	51
R21.34X2.11-316	62	R30X2.5	49	R38X3ST52CF	56	R42X371	58
R21.34X2.77-316	62	R30X2.5-316	52	R38X3ST52CF	57	R42X371	59
R21.34X3.73-316	62	R30X2.5CF	49	R38X4	49	R46X8ST52CF	56
R21.34X4.78-316	62	R30X2.571	51	R38X4	54	R46X8ST52CF	57
R22X1.5	49	R30X2CF	49	R38X4	55	R48.26X2.77-316-A999	62
R22X1.5CF	49	R30X3	49	R38X4-316	52	R48.26X3.68-316-A999	62
R22X1.5ST52CF	50	R30X3	54	R38X4-316	60	R48.26X5.08-316-A999	62
R22X1.571	51	R30X3	55	R38X4-316	61	R48.26X7.14-316-A999	62
R22X2	49	R30X3-316	52	R38X4CF	49	R50X3	54
R22X2.5	49	R30X3-316	60	R38X4CF	54	R50X3	55
R22X2.5CF	49	R30X3-316	61	R38X4CF	55	R50X3-316	60
R22X2-316	52	R30X3CF	49	R38X4ST52	50	R50X3-316	61
R22X2CF	49	R30X3CF	54	R38X4ST52	56	R50X3CF	54
R22X2ST52CF	50	R30X3CF	55	R38X4ST52	57	R50X3CF	55
R22X3CF	49	R30X3ST52	50	R38X4ST52CF	50	R50X3ST52CF	56
R22X271	51	R30X3ST52	56	R38X4ST52CF	56	R50X3ST52CF	57
R25X2	49	R30X3ST52	57	R38X4ST52CF	57	R50X5-316	60
R25X2.5	49	R30X3ST52CF	50	R38X5	49	R50X5-316	61
R25X2.5	54	R30X3ST52CF	56	R38X5	54	R50X5ST52	56
R25X2.5	55	R30X3ST52CF	57	R38X5	55	R50X5ST52	57
R25X2.5-316	52	R30X4	49	R38X5-316	52	R50X5ST52CF	56
R25X2.5-316	60	R30X4	54	R38X5-316	60	R50X5ST52CF	57
R25X2.5-316	61	R30X4	55	R38X5-316	61	R50X6	54
R25X2.5CF	49	R30X4-316	60	R38X5CF	49	R50X6	55
R25X2.5CF	54	R30X4-316	61	R38X5CF	54	R50X6-316	60
R25X2.5CF	55	R30X4CF	49	R38X5CF	55	R50X6-316	61
R25X2.5ST52CF	50	R30X4CF	54	R38X5ST52CF	50	R50X6ST52CF	56
R25X2.5ST52CF	56	R30X4CF	55	R38X5ST52CF	56	R50X6ST52CF	57
R25X2.5ST52CF	57	R30X4ST52CF	50	R38X5ST52CF	57	R50X8ST52CF	56
R25X2-316	52	R30X4ST52CF	56	R38X6-316	52	R50X8ST52CF	57
R25X2.571	51	R30X4ST52CF	57	R38X6CF	49	R56X8.5ST52	56
R25X2.571	58	R30X5	49	R38X6ST52CF	50	R56X8.5ST52	57
R25X2.571	59	R30X5CF	49	R38X6ST52CF	56	R56X8.5ST52CF	56
R25X2CF	49	R30X5ST52CF	50	R38X6ST52CF	57	R56X8.5ST52CF	57
R25X3	49	R30X5ST52CF	56	R38X7CF	49	R60.33X2.77-316-A999	62
R25X3	54	R30X5ST52CF	57	R38X471	51	R60.33X3.91-316-A999	62
R25X3	55	R30X371	51	R38X471	58	R60.33X5.54-316-A999	62
R25X3-316	52	R30X371	58	R38X471	59	R60.33X8.74-316-A999	62
R25X3-316	60	R30X371	59	R39X7.5ST52CF	56	R60X3	54
R25X3-316	61	R30X471	51	R39X7.5ST52CF	57	R60X3	55
R25X3CF	49	R30X471	58	R42.16X2.77-316-A999	62	R60X3-316	60
R25X3CF	54	R30X471	59	R42.16X3.56-316-A999	62	R60X3-316	61
R25X3CF	55	R33.40X2.77-316-A999	62	R42.16X4.85-316-A999	62	R60X3CF	54
R25X3ST52	50	R33.40X3.38-316-A999	62	R42.16X6.35-316-A999	62	R60X3CF	55
R25X3ST52	56	R33.40X4.55-316-A999	62	R42X2	49	R60X3ST52CF	56
R25X3ST52	57	R33.40X6.35-316-A999	62	R42X2	54	R60X3ST52CF	57
R25X3ST52CF	50	R35X2	49	R42X2	55	R60X5-316	60

R60X5-316	61	R114.30X13.49-316-A999	62	RB38X3CF	63	WFS63/34G	17
R60X5ST52CF	56	R115X4	54	RB38X4	63	WFS64/1G	17
R60X5ST52CF	57	R115X4	55	RB38X4CF	63	WFS64/20S	15
R60X6-316	60	R115X15ST52	56	RB38X5	63	WFS64/25S	15
R60X6-316	61	R115X15ST52	57	RB38X5CF	63	WFS64/30S	15
R60X6ST52	56	R120X20ST52	56	RB38X471	63	WFS64/34G	17
R60X6ST52	57	R120X20ST52	57	RB42X2	63	WFS64/114G	17
R60X6ST52CF	56	R130X15ST52	56	RB42X2CF	63	WFS65/1G	17
R60X6ST52CF	57	R130X15ST52	57	RB42X3	63	WFS65/25S	15
R60X8ST52CF	56	R140X4.5	54	RB42X3CF	63	WFS65/25S/12	15
R60X8ST52CF	57	R140X4.5	55	RB42X271	63	WFS65/30S	15
R65X8	54	R141.30X6.55-316-A999	62	RB50X6	63	WFS65/30S/12	15
R65X8	55	R141.30X9.53-316-A999	62	RB65X8	63	WFS65/38S	15
R65X8ST52CF	56	R141.30X15.88-316-A999	62	SCV-1700	132	WFS65/38S/12	15
R65X8ST52CF	57	R150X15ST52	56	SCV-1701	132	WFS65/114G	17
R66X8.5-316	60	R150X15ST52	57	SCV-1702	132	WFS66/30S	15
R66X8.5-316	61	R165X5	54	UC-2000	133	WFS66/38S	15
R66X8.5ST52	56	R165X5	55	UC-2001	133	WFS66/112G	17
R66X8.5ST52	57	R168.28X3.40-316	62	UC-2002	133	WFS66/114G	17
R66X8.5ST52CF	56	R168.28X7.11-316-A999	62	UC-2301	128	WFS66/114G	17
R66X8.5ST52CF	57	R168.28X18.26-316-A999	62	UC-2302	128	WFS66/114G	17
R73.03X3.05-316-A999	62	R190X20ST52	56	UC-2303	128	WFS66/114G	17
R73.03X5.16-316-A999	62	R190X20ST52	57	UC-2304	128	WFS66/114G	17
R73.03X7.01-316-A999	62	R219.08X8.18-316	62	UC-2305	128	WFS66/114G	17
R73.03X9.53-316-A999	62	R219.08X23.01-316-A999	62	UC-2311	128	WFS66/114G	17
R73X7-316	60	R220X6	54	UC-2312	128	WFS66/114G	17
R73X7-316	61	R220X6	55	UC-2313	128	WFS66/114G	17
R73X7ST52	56	R250X25ST52	56	UC-2314	128	WFS66/114G	17
R73X7ST52	57	R250X25ST52	57	UC-2315	128	WFS66/114G	17
R73X7ST52CF	56	R273X6	54	WFS32/12G	17	WFS66/112G	17
R73X7ST52CF	57	R273X6	55	WFS32/12S	14	WFS66/114G	17
R75X3	54	RB16X2	63	WFS32/15L	14	WFS66/114G	17
R75X3	55	RB16X2CF	63	WFS32/16S	14	WFS66/114G	17
R75X3-316	60	RB16X271	63	WFS32/18L	14	WFS66/114G	17
R75X3-316	61	RB18X1.5	63	WFS32/38G	17	WFS66/114G	17
R75X3CF	54	RB18X1.5CF	63	WFS33/1G	17	WFS66/114G	17
R75X3CF	55	RB18X1.571	63	WFS33/12G	17	WFS66/114G	17
R75X5-316	60	RB20X2	63	WFS33/16S	14	WFS66/114G	17
R75X5-316	61	RB20X2.5	63	WFS33/18L	14	WFS66/114G	17
R75X5ST52	56	RB20X2.5CF	63	WFS33/20S	14	WFS66/114G	17
R75X5ST52	57	RB20X2.571	63	WFS33/22L	14	WFS66/114G	17
R75X5ST52CF	56	RB20X2CF	63	WFS33/25S	14	WFS66/114G	17
R75X5ST52CF	57	RB22X1.5	63	WFS33/34G	17	WFS66/114G	17
R75X12.5ST52	56	RB22X1.5CF	63	WFS34/1G	17	WFS66/114G	17
R75X12.5ST52	57	RB22X2	63	WFS34/20S	14	WFS66/114G	17
R80X3ST52	56	RB22X2CF	63	WFS34/22L	14	WFS66/114G	17
R80X3ST52	57	RB22X271	63	WFS34/25S	14	WFS66/114G	17
R80X8ST52	56	RB25X2	63	WFS34/28L	14	WFS66/114G	17
R80X8ST52	57	RB25X2.5	63	WFS34/30S	14	WFS66/114G	17
R80X10-316	60	RB25X2.5CF	63	WFS34/34G	17	WFS66/114G	17
R80X10-316	61	RB25X2.571	63	WFS34/114G	17	WFS66/114G	17
R80X10ST52	56	RB25X2CF	63	WFS35/1G	17	WFS66/114G	17
R80X10ST52	57	RB25X3	63	WFS35/25S	14	WFS66/114G	17
R88.90X3.05-316	62	RB25X3CF	63	WFS35/25S/10	14	WFS66/114G	17
R88.90X5.49-316-A999	62	RB28X1.5	63	WFS35/30S	14	WFS66/114G	17
R88.90X7.62-316-A999	62	RB28X1.5CF	63	WFS35/30S/10	14	WFS66/114G	17
R88.90X11.13-316-A999	62	RB28X2	63	WFS35/35L	14	WFS66/114G	17
R88X14ST52	56	RB28X2CF	63	WFS35/35L/10	14	WFS66/114G	17
R88X14ST52	57	RB28X3	63	WFS35/38S	14	WFS66/114G	17
R90X3.5	54	RB28X3CF	63	WFS35/38S/10	14	WFS66/114G	17
R90X3.5	55	RB28X271	63	WFS35/114G	17	WFS66/114G	17
R90X3.5CF	54	RB30X2.5	63	WFS36/35L	14	WFS66/114G	17
R90X3.5CF	55	RB30X2.5CF	63	WFS36/38S	14	WFS66/114G	17
R90X3.5ST52	56	RB30X3	63	WFS36/42L	14	WFS66/114G	17
R90X3.5ST52	57	RB30X3CF	63	WFS36/112G	17	WFS66/114G	17
R90X5ST52	56	RB30X4	63	WFS36/114G	17	WFS66/114G	17
R90X5ST52	57	RB30X4CF	63	WFS62/12G	17	WFS66/114G	17
R90X9ST52	56	RB30X371	63	WFS62/12S	15	WFS66/114G	17
R90X9ST52	57	RB35X2	63	WFS62/14S	15	WFS66/114G	17
R97X12ST52	56	RB35X2CF	63	WFS62/16S	15	WFS66/114G	17
R97X12ST52	57	RB35X3	63	WFS62/34G	17	WFS66/114G	17
R100X4	54	RB35X3CF	63	WFS63/1G	17	WFS66/114G	17
R100X4	55	RB35X271	63	WFS63/12G	17	WFS66/114G	17
R114.30X3.05-316	62	RB38X2.5	63	WFS63/16S	15	WFS66/114G	17
R114.30X6.02-316-A999	62	RB38X2.5CF	63	WFS63/20S	15	WFS66/114G	17
R114.30X8.56-316-A999	62	RB38X3	63	WFS63/25S	15	WFS66/114G	17

Notes

